



Operator's Manual
and Parts List
PRO-MAX 36

Rotary Finishing Mower
Serial No. 1336228 and up



PROGRESSIVE TURF EQUIPMENT INC.
137 WEST WILLIAM STREET
SEAFORTH, ONTARIO
CANADA N0K 1W0

PHONE: 519-527-1080
TOLL FREE: 800 668-8873
ISSUE DATE: March 2014

SERIAL # _____
WEB: www.progressiveturfequip.com

P.N.120515

 **DANGER!**

Si No Lee Ingles, Pida Ayuda a Alguien Que Se Lo Lea
Para Que le Traduzca Las Medidas de Seguridad

TABLE OF CONTENTS

INTRODUCTION	
TO THE OWNER	3
GENERAL INFORMATION	4
SPECIFICATIONS	5
WARRANTY	6
SAFETY RULES	
SAFETY ALERT SYMBOL	7
HAZARD SERIOUSNESS LEVEL	7
GENERAL SAFETY PRECAUTIONS	8
POWER UNIT SAFETY	8
OPERATING EQUIPMENT SAFELY	9
MAINTENANCE SAFETY PRECAUTIONS	10
WELDING AND GRINDING WORK PRECAUTIONS	11
WORKING ON PAINTED SURFACES	11
SAFETY AND MAINTENANCE DECAL LOCATIONS	12
PM36 DECALS LISTING	13
MOWER SETUP FOR OPERATION	
ADJUSTABLE HITCH ADAPTOR	15
TRACTOR DRAWBAR	16
PTO BEARING BRACKET SETUP	16
TD92 HOOKUP TO Pro-Max 36	18
TD92 CONNECTING FRAME	19
TD92 CONNECTING LINK	20
CONNECTING THE INPUT PTO SHAFT	21
CHECKING PTO LENGTH DURING TURNS	21
OPERATION OF THE MOWER	
DAILY CHECK LIST	22
PROPER TORQUE OF FASTENERS	23
CUTTING HEIGHT ADJUSTMENT	24
LOWERING THE WING DECKS	24
DECK POSITION BUSHING	25
TIRES	25
PTO SHAFTS	26
LUBRICATION	26
GREASE COMPATIBILITY	27
TRANSPORTING MOWER	
SAFETY CHAINS	28
DECK LOCK PINS	29
WING LOCK PINS	29
TRANSPORT PRO-MAX 36 ONLY	30
MAINTENANCE	
MOWER BLADE SERVICING	31
BLADE REMOVAL & INSTALLATION	32
BLADE SHARPENING	32
SPINDLE INSPECTION	33
SPINDLE ASSEMBLY AND REMOVAL	33
SPINDLE ASSEMBLY INSTALLATION	33
ASSEMBLY OF SPINDLES	34
“V” BELT ADJUSTMENT	35
“V” BELT TENSION	35
HYDRAULICS	36
TROUBLE SHOOTING	37

TO THE OWNER:

Before you operate this mower, study this manual carefully. It has been prepared to help you do a better and safer job of maintaining your mower.

Use only genuine Progressive Turf Equipment Inc. replacement parts. Substitute parts will void the warranty and may not meet the standards required for safe and satisfactory operation of this equipment.

ATTENTION! Your personal safety is involved. Be sure to observe and follow these instructions.



CAUTION! A reminder about safety practices, or directs attention to unsafe practices which could result in personal injury if proper precautions are not taken.



WARNING! A hazard exists which can result in injury or death if proper precautions are not taken.



DANGER! An extreme intrinsic hazard exists, which would result in a high probability of death or injury, if proper precautions are not taken.

GENERAL INFORMATION:

The main purpose of this manual is to assist the operator in maintaining and operating Progressive Turf Equipment mowers. Read it carefully. It provides information and instructions that will help you achieve years of dependable performance. Some information may be general in nature due to unknown and varying conditions.

Throughout this manual, references are made to right and left directions. These are determined by standing at the rear of the equipment and facing the direction of forward travel. Blade rotation is counter-clockwise as viewed from the top of the mower.

For quick reference, record the following information:

Model: PRO-MAX 36

Date Purchased: _____

Serial Number: _____

For additional information, assistance during assembly or operation of this mower contact the dealer you contacted the machine from, or call Progressive Turf Equipment Inc.

PHONE (519)527-1080 1-800-668-8873 FAX 1-519-527-2275

Email: info@progressiveturfequip.com

NOTE: The Warranty Registration form must be completed and returned to Progressive Turf Equipment Inc. to validate the warranty.

SPECIFICATIONS

DESCRIPTION	Pro-Max 36
Cutting Width	36'
Cutting Height	3/4" to 5"
Recommended PTO HP	80 to 110 (or 64% more than what is currently used)
Hydraulics	Requires 2 double acting outlets. One with float position.
Transport Width	13'
Height (folded)	13'
Length	Pro-Max 36 only 13'2". Complete system with 22' mower 29'8".
Ground Clearance	8"
Deck Flexibility	25 degrees up 15 degrees down
Number of Tires	Pro-Max 36 - 2 road wheels, 8 deck wheels. Total system – 4 road wheels, 18 deck wheels
Mowing Capacity MPH	2 8.8 acres/hr 4 17.5 acres/hr 6 26 acres/hr 7.5 32.8 acres/hr Assumes no stops or overlap
Weight	4600 lbs.
Tongue Weight	1400 lbs. in transport position
Tongue Weight	700 lbs. in mowing position
Paint Finish	Electrostatically applied paint with oven baked finish
Deck	Note: see TD-92 specifications for mower deck information
Frame	Hollow structural steel tubing with supports at high stress areas to achieve maximum strength.
Axles	Two specially designed castors with 6000 lb. rating for transport wheels
Wheels	6 bolt with 6" bolt circle
Tires	2 of P275/60SR 15" automotive style radials
Cylinders	Wing lift – 2 of 3.5" by 24"
Screw Jack	5000 lb. top wind jack for easy hook-up
Main Gearbox	4 shaft gearbox with 1 3/8" – 6 spline shafts
PTO Shafts	Telescoping, agricultural PTO driveshafts with proper safety shields 1-3/8"-6 spline quick disconnect yoke on both ends with ring lock collars
Input PTO	Category # 6 H.D.
Deck PTO	Category # 3 H.D.

WARRANTY POLICY

Progressive Turf Equipment Inc. warrants each new product to be free of defects in material and workmanship to the original purchaser. Warranty will be applicable, from the original date of purchase of the following new, unused current models:

ProFlex 120, ProFlex 120R, TD65-2, TD65, TD92, Pro-Max 36 TDR-15, TDR-12, TDR-22, SDR-65, SDR-90

Basic Mower: 24 months

Gear Boxes: 36 months

To validate warranty, the Delivery and Warranty Registration form must be completely filled out & mailed to Progressive Turf Equipment Inc.

This warranty will not cover any components which, in the opinion of the company, have been subjected to negligent use, alteration, and accident, damage due to lack of maintenance or use of wrong lubricants, or if parts supplied by others have been used in repairs of any product manufactured by Progressive Turf Equipment Inc. Items such as blades, belts, tires, wheels and batteries are considered consumable wear items and are excluded from Progressive Turf Equipment Inc.'s warranty coverage. Warranty coverage on these items is limited to what is provided by the OEM of the applicable part, if any.

Our obligation, in the event that any Progressive Turf Equipment Inc. product warranted, shall become defective or fail, will be limited to repairing or replacing free of charge, or provide labour and materials for the repair of, any defective part, subject to company approval. All defective parts must be retained for 60 days after applying for warranty consideration. This warranty will not provide for service calls to customer location or for transportation of equipment to dealer location if such servicing is required.

The sole liability of Progressive Turf Equipment Inc. under this warranty or any implied warranty, shall be limited as set forth herein. The customer agrees that Progressive Turf shall not in any event be obligated to reimburse, or pay the customer for any expense, loss or any direct, incidental or consequential damages to any person or property for any reason or caused by reason of Progressive Turf Equipment Inc., negligence, or otherwise in connection with the sale, delivery, installation, training or use of the equipment. The customer shall indemnify and hold Progressive Turf Equipment Inc. harmless against all such liability. PROGRESSIVE TURF EQUIPMENT INC. DISCLAIMS ANY EXPRESS (EXCEPT AS SET FORTH HEREIN) AND IMPLIED WARRANTIES WITH RESPECT TO THE GOODS INCLUDING, BUT NOT LIMITED TO, MERCHANTABILITY AND FITNESS FOR A PARTICULAR PURPOSE AND MAKES NO WARRANTY AS TO THE DESIGN, CAPABILITY, CAPACITY, OR SUITABILITY FOR USE OF THE GOODS.

Progressive Turf Equipment Inc. reserves the right to make improvements to the design or changes to the specifications at any time without prior notice or any obligation or duty to inform current owners or modify units previously sold.

This warranty is not subject to change or modification by anyone, including dealers, and no one is authorized to make any representation on behalf of Progressive Turf Equipment Inc.

KEEP FOR YOUR RECORDS: Purchaser should fill in the blanks below for his reference when buying repair parts and/or for proper machine identification when applying for warranty.

Model _____ Serial Number _____

Date Purchased _____ Dealer _____

Read your Operator's Manual

This warranty coverage supersedes all written warranties, effective November 1, 2012.

SAFETY RULES

All rotary mowers are potentially dangerous machines; this mower has been designed to minimize the safety risks to the operator, bystanders and property. This section of the Operator's Manual details a number of safety rules pertaining to the operation and maintenance of Progressive Turf Equipment mowers. In order to minimize risks and promote safety at all times, these rules must always be followed and obeyed.

Further safety rules and warning texts are given within the respective sections of this manual.

IMPORTANT!

When it comes to safety, nothing will ever replace a careful operator.

It is imperative that the operator reads and understands all the safety information in this manual before proceeding. Failure to follow the instructions or heed the warnings could result in injury or death.

Proper care is your responsibility.

The manufacturer cannot anticipate every possible circumstance that might involve a hazard. The hazard alerts in this publication and on the product, are therefore not all inclusive. If a tool, procedure, work method, or operating technique not specifically recommended by the manufacturer is used, it is your responsibility to ensure that it is safe for you and others. You should also ensure the machine will not be damaged or made unsafe by the operation, maintenance, or repair procedures you choose. Modifications or adaptations to the machine are not allowed.

Various jurisdictions have specific requirements for work zone safety. Know and adhere to your local requirements. Treat the instructions in this manual as minimum requirements for safe operation.

SAFETY ALERT SYMBOL

This symbol appears at various points in the manual together with a signal word and warning text. **It means – Be alert! Your safety is involved.** This

symbol is used throughout the manual to call attention to areas in which carelessness or failure to follow specific procedures may result in personal injury or component damage / malfunction or both.



HAZARD SERIOUSNESS LEVEL

The following signal words are found throughout the manual together with the safety alert symbol to indicate the seriousness level of identified hazards. Their selection is based on the consequence of human interaction with a hazard.

DANGER! –Hazards or unsafe practices which WILL result in severe personal injury or death.



WARNING! – Hazards or unsafe practices that COULD result in severe personal or death.



CAUTION! – Hazards or unsafe practices that COULD result in minor personal injury or product or property damage.



GENERAL SAFETY PRECAUTIONS

WARNING!

- The operator of this machine must have sufficient knowledge and instructions in the care and operation of this mower and the power unit being used before he / she uses the machine. Do not allow unauthorized persons or children to operate the machine. Do not allow riders on the machine.
- It is the obligation of the operator to make sure that all guards and shields are in place on the machine. Safety decals must be in place and be readable – accidents may otherwise occur. Contact your dealer or the manufacturer for replacement manuals or decals.
- Never use a machine that does not have an operator’s manual available. Learn and understand the safety signs and symbols on the machine and the operator instructions before you begin to use the machine.
- Wear personal protective equipment. Know and use the protective equipment that is to be worn when operating or servicing the machine. Hard hats, protective glasses and face shields, protective shoes, gloves, reflector type vests, and ear protection are types of equipment that may be required. Prolonged exposure to loud noise can cause hearing damage.

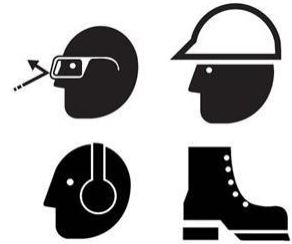

- Never operate a mower while under the influence of drugs or alcohol. These make reflexes slow and put you and others in grave danger. Always make sure you have full concentration while mowing.
- Adhere strictly to all regulations at the worksite pertaining to the operation of this equipment.
- Always disengage power takeoff (PTO) when transporting or traveling between work sites.
- Be prepared for emergencies. Have a first aid kit, fire extinguisher and emergency contact information available at the work site.

POWER UNIT SAFETY

WARNING!

- Operator must have sufficient knowledge in the care and operation of the power unit (tractor) before connecting power unit to mower.

- Power unit must be equipped with ROPS and seat belt. Foldable ROPS must be secured in the upright position. Follow recommendations of power unit manufacturer. Seat belt must be worn at all times.
- Power unit must be equipped with a 1-3/8" 6 spline 540 RPM PTO connection. Never use PTO adapters to connect implements. Never connect mower driveline to 1000 RPM PTO.

OPERATING EQUIPMENT SAFELY

WARNING!

- Never allow persons to stand between power unit and mower while backing power unit up to hitch the mower.
- Before hitching mower to power unit, place transmission in neutral, set park brake, and turn engine off. Remove the ignition key.
- Make sure locking collar on PTO shaft is properly locked. If the PTO shaft comes off during operation, personal injury or equipment damage could result.
- Always install safety chains properly when hitching mower to power unit.
- Tall grass can hide obstacles. Carefully walk the entire area to be mowed beforehand. Look for debris, rocks, tree limbs etc. that will damage or be thrown by the mower blades. Identify objects that cannot be removed. Set mower cutting height to avoid contact.
- Ensure that no bystanders are within 25 ft of mower when wing transport locks are released.
- Keep all bystanders well away from the machine when it is operating. Always maintain a safe operating distance of 300 ft from personnel, other equipment, or vehicles.
- Never operate the mower with deflectors or guards removed. Mower blades can cause small objects and debris to be thrown from under the mower deck at high speeds, up to 300 ft away. Objects ejected by the mower blades can cause severe injury.
- Never tamper with safety devices or operate the mower with them removed. Check proper operation regularly.
- Always disengage PTO, turn power unit off and remove key before dismounting, for any reason.
- Never place hands or feet under mower deck when the mower is operating or power unit engine is running.
- Disengage the PTO when crossing gravel areas or roadways.
- Disengage the PTO and turn power unit off upon striking any object. Inspect mower and repair any damage before continuing.

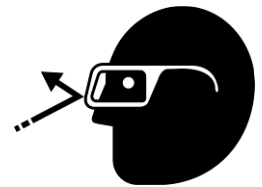

- If the equipment should start to vibrate abnormally during operation, stop the mower, shut down power unit, and immediately check for the cause. Excess vibration is generally an indication of a problem. Replace bent or damaged parts, do not attempt to straighten a bent blade.
- Use extreme care when operating on uneven terrain.
- Reduce speed when operating on slopes during wet conditions, especially when making sharp turns.
- Do not use the mower in limited visibility (e.g. at dusk, in fog, heavy rain etc.). Mow only in daylight or good artificial light.
- Disengage PTO and ensure blades are completely stopped before raising wings.
- Ensure transport locks are securely engaged before transporting mower with wings in raised position.
- Clean reflectors, Slow Moving Vehicle sign and lights before transporting. Use power unit hazard lights.
- Before disconnecting from power unit, always lower equipment to the ground, place controls in neutral, set park brake, turn engine off, and wait for all moving parts to stop. Relieve hydraulic pressure per power unit manufacturer's instructions.
- Ensure mower tongue jack is securely fastened to mower frame with supplied pin before removing hitch draw pin.

MAINTENANCE SAFETY PRECAUTIONS

WARNING!

- Never make adjustments or repairs with the engine running. Always disengage PTO, turn engine off, lower wings to cutting position and relieve hydraulic pressure before performing any maintenance.
- Observe and perform proper lock-out procedures for power unit if attached to mower during service.
- Keep nuts and bolts tight and properly torqued, especially blade attachment bolts. Check that all cotter pins are properly installed. Keep equipment in good condition.
- Keep mower free of grass, leaves, or other debris build-up.
- Never work on raised mower decks without safety locks in place.
- Periodically check condition of safety devices, guards, and deflectors. Replace only with manufacturer's recommended parts.
- Inspect and replace damaged blades. Use only original OEM parts. Blades can fail from poor maintenance practices.
- Handle mower blades carefully. They are sharp and can cut unprotected skin. Use caution and wear gloves when handling them.
- Check to make sure hydraulic hoses are not worn or damaged, and are routed to avoid chafing.



- Immediately replace any hydraulic hose that shows signs of swelling, wear, leaks or damage so it does not burst.
- Do not use your hand to check for hydraulic oil leaks. Use a piece of cardboard instead. Hydraulic fluid escaping under pressure can penetrate the skin causing serious injury. If skin penetration occurs, seek medical attention immediately. Relieve all pressure before disconnecting hoses.
- Do not bend or strike hydraulic lines, tubes or hoses, or reinstall them in a bent or damaged condition.
- Inspect tires daily for wear or damage. Check tire pressures weekly with an accurate pressure gauge. Do not inflate tires beyond 35 psi.
- Mounting and dismounting tires from rims can be dangerous and should be performed by trained personnel using correct tools, equipment and procedures.

WELDING AND GRINDING WORK PRECAUTIONS

IMPORTANT! A fire extinguisher should be easily accessible during all welding work.

- Welding repairs are to be performed by a trained welder with proper service instructions. Know the material to be welded and select the correct welding procedure and materials (electrodes, rods, wire) that will provide a weld metal strength equivalent to the parent material.
- Move the machine to a clean, safe area before welding, grinding or using a cutting torch on it. This type of work should only be done in a clean area and not in places that contain combustible liquids, such as fuel tanks, hydraulic pipes or similar.
- Connect arc welder ground as close as possible to work area.
- Work with extra care when welding, grinding or torch cutting near flammable objects.

WORKING ON PAINTED SURFACES

Heated paint gives off poisonous gases. Therefore, paint must be removed from an area with a radius of at least 4 in (10 cm) before carrying out welding, grinding, or gas cutting. In addition to the health hazard, the weld will be of inferior quality and strength if the paint is not removed.

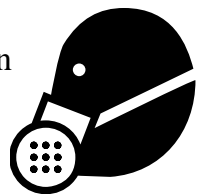

Methods and precautionary measures when removing paint:

- Blasting – use respiratory protective equipment and protective goggles.
- Paint remover or other chemicals – use a portable air extractor, respiratory protective equipment, and protective gloves.
- Grinding – use a portable air extractor, respiratory protective equipment, and protective gloves and goggles.

SAFETY & MAINTENANCE DECAL LOCATIONS

ITEM NO.	DESCRIPTION	QTY.	ITEM NO.	DESCRIPTION	QTY
1	CAUTION – READ MANUAL	1	9	CAUTION – PM36 TO TRACTOR	1
2	CAUTION – TURNING	1	10	GREASING SCHEDULE	1
3	CAUTION – REPLACE SHIELDS	9	11	MOWER MODEL	2
4	COMPANY NAME	1	12	NOTICE – PM HITCH SETUP	1
5	DANGER – BLADE HAZARD	4	13	INDICATOR – INPUT PTO	1
6	WARNING – OEM PARTS	2	14	DECK SIDE DECAL	2
7	CAUTION – DISENGAGE PTO	1	15	DANGER – OUTER TUBE	3
8	IMPORTANT GREASING	1	16	DANGER – OUTER SHIELD	3

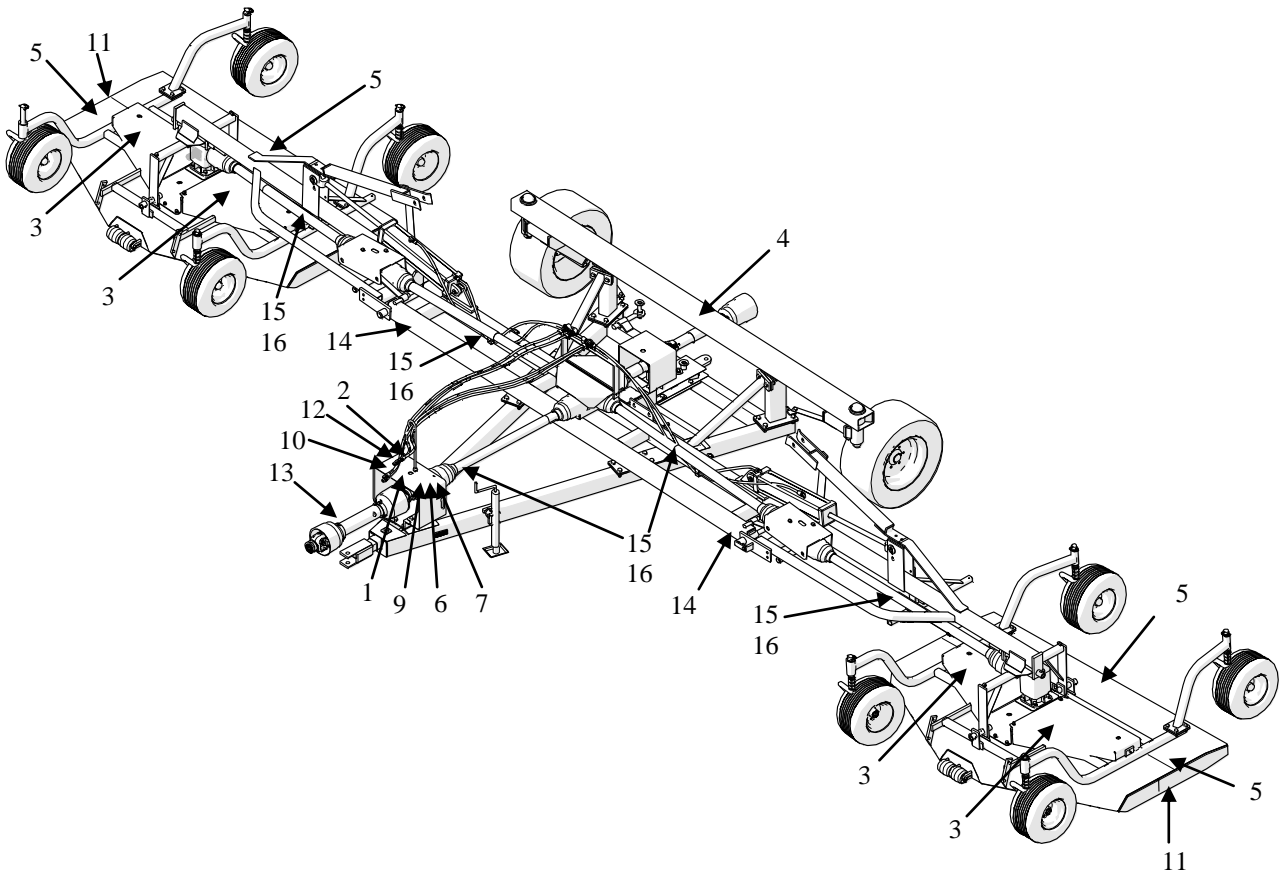

PM36 DECAL LISTING

If decals become faded, damaged or lost, replace immediately. Order according to corresponding Part # below. Complete decal kits are also available.

PM36 Decal Kit – 209106

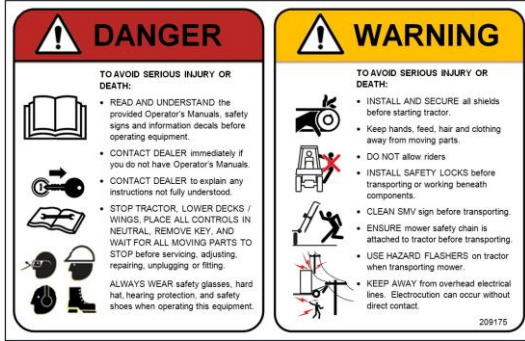

ITEM 1
(209175)

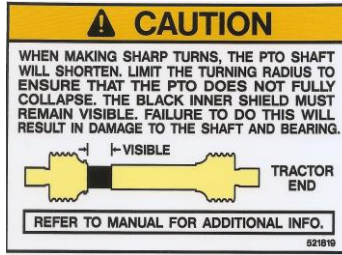

ITEM 2
(521819)



ITEM 3
(209113)



ITEM 4
(521817)



ITEM 5
(209173)



ITEM 6
(209115)



ITEM 7
(521820)



ITEM 8
(209114)

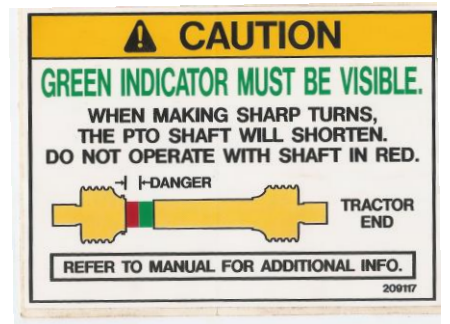

ITEM 9
(209117)

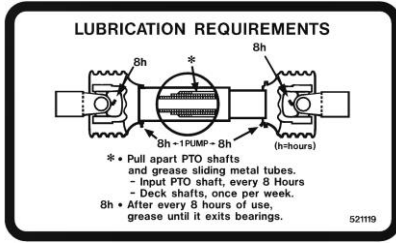

ITEM 10
(521119)

PROGRESSIVE PRO-MAX 36

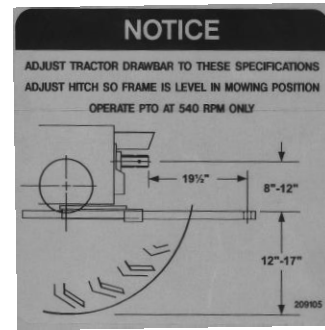

ITEM 12
(209105)



ITEM 13
(209118)



ITEM 14
(209112)



ITEM 15
(521451)

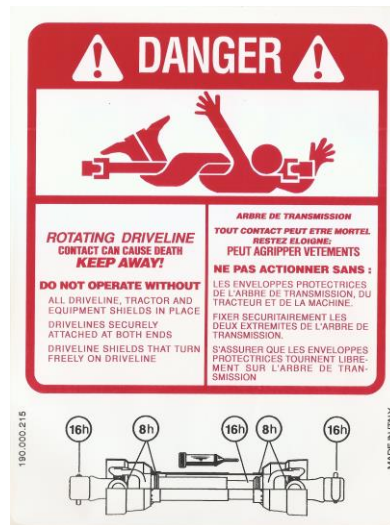

ITEM 16
(521455)



GREASE POINT DECAL
(521014)

MOWER SETUP FOR OPERATION:

HITCHING TO TRACTOR:

Before hitching the mower to the tractor, a number of conditions must be checked. Having the proper hitching dimensions for the tractor drawbar and the PTO will ensure long and trouble free hours of operation with this PTO driven mower. Incorrect setup will damage the driveline components prematurely.

The following decal is mounted to the machine:

Adjustable Hitch and PTO Shaft:

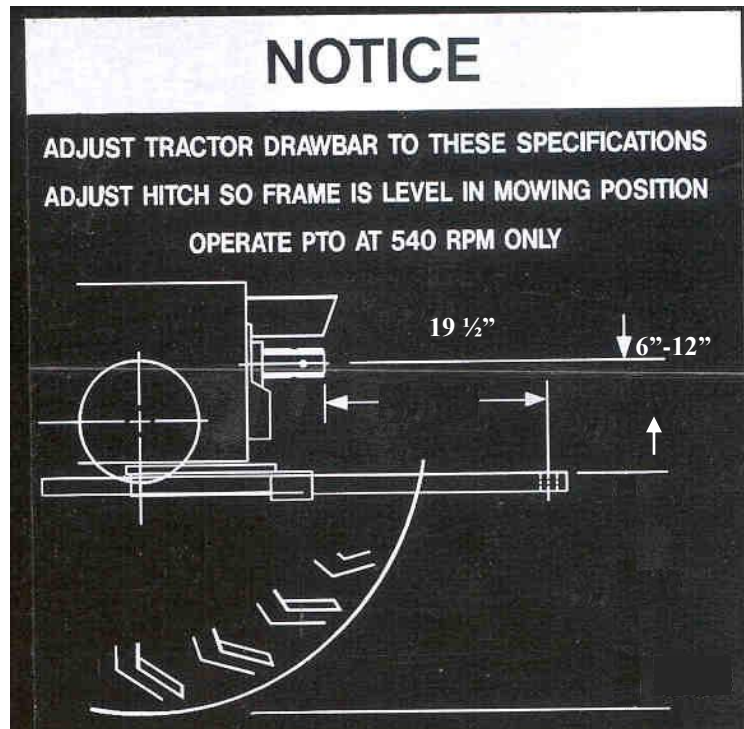

The Pro-Max 36 is equipped with an adjustable hitch plate for mounting on the tractor drawbar to ensure the correct distance between the end of the tractor PTO stub and the end of the Pro-Max 36 PTO stub. This distance should be 39". The drawpin of the mower should be exactly in the center of the two PTO shaft ends for smooth operation and long life for all driveline components. This set-up allows equal turning angles for the front and rear U-joints to avoid vibration while negotiating turns during the mowing process.

Use the following steps to ensure proper hook up.

Tractor Drawbar:

1. Raise or remove the safety guard around the tractor PTO shaft.
2. Using a straight edge, measure the distance from the end of the PTO shaft to the back edge of the drawpin hole. This distance should be 20”.

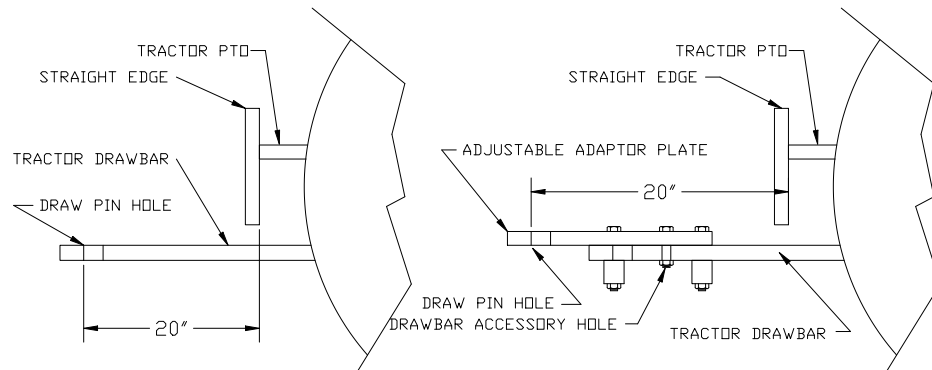

3. If this distance is not correct, check to see if the tractor drawbar is adjustable, and if there is a mounting hole that gives this dimension, adjust it so the distance is 20”.
4. If the drawbar cannot be set correctly on the tractor, use the adjustable tractor hitch unit supplied with the mower.
5. Mount the adaptor plate to the top of the drawbar as shown in the sketch.
6. Adjust the adaptor plate until the 20” dimension is set between the end of the tractor PTO and the back edge of the drawpin hole.
7. Snug up the 4 mounting bolts and mount the input PTO shaft.

PTO BEARING MOUNTING BRACKET SETUP:

It is important that the PTO shaft be in a straight line between the tractor PTO and the gearbox. This will ensure a long life and smooth operation of the driveline components.

8. When the mower is connected to the tractor, the mower hitch frame (A) should be as close to level with the ground as possible.

- To ensure proper life of the PTO shaft, the driveline from the mower gearbox (D) to the PTO shaft (E) on the tractor should be in a straight line.

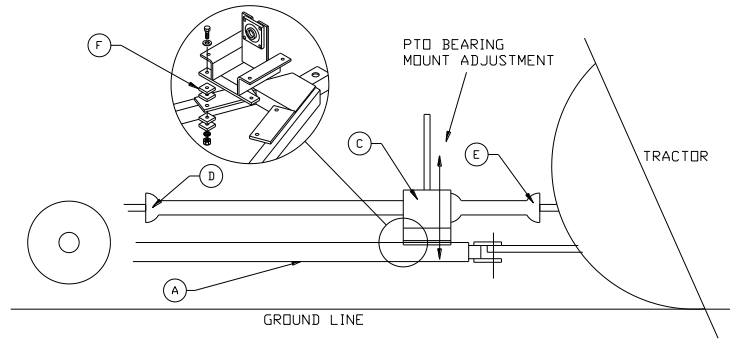

- Spacers (F) are provided under the bearing mounting bracket (C) to allow adjustment up or down. Each spacer is $\frac{1}{2}$ " high. Sixteen are provided, for a 2" total adjustment, four on each corner. Adjust spacers until the driveline is straight.
- For a final check, if everything is correct, the driveline will be straight and the grease zerker will be visible on the input shaft, when the shield grease holes are lined up.
- To complete the mounting of the adaptor plate, with a marking pen or scribe, mark the location of the accessory mounting hole in the tractor drawbar, on the adaptor plate. See sketch on Page 12.
- Remove the adaptor plate and drill the hole to match the accessory hole on the tractor drawbar.
- Re-mount the adaptor plate to the tractor and securely tighten all 5 bolts.



Proper setup will allow you to see the grease zerker on PTO shaft.

TD92 – HOOK UP TO Pro-Max 36:



1. With the transport wheel locked on the Pro-Max 36, back up to within 12” of the TD92 mower.
2. Remove the sliding drawbar lock pin and slide the drawbar out and connect to TD92.
3. Replace the sliding drawbar lock pin in bushing.
4. With TD92 frame still on the jack, back the unit up slowly and lock pin will fall into place. Replace the hair pin.
5. Connect the PTO shaft, hydraulics and deck lock release rope for the TD92 mower.



Drawbar
Lock Pin

TD92 CONNECTING FRAME:

A connecting frame is provided with the Pro-Max 36, that mounts to the TD92 mower, and is used to connect the two mowers together. The connecting link will mount to this, allowing the two mowers to be set up parallel with each other for proper cutting.

Mount the connecting frame (1) to the hitch frame (10) of the TD92 mower with the four 1/2" x 3 1/2" bolts. Tighten securely.

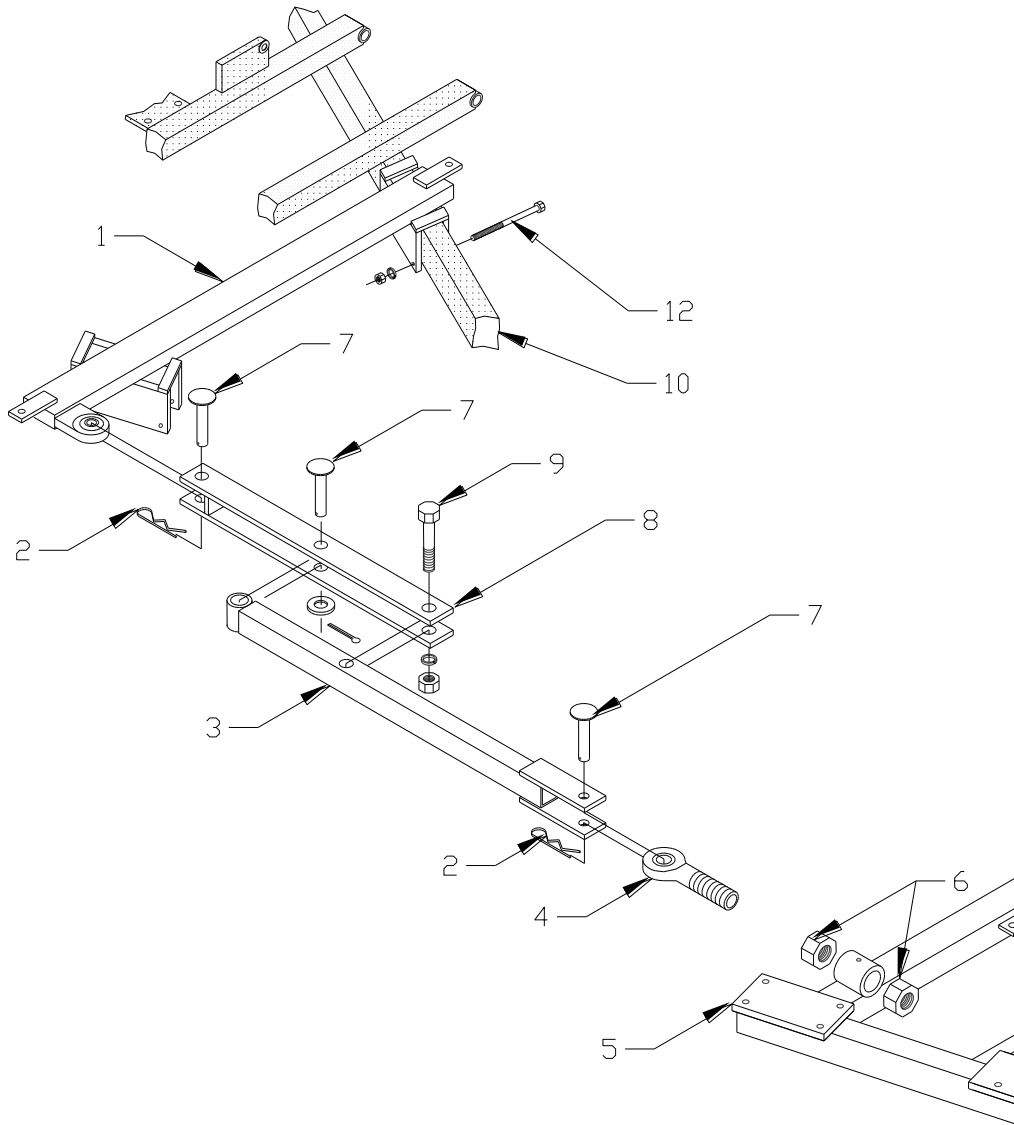

TD92 CONNECTING LINK:

The connecting link is used to lock and stabilize the Pro-Max 36 and the TD92 mowers together. It is important that the link be mounted correctly and set at the proper length. This will ensure that the two mowers are travelling parallel and cutting properly. Follow these steps for installation.

1. After connecting the mower to the back of the Pro-Max 36, drive the unit forward a short distance, while making a slight turn to the right. This will shorten the length between the two mowers on the right hand side for mounting the link.
2. Remove the pivot lock pin from the link allowing it to pivot out and shorten.
3. Mount the link to the bracket on the TD92 mower.
4. Mount the other end onto the back of the Pro-Max 36 mower.
5. Now push the link in straight, or slowly drive the mower forward with a slight turn to the left so the connecting link straightens. Replace the locking pin.
6. Using the connecting link adjustment bolt, adjust the length of the link until the TD92 mower is in position straight behind the Pro-Max 36.
7. **Remove the transport castor lockout bars from the unit.**



Connecting Link Adjustment Bolt

Pivot Lock Pin

Link Bent Out To Connect

TD92 Safety Chain

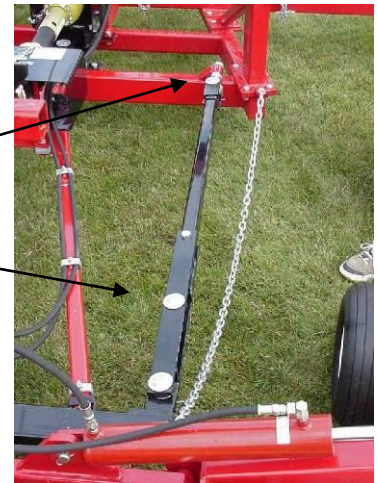

Pro-Max 36 Castor Lockout Bar



CONNECTING THE PTO SHAFT:

1. Ensure that the tractor engine is shut off and the parking brake is locked.
2. Holding the PTO against the end of the tractor PTO shaft, rotate the tractor PTO by hand until the shaft slides on slightly.
3. Slide the locking collar on the PTO backwards, releasing the locking mechanism, hold and slide the PTO on.
4. Release the ring and pull the PTO backwards until the locking mechanism snaps into place.
5. Push the shaft forward and backward to ensure that it is securely locked into place.

! CAUTION!

If the PTO shaft comes off during operation, it may cause personal injury and damage to the PTO shaft and tractor PTO. When checking, make sure the locking collar is locked, and that the shaft is not just jammed against the end of the tractor PTO shaft.

CHECK PTO LENGTH DURING TURNS:

During the mowing operation, the tractor should be able to make turns without damage to the driveline. To ensure proper setup, check the following conditions:

1. With the tractor in the lowest gear and travelling very slowly, make a sharp turn to the right.
2. Watch the PTO shielding to make sure the PTO shaft does not totally collapse. There should be 1" to 2" of black PTO shielding left at maximum turn. (see picture below)



OPERATION OF THE MOWER:

A careful and knowledgeable operator is the best insurance against an accident.

Allow no riders on any equipment.

If the tractor is equipped with a R.O.P.S., use the seat belt for maximum protection.

Make sure that everyone is clear of the tractor and mower before starting the engine or operating.

DAILY CHECK LIST:

1. Check that mower is properly and securely attached to tractor and the safety chain is attached.
2. Ensure all safety shielding is properly installed, Check that all nuts and bolts are secure and pins are properly cotter pinned.
3. Check condition of blades and security of attachment.
4. Ensure mower cutting height is properly adjusted.
5. Clear area of stones, branches or other debris that might be thrown causing injury or damage.
6. Never permit any person other than the operator to ride or board the tractor at any time.
7. Check that all lubrication points with grease fittings have been lubricated as per schedule.
8. Check all gearboxes for proper amount of gear oil. Mower must be on level surface when this is done.
9. Be sure actuator pull rope is properly secured and will not become entangled in PTO shaft.

PROPER TORQUE FOR FASTENERS:

The chart lists the correct tightening torque for fasteners on Progressive Turf Equipment mowers. When bolts are to be tightened or replaced, refer to this chart to determine the proper torque except when specific torque values are assigned in the manual. Only SAE grade 5 fasteners are to be used in the assembly of this machine, or as otherwise specified in this manual.

BOLT HEAD MARKINGS

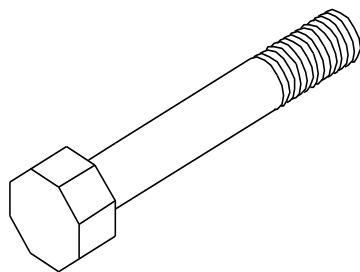

SAE Grade 2
(No dashes)

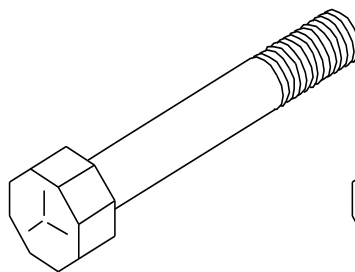

SAE Grade 5
(3 radial dashes)

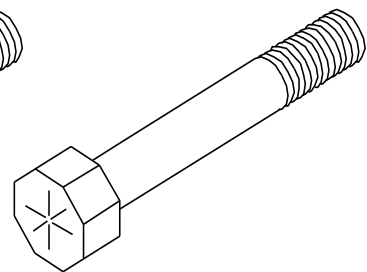

SAE Grade 8
(6 radial dashes)

Bolt Diameter (in.) (SAE Grade 5 Bolts)	Recommended Torque in Foot Pounds (Newton-Meters)
5/16	21 (28)
3/8	38 (52)
7/16	55 (75)
1/2	85 (115)
9/16	125 (170)
5/8	175 (240)
3/4	300 (410)
7/8	450 (610)
1	680 (925)
1" LH Spindle Nut	60 (82)

CUTTING HEIGHT AND ADJUSTMENT:

Mower cutting height adjustment is made by removing the lynchpin from the top of each castor stem (square or round) and corner support, and moving the spacers either above or below support tube as required for your selected cutting height.

Be sure all adjustments are set the same.



When setting the cutting height on the Pro-Max 36, be sure to use the wing safety chains. The chains are located in the box just below and behind the main gearbox on the mower.

Mount chain
in top hole.



Safety Chain

Two holes on frame to anchor the safety chain.

- Inside hole for blade change.
- Outside hole for cutting height change.

LOWERING THE WING DECKS:

Any time the wings are raised and work is being done on the decks, the wing safety chains must be installed. Refer to the section on Maintenance.

When operating the PRO-MAX 36, the hydraulic control valve operating the wings must be in FLOAT position. This will allow the wings to follow the contour of the ground. If the valve is not in float, the mower will not cut evenly.

DECK POSITION BUSHING:

Spacer
Bushing



This spacer bushing can be mounted on either side of the wing deck swivel. Bushing shown mounted on the inside, positioning the wings out as far as possible. This will give maximum cutting width. Moving the bushing to the outside will increase the deck cutting overlap and reduce the overall cutting width. This will, however, reduce the width of the uncut strip when making turns. This position will be used when mowing while following a pivot track.

TIRES:

Upon receiving your mower, check air pressure in the tires and adjust according to specifications.

TIRE TYPE	RECOMMENDED TIRE PRESSURE (PSI)
MOWER DECK TIRES (CASTORS)	24 PSI
MAIN FRAME TIRES	32 PSI

CAUTION!

Never inflate tires beyond 35 pounds per square inch to seat beads. Inflation beyond 35-PSI pressure before seating the bead may break the bead or even the rim with explosive force. If beads have not seated by the time the pressure has reached 35 PSI, deflate the assembly, move tire to another position on the rim and re-lubricate. Inflate tire and inspect both sides of the tire to be sure beads are

seated properly. If not, deflate the tire, unseat beads and repeat the above mounting procedure. After properly seating beads, adjust to pressure recommended. (See above specs.)

POWER TAKE-OFF SHAFTS:

⚠ CAUTION!

Keep all shields in place.

⚠ CAUTION!

When operating the PTO, be sure the tractor shield is always in place, covering the exposed PTO shaft.

⚠ WARNING!

Before dismounting from the tractor, stop the PTO, put the tractor in neutral, set the brakes in lock position and shut off engine.

⚠ CAUTION!

When ready to engage PTO shaft, be sure engine RPM is at idle speed. Engaging PTO at full throttle will cause high shock loads to driveline, with the potential for future failure.

NOTE: Do not exceed the recommended PTO speed of 540 RPM.

LUBRICATION:

A properly maintained lubrication schedule will provide a smooth running machine for many years.

All pivot locations have grease fittings. The following information shows and describes where all lubrication points are located. Use a quality EP2 bearing grease or equivalent.

<p>DECKS</p> <ul style="list-style-type: none"> • SPINDLES* (SEE MANUAL) • 3 PIVOTS PER WING DECK* • 2 PIVOTS ON REAR DECK* • CASTOR WHEEL & SWIVELS* <p>*(AS REQUIRED)</p>	<p>P.T.O SHAFTS</p> <ul style="list-style-type: none"> • MAIN INPUT • DECK DRIVE – 4 LOCATIONS PER SHAFT* • PULL APART SLIDING TUBES ONCE PER WEEK AND LUBRICATE <p>*(AS REQUIRED)</p>	<p>FRAME</p> <ul style="list-style-type: none"> • 8 PIVOT LOCATIONS* • 2 WHEELS* <p>*(AS REQUIRED)</p>
<p>CHECK FOR PROPER OIL LEVEL IN GEARBOXS DAILY</p>		
<p>GREASING SCHEDULE & LOCATIONS</p>		

An Important Word On Grease Compatibility

What Grease Is:

-Grease is essentially a distilled petroleum product in the form of mineral oil (or a synthetic) which has a thickening agent such as lithium, calcium, barium, sodium, or aluminum.

-Many of the thickeners will work for similar situations, but **when mixing greases with different thickeners, one must review compatibility**. Grease incompatibility will actually decrease the lubrication ability of the grease, and cause premature part failure.

-There may be other additives in the grease that impart special properties. These properties may be “high temperature”, “extreme pressure”, etc.

What We Use:

- Our bearing supplier uses Shell Alvania 2
- Progressive uses Texaco Multifak EP 2
- EP means extreme pressure
- Both greases have:
 - A mineral oil base
 - A lithium thickener
 - The mineral oil has a NLGI Grade 2
 - Both greases are compatible with each other

Note:

-If a thickener other than lithium is used, the existing grease will be contaminated and the lubrication properties may be lost.

-If a synthetic base oil is used rather than a mineral base oil, the grease will again be contaminated and the lubrication properties may be lost

-Molybdenum Disulfide (Moly) is an additive used in slow moving, extreme load applications. The particles in the “Moly” will actually increase bearing wear in a mower spindle. Our grease does not contain Moly.

-The blade spindle temperature should never go above 120°F if properly greased; we do not recommend high temperature grease.

A grease with these features is considered to be a “General Purpose Grease”. Use on all grease point locations on your Progressive Mower.

Our Recommendation for Grease Compatibility:

The grease you use for the blade spindle assemblies must have these properties:

- NLGI grade 2
- Lithium thickener (NOT LITHIUM COMPLEX OR LITHIUM 12-HYDROXY
- Dropping Point Less than 400° F
- General Purpose Grease, Not Heavy Duty
- No MOLY (molybdenum disulphide) additives in the grease
- No synthetic grease
- No High Temperature Grease
- Check the properties of the grease you wish to use with your supplier prior to use.

TRANSPORTING THE MOWER:

! CAUTION!

When traveling on public roadways, use flashing amber lights and Slow Moving Vehicle sign on the rear of the mower to provide greater visibility to other traffic.

Once a mower is in the raised position, activate tractor hydraulic control valve (on the 22 ft unit) slightly so that the cylinders will extend and allow the locks to be totally engaged. This way there will be no sudden surges on the hydraulic system when traveling over rough terrain.

! WARNING!

When towing this mower, the following information concerning road speed should be strictly adhered to.

WEIGHT OF TOWING VEHICLE	MAXIMUM ALLOWABLE ROAD SPEED
4500 LBS OR MORE	UP TO 20 MPH (32 KM/H)
2300 LBS – 4500 LBS	UP TO 10 MPH (16 KM/H)
2300 LBS OR LESS	DO NOT TOW

! CAUTION!

Always have a safety chain attached to towing vehicle.

SAFETY CHAINS:

It is recommended that the safety chains provided with this mower be attached to the towing vehicle at all times.

Install the safety chain as shown. After attaching the safety chain, make a test run to the left and right for a short distance to check for proper adjustment. Readjust to eliminate a loose or tight chain.

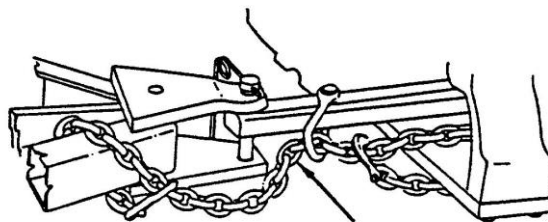

Figure 3 SAFETY CHAIN

Safety chains are also provided for the rear TD92 Mower. These must be connected to the rear of the Pro-Max 36 at all times.

Be sure they are securely fastened for road transport.



DECK LOCK PINS ON Pro-Max 36:

Lock both wings during road transport. This will prevent the wings from swinging back during transport, therefore eliminating damage. Always unlock the decks before lowering the wings.



Pin shown in field working position.



Shown in locked position.

WING LOCK PINS Pro-Max 36:

The wing lock pins must be installed during transport to ensure the wings do not lower.



Wing safety lock pins

TRANSPORTING THE PRO-MAX 36 ONLY:

When transporting the Pro-Max 36 without the TD92 mower attached to the rear, the castor wheel lockout bars must be installed.

The two lockout bars are stored on the front side of the crossbrace tube on the main hitch frame.

Park the unit with the castoring transport tires turned to the rear and the tractor straight to the machine. Disconnect the TD92 mower from the Pro-Max 36, remove the connecting link and safety chains.

Using two 7/16" bolts, mount the lockout bar as shown below.



DISCONNECTING TD92 FROM PRO-MAX 36

The TD92 may be disconnected from the Pro-Max 36 for small mowing jobs where the 36' cutting ability of the Pro-Max 36 is not suitable.

Care should be taken in doing this. The procedure is the reverse of the hook up instructions found in this manual.

IMPORTANT: the TD92 has its own critical drawbar dimensions as outlined in the TD92 manual. These must be observed or damage to driveline components will occur. The original safety cord from the TD92 must also be used.

MAINTENANCE:

WARNING!

Turn tractor engine off before performing any maintenance.

CAUTION!

Always use personal protection devices such as eye and ear protectors when performing maintenance functions.

WARNING!

When completing a maintenance or service function, make sure all safety shields are installed before placing the mower in service.

BLADE SERVICING:

WARNING!

Be sure safety locks are in place when working on decks in the raised position. The tractor hydraulic system could fail, causing decks to fall and crush anything under them.

Do not handle mower blades with bare hands. Careless or improper handling may result in serious injury.

Inspect blades before each use to determine that they are mounted tightly and are in good condition. Replace any blade that is bent, excessively nicked, worn or has any other damage. Small nicks can be ground out when sharpening.

WARNING!

Only original equipment blades should be used when replacing worn-out mower blades. They are made of special steel alloys and subjected to rigid heat-treating and inspection requirements. Substitute blades may not meet these rigid specifications and **MAY BE DANGEROUS.**

BLADE REMOVAL AND INSTALLATION:

Two, 1/2" x 1 3/4" grade 5 bolts with lock washers and nuts hold the blade to blade spindle support bar. When changing blades, be sure that these fasteners are in good condition so they will not come loose during operation.

BLADE SHARPENING:

IMPORTANT – When sharpening blades be sure to balance them. Unbalanced blades will cause excessive vibration that can damage blade spindle bearings. Vibration may cause structural cracks in mower housing.

Follow original sharpening pattern as shown. Sharpen blade to a razor edge. Protect hands when sharpening. Do not sharpen back side of blade.

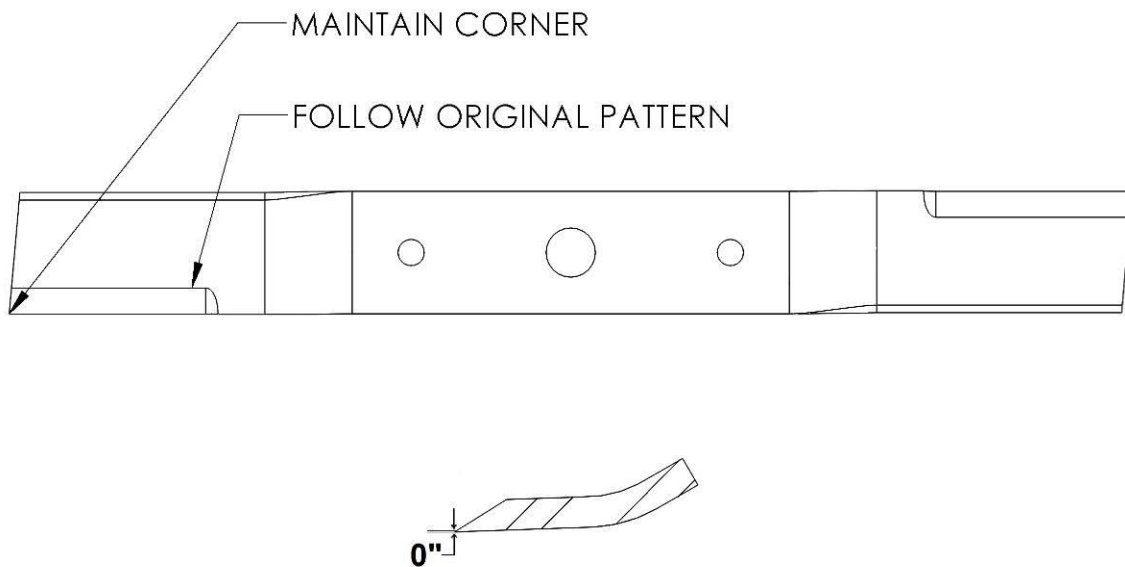

SPINDLE INSPECTION:

Spindles are equipped with two ball bearings. Adjustment is set by tightening the 1" NF left hand nut to 60 ft-lbs torque for proper setting.

Periodically inspect blade spindles by grasping pulley, and moving from side to side. If any free play is noted, replace or repair.

SPINDLE ASSEMBLY REMOVAL:

Remove blade from spindle.

Remove belt shield. Loosen 4 bolts that hold gearbox to mount.

Loosen 1/2" x 3 1/2" tap bolt and slide gearbox toward front until belt becomes slack and is easy to remove.

Remove belt.

Remove 4 bolts attaching spindle assembly to mower deck and remove as a unit, since pulley will come out through the hole in the deck.

SPINDLE ASSEMBLY INSTALLATION:

Reverse above procedure. Be sure spindle mounting area of deck is clean of any foreign material before attaching spindle assembly.

SPINDLE REPAIR:

Spindle repair requires special skills and tools. If your shop is not properly equipped or your mechanics are not properly trained in this type of repair, it may be in your best interest, both time and money wise, to use a new spindle assembly.

Remove pulley from spindle assembly. Place the assembly in a press and force spindle down through housing. Once pressed apart, replace bearings as removal will have damaged bearings internally.

ASSEMBLY OF SPINDLE:

Only use a press that has the ram and bed 100% square to each other. If bearings are not square in housing, bearings will wear out prematurely. Press on outer race when inserting into hub and press on inner race when installing on spindle.

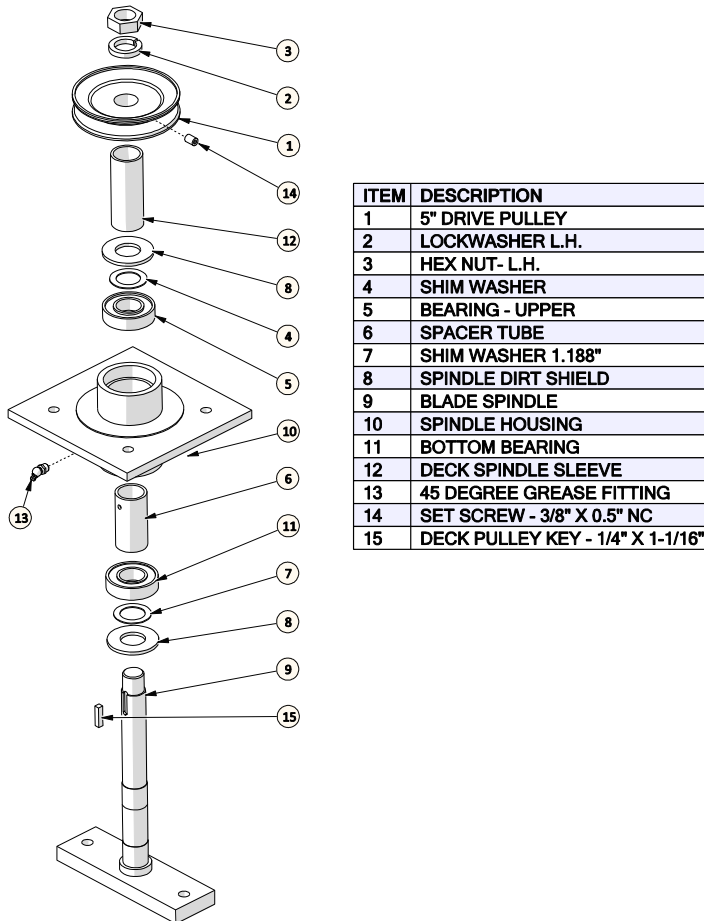

If bearings are being changed, be sure to check bearing spacer for wear. If wear is noticed, insert new spacer. This is critical because if spacer is short by only .010", the top bearing will start to bind and will result in premature failure.

Bearing with seal and shield combination will be pressed into the blade side of the hub first with the seal side facing out. Next; set spindle on press bed.

Install dirt shield and shim first (see sketch above), set hub, bearing end down, on to spindle. You must use a tube (Note: both ends must be square) which will slide over spindle and press on inner race

of bearing, until seated against shim.

Insert bearing spacer tube with hole end up. Set the remaining bearing, with shield side up, open side on first, on to spindle. Press on inner race (this bearing will be a loose fit in the hub so it will seat itself properly).

When all parts have been installed on the spindle, torque **left hand nut** to (60) ft.lbs, and then tighten set screws in pulley. Once the assembly is complete, fill the spindle with quality grease until it exits the top bearing. Rotate the housing six revolutions by hand so the bearings will have the grease worked into them, and at the same time, check for free movement. The assembly is now ready for installation into the mower deck.

“V” BELT ADJUSTMENT:

Begin by loosening 4 bolts at the base of the gearbox, adjusting the long threaded bolt slides the gearbox back, therefore tightening the belts. After proper tension is achieved, tighten 4 bolts at base of gearbox. You may have to place a 1/2” nut under the head of the long-threaded bolt to increase your adjustment length.

When changing belts, removal of the grease fitting from the top of the center spindle will make installation easier. Be sure the belts run in the proper groove.

“V” BELT TENSION:

Proper belt tension is a fundamental factor in the successful V-belt operation. Lack of tension will cause slippage, and too much tension will cause excessive belt stretch as well as damage to the drive components, such as bearings and shafts. Therefore, to ensure proper belt tension, the following procedure is recommended.

At the mid-point of the span, apply a deflection force with a spring scale in the direction perpendicular to the span until the belt is deflected 3/8”.

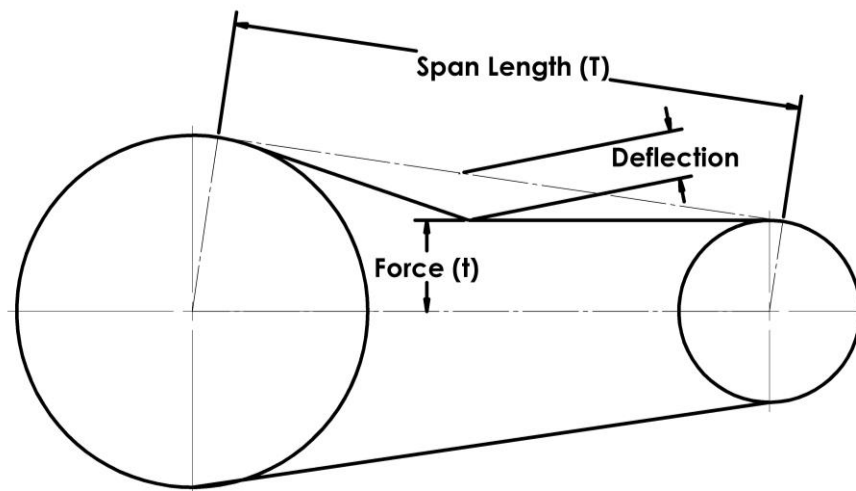

The recommended force to deflect the belt is a minimum of 4.9 lbs. to a maximum of 7.3 lbs.

The first 24 to 48 hours of operation is the belt “run in” period. To ensure satisfactory belt performance, belt tension should be checked during this time period.

HYDRAULICS:

The hydraulic system on your Progressive mower is a simple cylinder system used to raise and lower the cutting decks into position. Each cylinder contains a .035 diameter restrictor orifice, which is located on the rod end to slow the speed of travel.

Restrictor Orifice



When reconnecting the quick disconnects to the tractor, be sure that both ends are clean. Dirt in the hydraulic system can block the orifice in the line throttle valve or even score the cylinder tubes.

Hydraulic fluid escaping under pressure has enough force to penetrate the skin. Seek medical attention at once if injured by escaping fluid. During your daily inspection repair all leaks before they create a major problem. Relieve all pressure before working on, or disconnecting the line in the hydraulic system.

If crimp-on hose ends are ever changed, be sure they are compatible with the hose, to provide the proper crimping pressure.

TROUBLESHOOTING:		
PROBLEM	CAUSE	REMEDY
VIBRATION WHEN TURNING	DRAWBAR LENGTH INCORRECT	CHECK DRAW BAR LENGTH SPECS AND ADJUST HITCH PLATE
VIBRATION WHEN TURNING	MAIN INPUT SHAFT NOT COLLAPSING EASILY	PULL INPUT SHAFT APART AND GREASE INNER AND OUTER SPLINES. NOTE THERE ARE TWO GREASE ZERKS AT MIDSHAFT. GREASE BOTH EVERY 8 HOURS OF USE.
INTERMEDIATE PTO SHAFT DAMAGE TO SPLINED STUB.	MAIN INPUT SHAFT IS NOT COLLAPSING EASILY DUE TO INSUFFICIENT GREASE ON SPLINES	REPEAT AS PER ABOVE. IN HOT OPERATING TEMPERATURES GREASE EVERY 4 HOURS
PREMATURE SPINDLE BEARING DAMAGE	INSUFFICIENT GREASE ON BEARINGS	GREASE EVERY 8 HOURS OF USE. IN HOT TEMPERATURES GREASE EVERY 4 HOURS.
PREMATURE SPINDLE BEARING DAMAGE. GREASE IS BLACK, DRY AND PASTY ON EXAMINATION	CONTAMINATED GREASE	SEE INFORMATION ON GREASE COMPATIBILITY IN THIS MANUAL
FRONT DECKS CUT HIGHER/LOWER THAN REAR DECKS	TRACTOR HYDRAULIC CONTROL NOT IN FLOAT POSITION	WHEN LOWERING DECKS, BE SURE THE FRONT SECTION IS IN FULL FLOAT POSITION
ONE DECK ON FRONT SECTION GIVING A RAGGED CUT	THE FOUR WAY GEAR BOX MOUNTED INCORRECTLY AND THE BLADES ARE TURNING IN WRONG DIRECTION	WHEN MOUNTING FOUR WAY GEARBOX THE BREATHER MUST BE IN THE REAR RIGHT HAND SIDE LOOKING AHEAD

Parts List

PRO-MAX 36

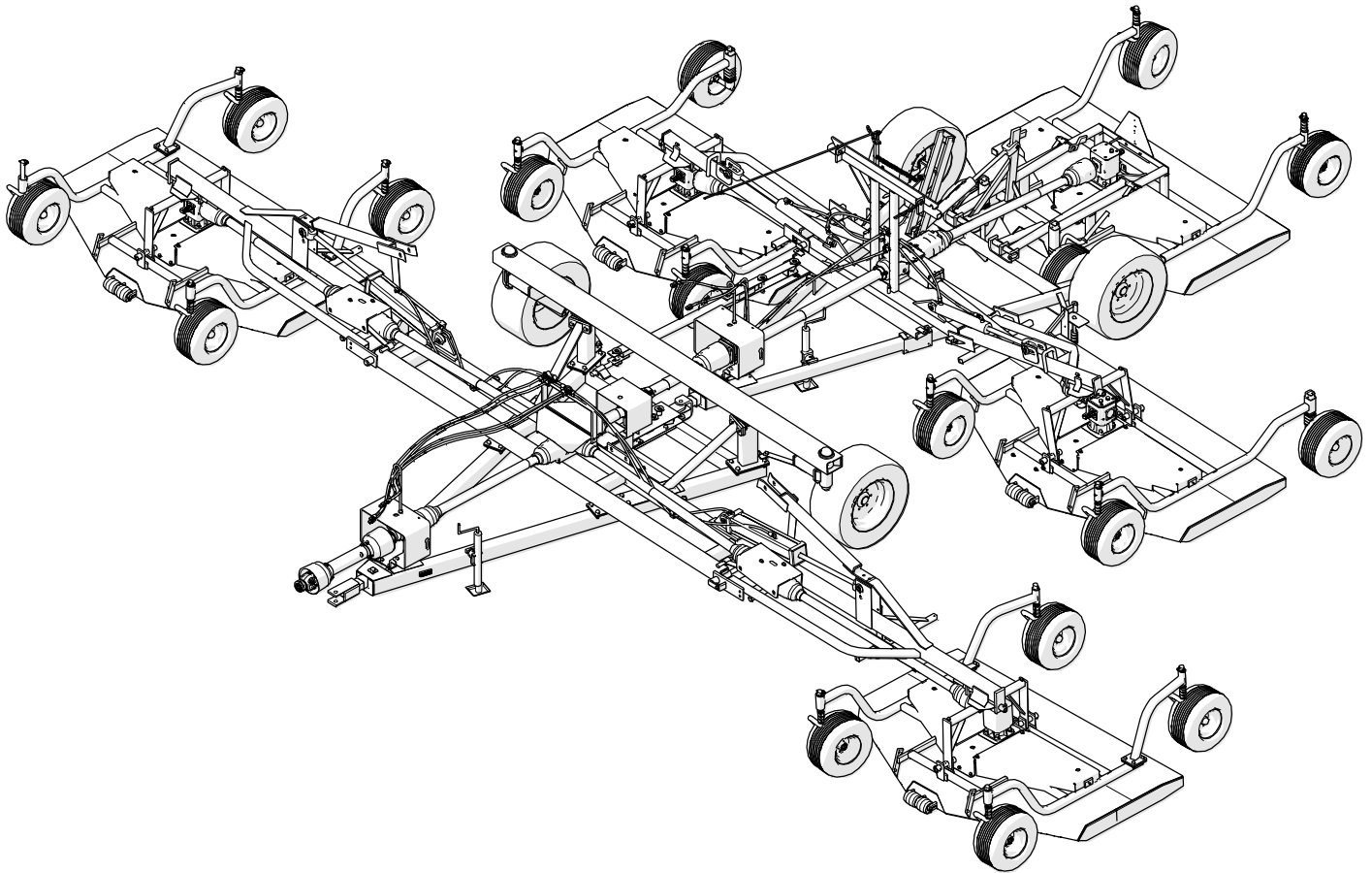

Model: PM-36

Effective serial number: 1336228 and up.

P.N. 120515

Issue Date: January 2014

 **DANGER!**

Si No Lee Ingles, Pida Ayuda a Alguien Que Se Lo Lea
Para Que le Traduzca Las Medidas de Seguridad

Serial Number Location

The serial number plate for the machine is located on the left side of the main frame tube at the front of the machine.

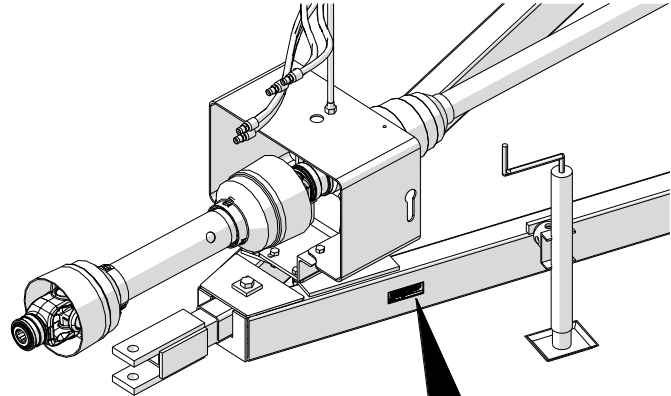

For quick reference, record the following information:

Model: _____

Serial Number: _____

Date purchased: _____



Always state this information when contacting your selling dealer and when ordering spare parts.

Parts Information

Use only Genuine Original Equipment Manufacturers (O.E.M.) replacement parts. The use of "will fit" parts may reduce machine performance, void machine warranties and present a safety hazard. Use Genuine OEM parts.

Progressive Turf Equipment Inc.

137 West William Street
Seaforth, Ontario
Canada
N0K 1W0

Phone: 800-668-8873

Fax: 519-527-2275

www.progressiveturfequip.com

Maintenance

Maintenance should always be performed by a qualified service technician familiar with servicing similar equipment, using good safety and workmanship practices.

Always observe proper lock-out procedures when performing any maintenance work. Other than maintaining the blade spindles or blades, always lower all decks before performing maintenance. Block and or support machine using equipment designed for the task. When maintaining blades or spindles, always ensure locks are seated correctly in place. When performing hydraulic maintenance, ensure that pressure has been released.

It is imperative that the operator or qualified service technician reads and understands all the safety information in the Operator's Manual before proceeding. Failure to follow the instructions or heed the warnings could result in injury or death.

Proper care is your responsibility.

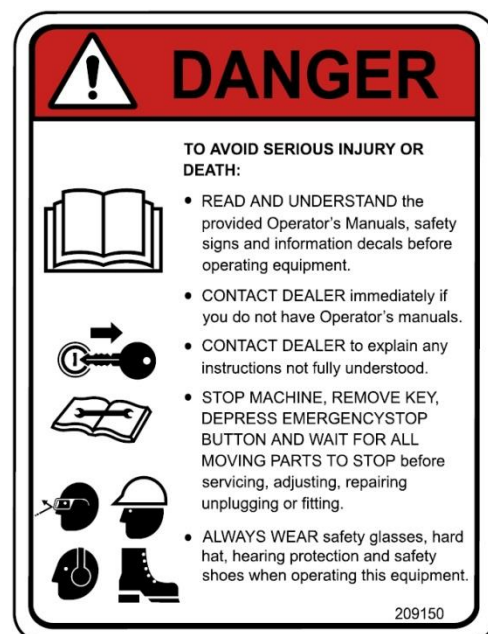

PARTS ORDERING GUIDE

The following instructions are offered to help eliminate needless delay and error in processing purchase orders for the equipment in this manual.

1. The Parts Section is prepared in logical sequence and grouping of parts that belong to the basic machine featured in this manual. Part Numbers and Descriptions are given to help locate the parts and quantities required.
2. The Purchase Order must indicate the Name and Address of the person or organization ordering the parts, who should be charged, and if possible the serial number of the machine for which the parts are being ordered.
3. The purchase order must clearly list the quantity of each part, the complete and correct part number, and the basic name of the part.
4. The manufacturer reserves the right to substitute parts where applicable.
5. Some parts may be unlisted items which are special production items not normally stocked and are subject to special handling. Request a quotation for such parts before sending purchase order.
6. The manufacturer reserves the right to change prices without notice.

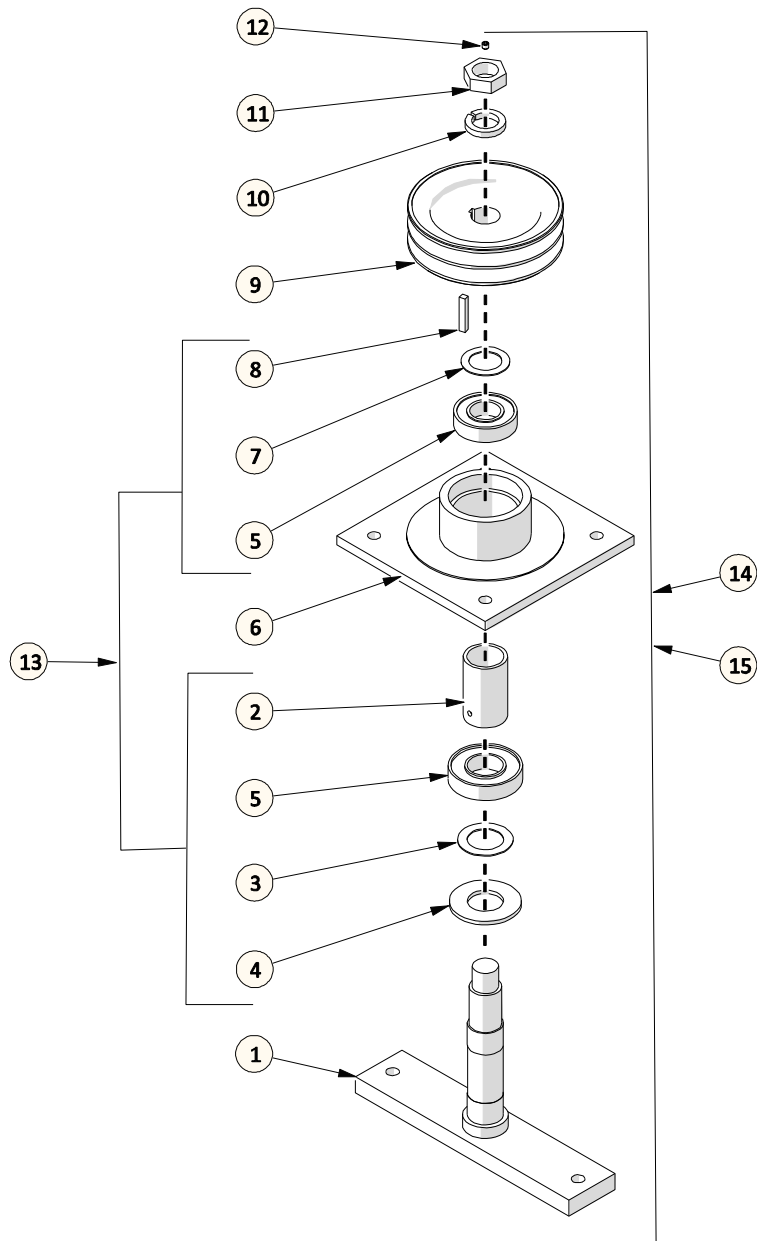

Table of Contents

1	DECK ASSEMBLY	2
1.1	BLADE SPINDLE ASSEMBLY.....	2
1.2	BLADE OPTIONS	3
1.3	GEARBOX ASSEMBLY	4
1.4	DECK ASSEMBLY	5
2	FRAME ASSEMBLY	6
2.1	MAIN FRAME.....	6
2.2	WING FRAME	7
2.3	CONNECTING FRAME.....	8
2.4	CASTER ARM ASSEMBLIES	9
2.5	TIRE ASSEMBLIES	10
3	HYDRAULICS	11
3.1	HYDRAULICS	11
4	DRIVELINE.....	12
4.1	DRIVELINE.....	12
4.2	INPUT PTO SHAFT	13
4.3	INTERMEDIATE PTO SHAFT.....	14
4.4	DECK PTO SHAFT	15
4.5	REAR OUTPUT PTO SHAFT	16
4.6	DECK GEARBOX.....	17
4.7	4 WAY GEARBOX.....	18
5	DECALS	19
5.1	SAFETY	19
5.2	GENERAL INFO	21

1 DECK ASSEMBLY

1.1 Blade Spindle Assembly



ITEM	PART #	DESCRIPTION	QTY
1	521010	BLADE SPINDLE	1
2	-	BEARING SPACER TUBE	1
3	-	1-3/8" SHIM WASHER	1
4	-	DIRT SHIELD	1
5	-	BEARING	2
6	521006	SPINDLE HOUSING	1
7	-	SHIM WASHER - 1.25"	1
8	O.L.	KEY - 1/4" X 1-9/16"	1

ITEM	PART #	DESCRIPTION	QTY
9	521775	PULLEY - 5.9"	1
10	521002	LOCKWASHER L.H. (3 PCS)	1
11	521003	HEX NUT- L.H.	1
12	O.L.	SET SCREW - 1/4-28 X 1/4	1
13	521980	SPINDLE REBUILD KIT	1
14	521959	BLADE SPINDLE ASSEMBLY (COMPLETE)	1
15	521960	SPINDLE ASSEMBLY W/O PULLEY	1

O.L. - OBTAIN LOCALLY

1.2 Blade Options

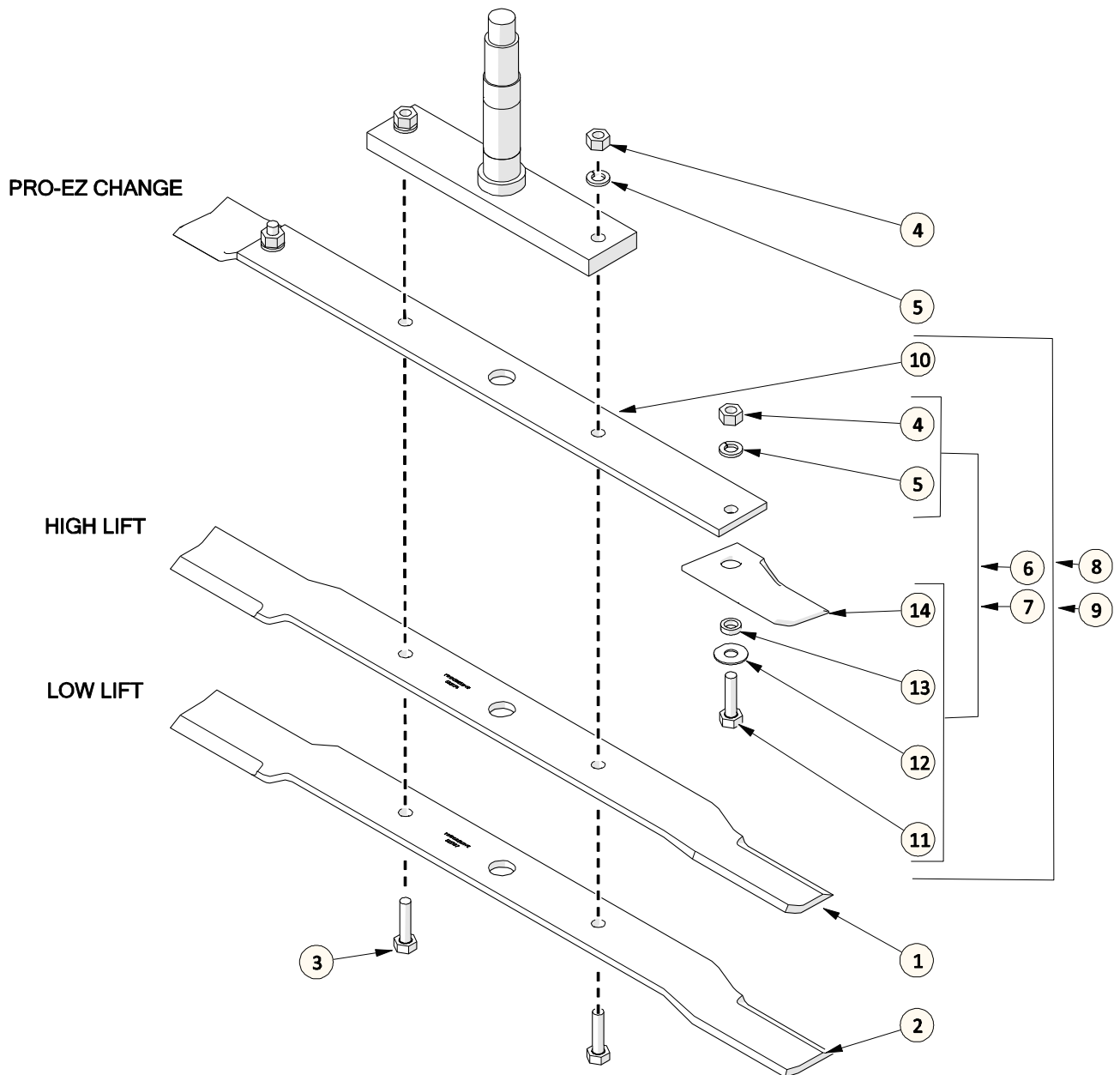

ITEM	PART #	DESCRIPTION	QTY
1	522605	BLADE KIT - STANDARD LIFT (9 PCS)	1
2	522608	LOW LIFT BLADE KIT (9 PCS)	1
3	-	HEX BOLT- 1/2" X 1.75 NC GR5 PL	2
4	-	HEX NUT - 1/2"NC GR5 PL	4
5	-	LOCK WASHER- 1/2 PL	4
6	526596	HIGH LIFT BLADE TIP KIT W/HW - 50 BLADE TIPS (ITEMS 4-7)	1
7	526636	LOW LIFT BLADE TIP KIT W/HW - 50 BLADE TIPS (ITEMS 4-7)	1
8	526586	SINGLE HIGH LIFT PRO-EZ CHANGE ASSEMBLY	1
9	526634	SINGLE LOW LIFT PRO-EZ CHANGE ASSEMBLY	1
10	-	BLADE BAR (SEE ITEM 15)	1
11	-	HEX BOLT- 1/2" X 1.25 NC GR8 PL	2
12	O.L.	FLAT WASHER- 7/16" PL HARDENED	2
13	526590	BLADE SPACER KIT (25 PCS)	2
14	-	BLADE TIP (SEE ITEMS 6 & 7)	1
15	526652	BLADE BAR KIT (6 PCS)	1

O.L. - OBTAIN LOCALLY

1.3 Gearbox Assembly

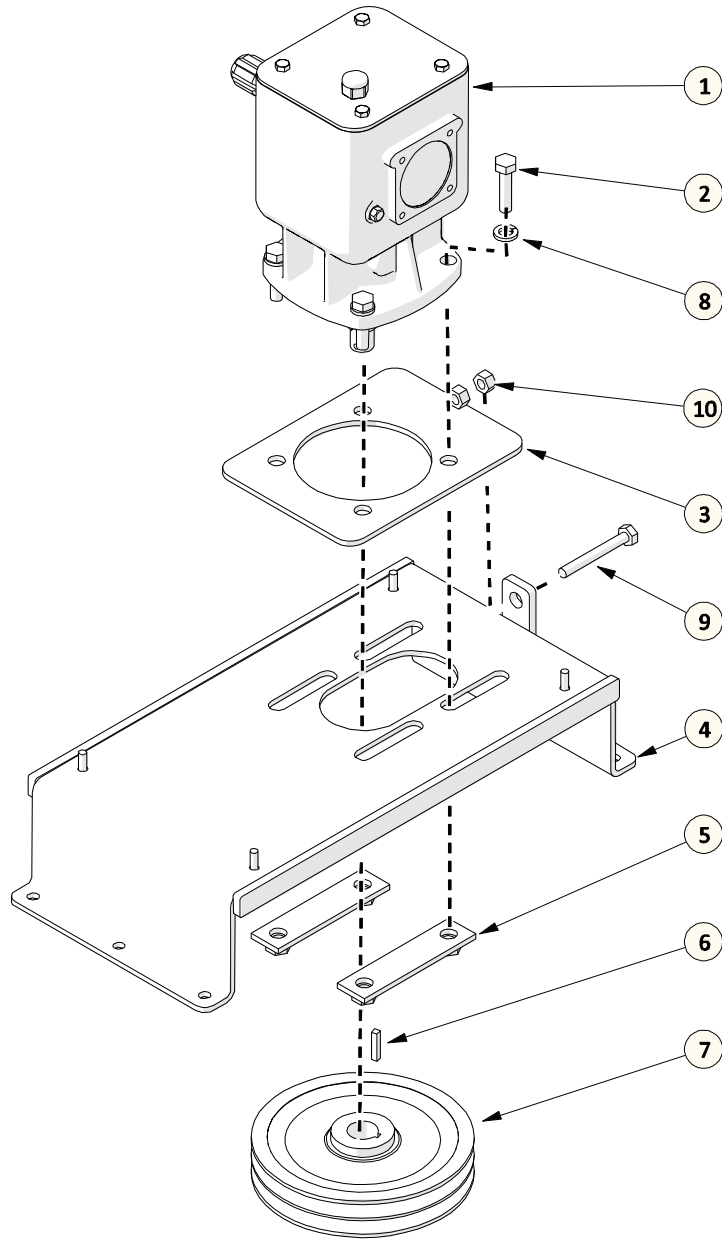

ITEM	PART #	DESCRIPTION	QTY
1	521432	DECK GEARBOX	1
2	O.L.	HEX BOLT- 9/16 X 2 NC GR5 PL	4
3	521013	SLIDE PLATE	1
4	521019	GEAR BOX MOUNT	1
5	521018	STIFFENER NUT BRACKET	2
6	521390	KEY - 1/4 X 1-5/16 (3 PCS) KIT	1
7	521774	MAIN DRIVE PULLEY - 8.7"	1
8	O.L.	LOCK WASHER- 9/16 PL	4
9	521020	TAP BOLT KIT (3 PCS)	1
10	O.L.	HEX NUT - 1/2NC GR5 PL	1

O.L. - OBTAIN LOCALLY

1.4 Deck Assembly

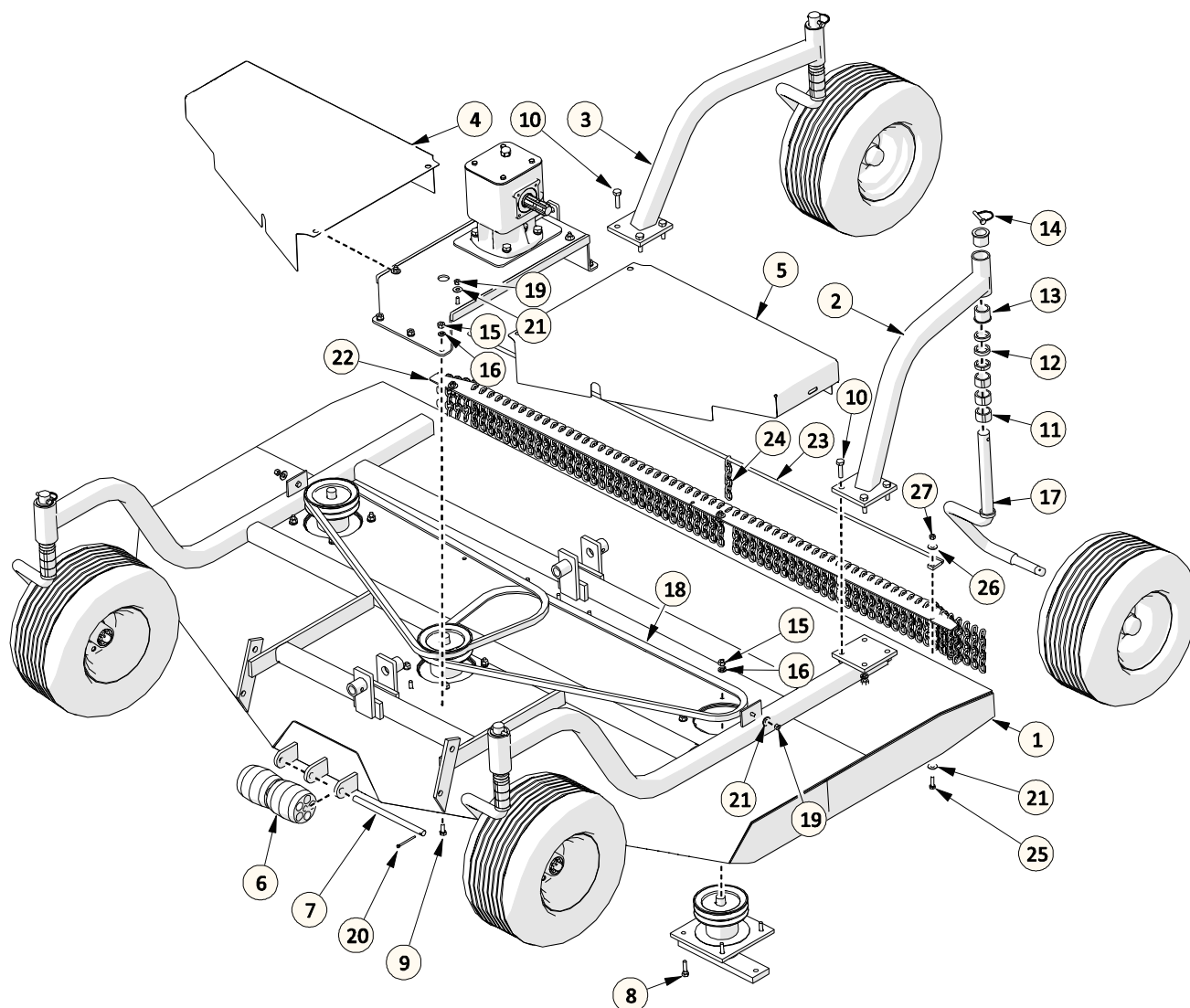

ITEM	PART #	DESCRIPTION	QTY
1	523141	MOWER DECK	1
2	523149	DECK CASTER ARM -RH	1
3	523150	DECK CASTER ARM - LH	1
4	521400	BELT GUARD - R.H.	1
5	521401	BELT GUARD - LH	1
6	209001	ANTISCALP ROLLER 4-1/4"	2
7	522400	ANTI-SCALP PIN - LONG	1
8	O.L.	HEX BOLT- 7/16 X 1.5 NC GR5 PL	12
9	O.L.	HEX BOLT- 7/16 X 1 NC GR5 PL	6
10	O.L.	HEX BOLT- 1/2 X 1.75 NC GR5 PL	8
11	521030	SPACER KIT - 1" (6 PCS)	1
12	521029	SPACER KIT - 3/8" (6 PCS)	1
13	521831	PRESS IN BUSHING - 1-1/4"	1
14	521844	ROUND LYNCH PIN KIT (6 PCS)	1

ITEM	PART #	DESCRIPTION	QTY
15	O.L.	HEX NUT - 7/16NC GR5 PL	18
16	O.L.	LOCKWASHER - 7/16 PL	18
17	521503	CASTER ARM	4
18	521034	BELT - B90	2
19	O.L.	HEX LOCK NUT - 3/8 NC GR5 UPL	6
20	O.L.	COTTER PIN - 3/16 X 1.5	1
21	O.L.	FLAT WASHER- 3/8 PL	8
22	521633	CHAIN GUARD PLATE (OPTIONAL)	1
23	521629	CHAIN GUARD WELD 22' REAR (OPTIONAL)	1
24	521618	CHAIN REPLACEMENT KIT (OPTIONAL)	1
25	O.L.	HEX BOLT - 3/8 x 1.25 NC GR5 PL	2
26	O.L.	LOCK WASHER- 3/8 PL	2
27	O.L.	HEX NUT - 3/8NC GR5 PL	2

O.L. - OBTAIN LOCALLY

2 FRAME ASSEMBLY

2.1 Main Frame

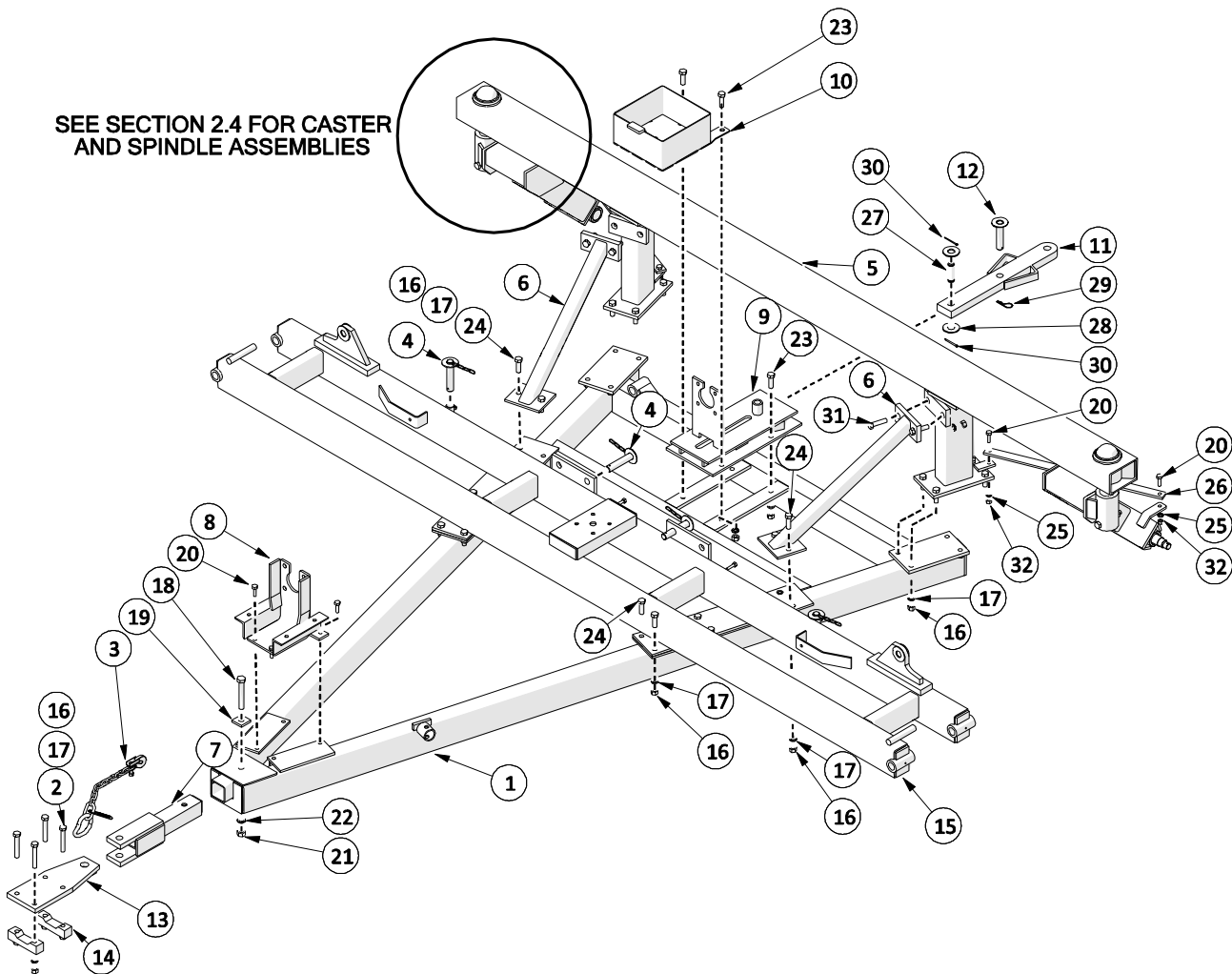

ITEM	PART #	DESCRIPTION	QTY
1	523131	MAIN FRAME	1
2	O.L.	HEX BOLT- 5/8 X 4 NC GR5 PL	4
3	521048	SAFETY CHAIN	1
4	523138	WING LOCK PIN	4
5	523133	CASTER FRAME	1
6	523088	CROSS FRAME BRACE	2
7	523143	HITCH	1
8	523182	FRONT PTO SUPPORT	1
9	523061	REAR PTO SUPPORT	1
10	523094	CHAIN BOX	1
11	523051	DRAW BAR - REAR	1
12	523158	PIN - 1" X 4-3/4"	1
13	523167	ADJUSTABLE HITCH PLATE	1
14	523082	ADJUSTABLE HITCH LOCK BAR	2
15	523130	WING FRAME	1
16	O.L.	HEX NUT - 5/8	36
17	O.L.	LOCK WASHER- 5/8 PL	36

ITEM	PART #	DESCRIPTION	QTY
18	O.L.	HEX BOLT- 3/4 X 5 NC GR5 PL	1
19	521857	SAFETY CHAIN WASHER	1
20	O.L.	HEX BOLT- 1/2 X 1.5 NC GR5 PL	8
21	O.L.	HEX NUT - 3/4NC GR5 PL	1
22	O.L.	LOCK WASHER- 3/4 PL	1
23	O.L.	HEX BOLT- 5/8 X 1.75 NC GR5 PL	4
24	O.L.	HEX BOLT- 5/8 X 2 NC GR5 PL	24
25	O.L.	LOCKWASHER - 1/2" PL	4
26	523136	CASTER LOCK BAR	2
27	523173	PIN - 1 X 3-5/16"	1
28	O.L.	FLAT WASHER- 1 PL	2
29	O.L.	HAIR PIN - 3/16 x 3 5/8	1
30	O.L.	3/16 X 1-1/2" COTTER PIN	2
31	O.L.	HEX BOLT- 5/8 X 2.5 NC GR5 PL	4
32	O.L.	HEX NUT - 1/2NC GR5 PL	4

O.L. - OBTAIN LOCALLY

2.2 Wing Frame

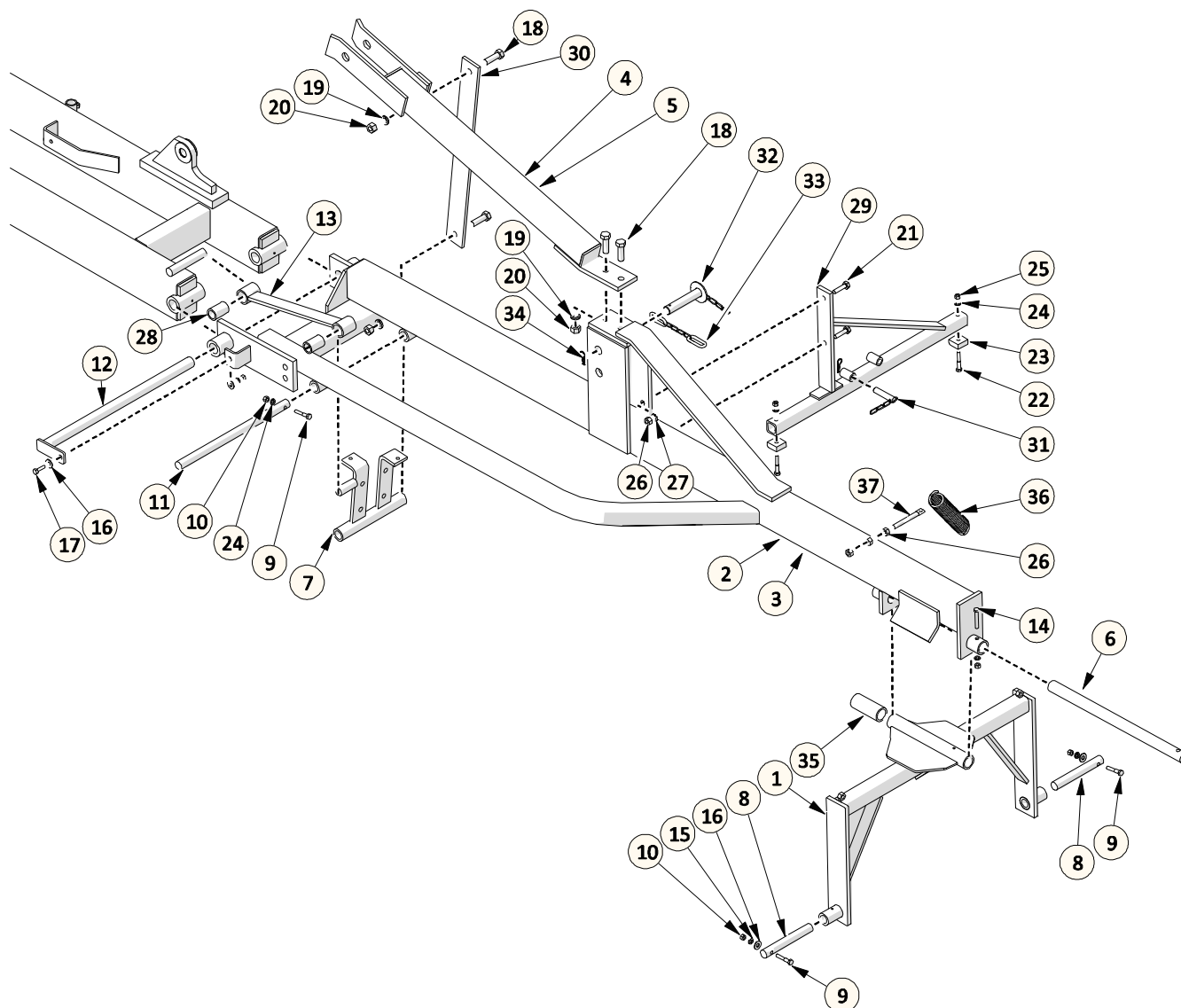

ITEM	PART #	DESCRIPTION	QTY
1	521422	DECK SWIVEL	1
2	523034	WING FRAME -LH (SHOWN)	1
3	523033	WING FRAME -RH	1
4	523024	WING LOCK ARM -LH (SHOWN)	1
5	523019	WING LOCK ARM - RH	1
6	523153	SWIVEL PIN	1
7	523065	PTO PIVOT	1
8	521346	WING DECK PIN - LONG	2
9	O.L.	HEX BOLT- 3/8 X 2 NC GR5 PL	3
10	O.L.	HEX NUT - 3/8NC GR5 PL	5
11	523154	PTO PIVOT PIN	1
12	523155	WING PIN	1
13	523058	PTO SWIVEL LINK W/ BUSHINGS	1
14	O.L.	HEX BOLT- 3/8 X 2.25 NC GR5 PL	1
15	O.L.	LOCK WASHER- 3/8 PL	3
16	O.L.	FLAT WASHER- 3/8 PL	4
17	O.L.	HEX BOLT - 3/8 x 1.25 NC GR5 PL	1
18	O.L.	HEX BOLT- 5/8 X 2 NC GR5 PL	4
19	O.L.	LOCK WASHER- 5/8 PL	4

ITEM	PART #	DESCRIPTION	QTY
20	O.L.	HEX NUT - 5/8NC GR5 PL	4
21	O.L.	HEX BOLT- 1/2 X 1.75 NC GR5 PL	2
22	O.L.	HEX BOLT- 3/8 X 2.25 NC GR5 PL	2
23	600512	BUMPER KIT (4 PCS) W/HARDWARE	1
24	O.L.	LOCK WASHER- 3/8 PL	4
25	O.L.	HEX NUT - 3/8NC GR5 PL	2
26	O.L.	HEX NUT - 1/2NC GR5 PL	4
27	O.L.	LOCK WASHER- 1/2 PL	2
28	523502	WEAR BUSHING KIT (4 PCS)	1
29	523035	DECK LOCKOUT BRACKET	1
30	523011	WING LOCK BRACE	1
31	523132	DECK LOCK PIN W/ CHAIN	1
32	523138	WING LOCK PIN	1
33	115007	WING SAFETY CHAIN	1
34	O.L.	HAIR PIN - 3/16 X 3-5/8	2
35	523151	SWIVEL SPACER	1
36	521431	SPRING	1
37	521102	SPADE BOLT W/NUT	1

O.L. - OBTAIN LOCALLY

2.3 Connecting Frame

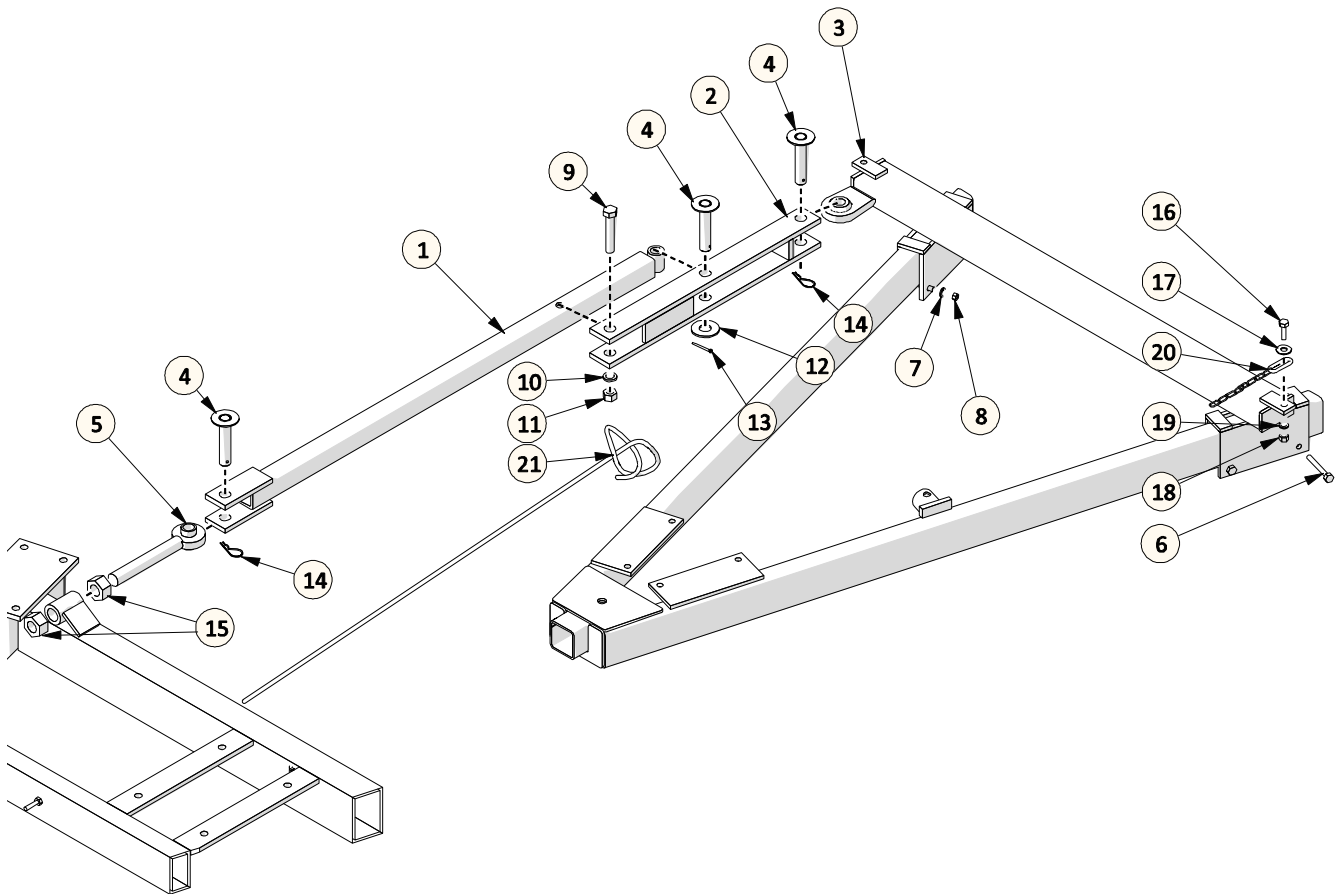

ITEM	PART #	DESCRIPTION	QTY
1	523041	CONNECTING TUBE	1
2	523045	CONNECTING BARS	1
3	523050	CONNECTING FRAME	1
4	523030	PIN - LINK & HITCH	3
5	213011	TOP LINK	1
6	O.L.	HEX BOLT- 1/2 X 3.5 NC GR5 PL	4
7	O.L.	LOCK WASHER- 1/2 PL	4
8	O.L.	HEX LOCK NUT - 3/8 NC GR5 UPL	4
9	O.L.	HEX BOLT- 3/4 X 4 NC GR5 PL	1
10	O.L.	LOCK WASHER- 3/4 PL	1
11	O.L.	HEX NUT - 3/4NC GR5 PL	1
12	O.L.	FLAT WASHER- 1 PL	1
13	O.L.	COTTER PIN - 3/16" x 1-1/2"	1
14	O.L.	HAIR PIN - 3/16 x 3 5/8	2
15	O.L.	HEX NUT - 1-1/4NC GR5 PL	1
16	O.L.	HEX BOLT- 1/2 X 1.5 NC GR5 PL	1
17	O.L.	FLAT WASHER- 1/2 PL	1
18	O.L.	HEX NUT - 1/2NC GR5 PL	1
19	O.L.	LOCK WASHER- 1/2 PL	1
20	115008	SAFETY CONNECTING CHAIN	1
21	119003	PULL ROPE	1

O.L. - OBTAIN LOCALLY

2.4 Caster Arm Assemblies

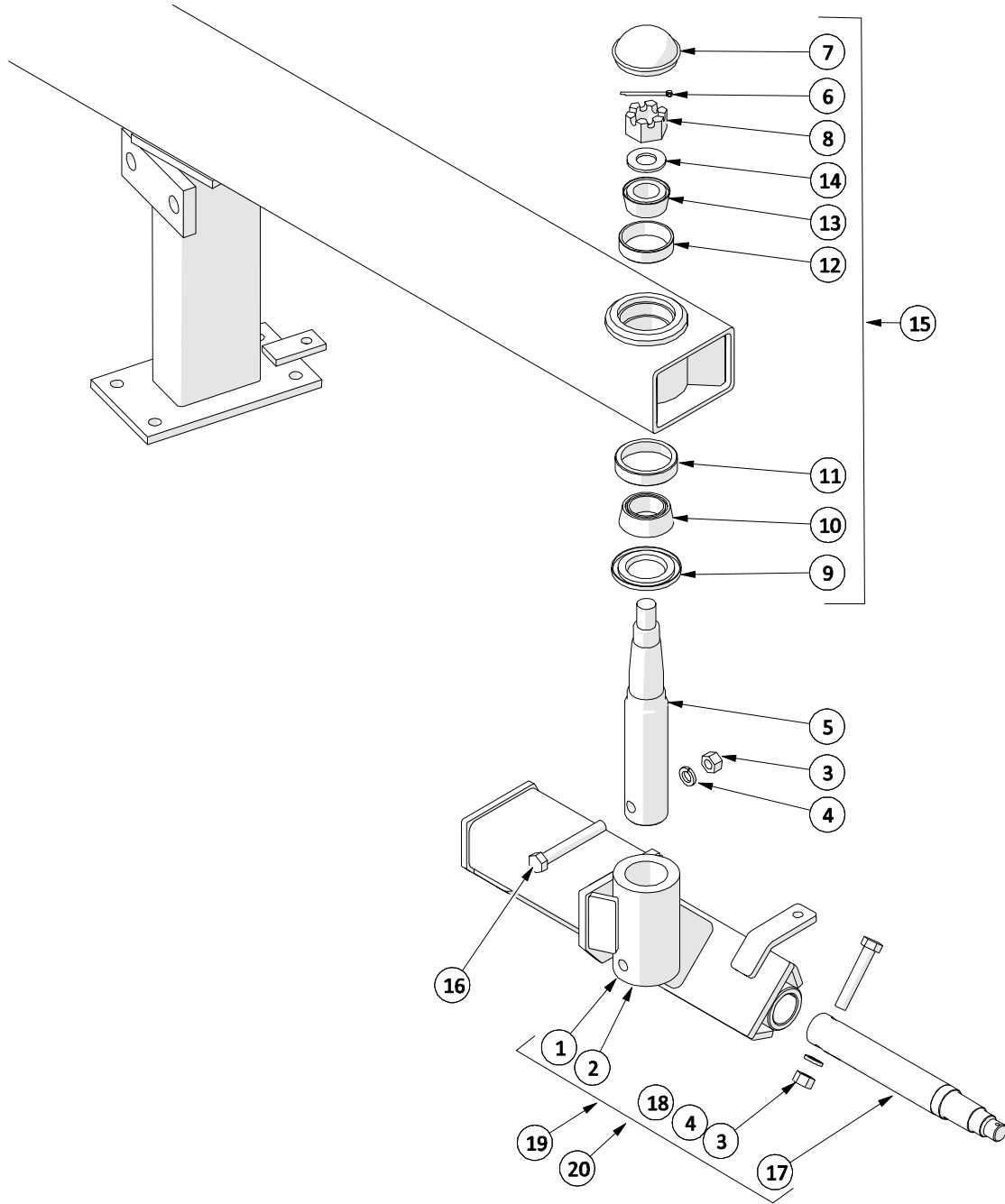

ITEM	PART #	DESCRIPTION	QTY
1	SEE ITEM 19	CASTER ARM - R.H. (NOT SHOWN)	1
2	SEE ITEM 20	CASTER ARM - L.H. (SHOWN)	1
3	O.L.	HEX NUT - 5/8NC GR	2
4	O.L.	LOCK WASHER- 5/8 PL	2
5	230020	SPINDLE - PM36	2
6	O.L.	3/16 X 2-1/2" COTTER PIN	1
7	230024	DUST CAP	2
8	305616	HEX NUT - SLOTTED (2 PCS)	1
9	-	SEAL - 6000# HUB	1
10	213005	BEARING - INNER 6000#	1
11	-	BEARING CUP - INNER 6000#	1

ITEM	PART #	DESCRIPTION	QTY
12	-	BEARING CUP - OUTER 6000#	1
13	213006	BEARING - OUTER 6000#	1
14	-	WASHER - 1.06 X 2.03	1
15	230023	HUB REBUILD KIT - 6000#	1
16	O.L.	HEX BOLT- 5/8 X 4.5 NC GR8 PL	1
17	523219	PM36 CASTOR AXLE	2
18	O.L.	HEX BOLT- 5/8 X 3.5 NC GR5 PL	1
19	523210*	PM CASTER ARM KIT - RH	1
20	523208*	PM CASTER ARM KIT - LH (SHOWN)	1

O.L. - OBTAIN LOCALLY

*REPLACES ALL PREVIOUS 523170 & 523171 WELDED CASTER ARMS

2.5 Tire Assemblies

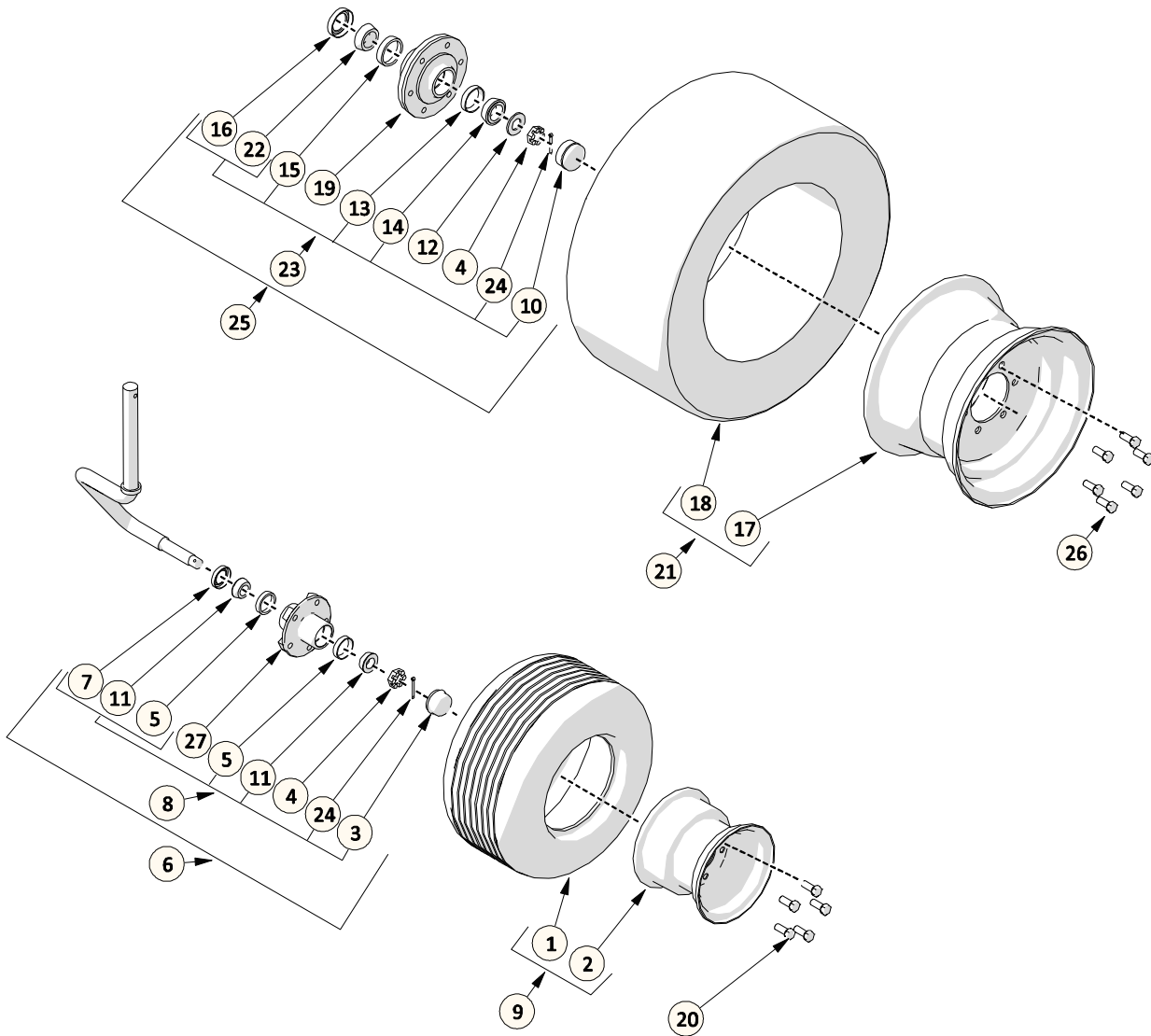

ITEM	PART #	DESCRIPTION	QTY
1	521052	TIRE - 18 X 9.5 RIBBED	1
2	521398	RIM - 8 X 7	1
3	521748	DUST CAP	1
4	521747	HEX NUT - SLOTTED (2 PCS)	2
5	-	BEARING RACE	2
6	521405	B/T HUB ASSEMBLY	2
7	521493	GREASE SEAL	1
8	521500	BEARING KIT - CASTOR	2
9	521028	TIRE & RIM - 18 - 9.50 X 8	2
10	521762	DUST CAP	1
11	-	BEARING TAPERED	2
12	521761	WASHER (2 PCS)	1
13	-	BEARING RACE - OUTER	1
14	-	BEARING - OUTER	1

ITEM	PART #	DESCRIPTION	QTY
15	-	BEARING RACE - INNER	1
16	521741	GREASE SEAL	1
17	521084R	RIM - 15 X 10	1
18	O.L.	TIRE - P275/60 SR15	1
19	-	HUB ASSEMBLY	1
20	521093	WHEEL STUD KIT - 1/2 NF (6 PCS)	1
21	521084	TIRE & RIM - P275/60 SR15	1
22	-	BEARING - INSIDE	1
23	521046	BEARING KIT - WHEEL	1
24	521752	COTTER PIN (6 PCS)	2
25	521085	HUB ASSEMBLY	1
26	521083	WHEEL STUD KIT (6PCS)	1
27	-	HUB ASSEMBLY	1

O.L. - OBTAIN LOCALLY

3 HYDRAULICS

3.1 Hydraulics

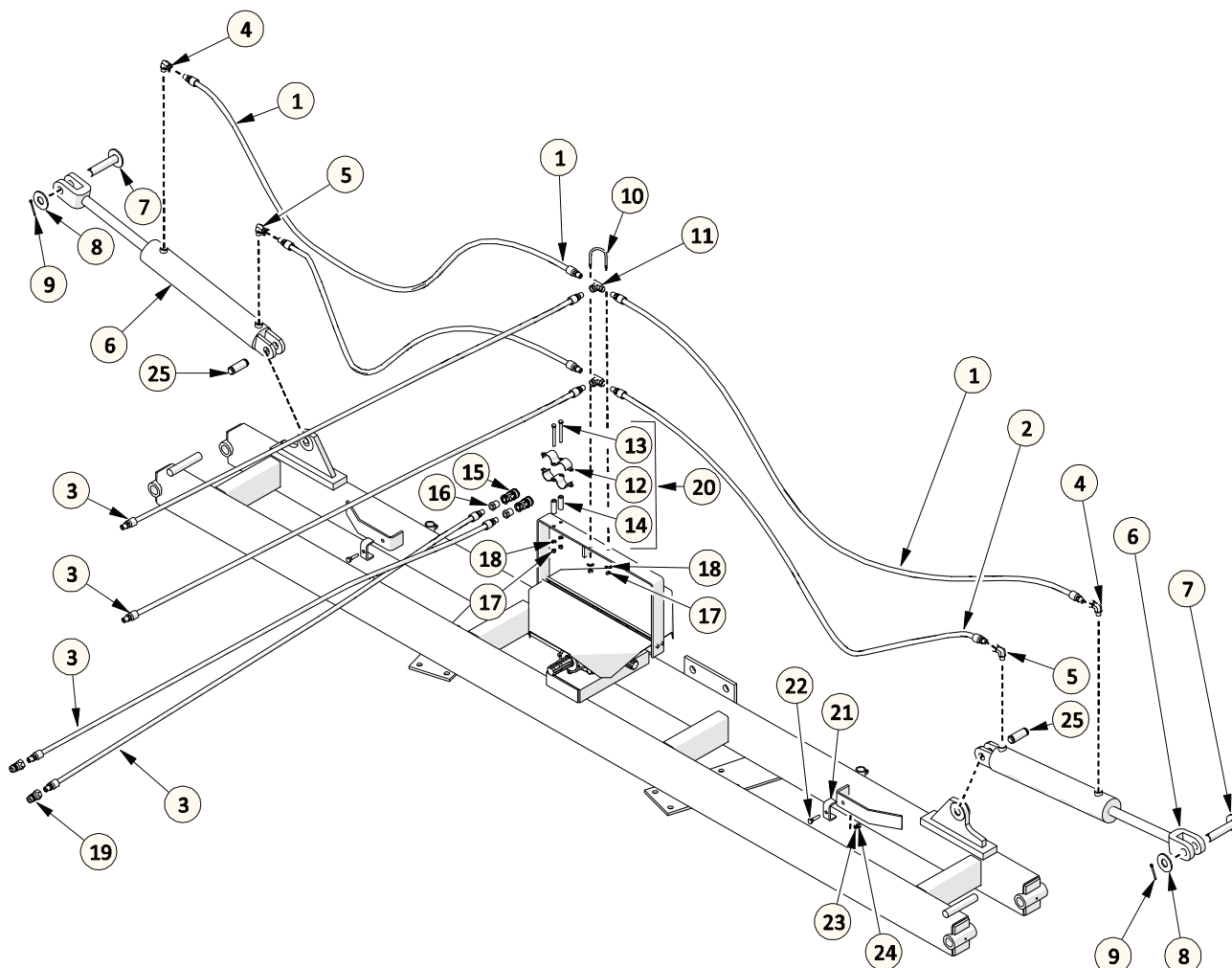

ITEM	PART #	DESCRIPTION	QTY
1	221008	HYDRAULIC HOSE - 98"	2
2	221007	HYDRAULIC HOSE - 72"	2
3	521413	HYDRAULIC HOSE - 152"	4
4	222012	ADAPTOR - 90 DEGREE RESTRICTOR	2
5	222013	ADAPTOR - 90 DEGREE	2
6	220004	HYDRAULIC CYLINDER - WING	2
7	521103	WING CYLINDER PIN	2
8	O.L.	FLAT WASHER- 1 PL	2
9	O.L.	COTTER PIN - 3/16" X 1.50"	2
10	304202	U BOLT	1
11	521770	HYDRAULIC TEE	2
12	-	BREAKAWAY HOSE CLAMP	2
13	O.L.	HEX BOLT- 5/16 X 2.75 NC GR5 PL	2

ITEM	PART #	DESCRIPTION	QTY
14	600295	BUSHING	2
15	222010	HOSE END KIT (2 PCS)	2
16	222011	HEX BUSHING ADAPTER	2
17	O.L.	HEX NUT - 5/16NC GR5 PL	4
18	O.L.	LOCKWASHER - 5/16" PL	4
19	222006	HOSE END KIT (2 PCS)	1
20	229005	COUPLER HOLDER KIT	1
21	521051	HYDRAULIC HOSE CLAMP	2
22	O.L.	HEX BOLT- 3/8 X 1.5 NC GR5 UPL	2
23	O.L.	LOCK WASHER- 3/8 PL	2
24	O.L.	HEX NUT - 3/8NC GR5 PL	2
25	521345	PIN - 1" W/CLIPS	2

O.L. - OBTAIN LOCALLY

4 DRIVELINE

4.1 Driveline

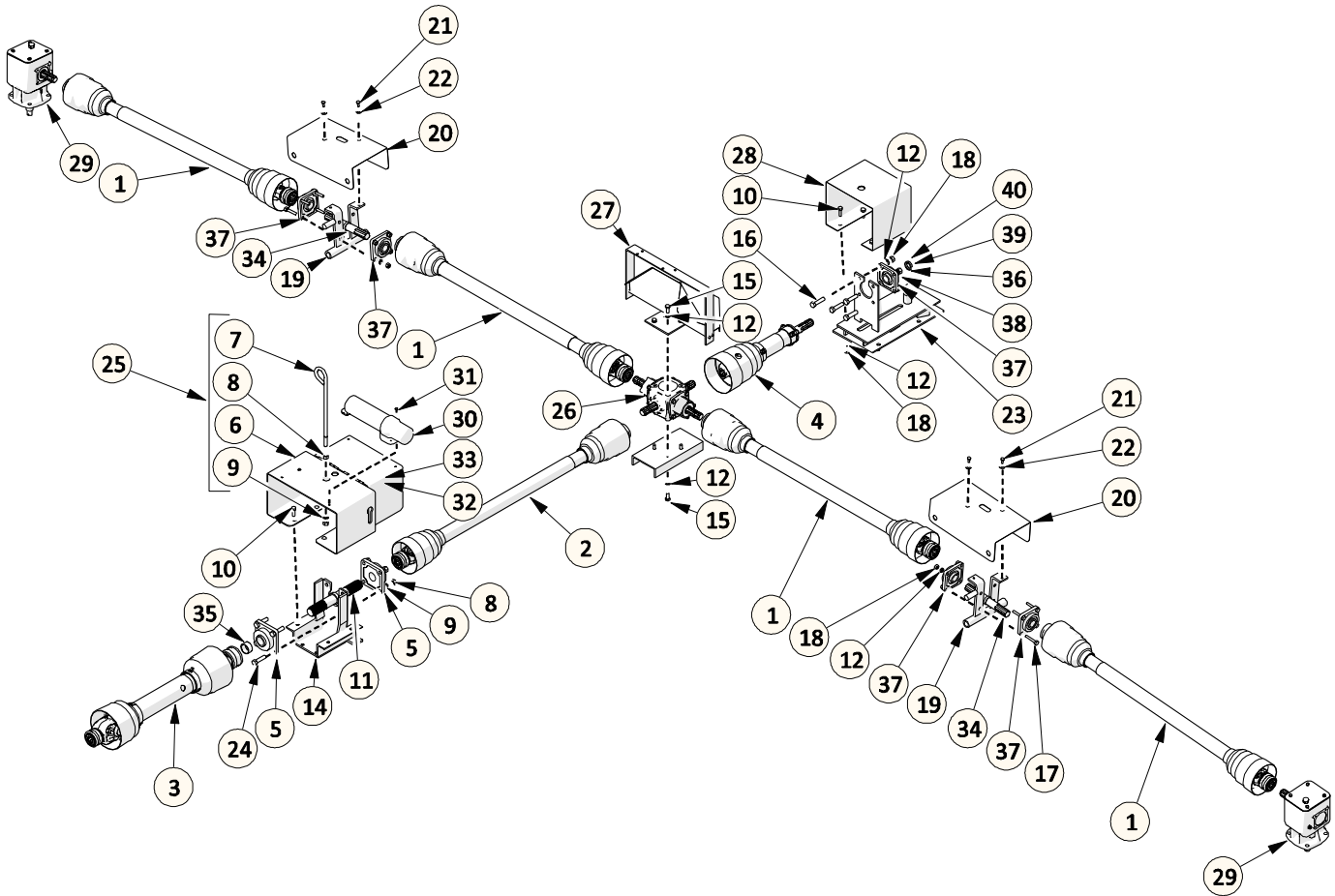

ITEM	PART #	DESCRIPTION	QTY
1	521474	DECK PTO SHAFT	4
2	210070	INTERMEDIATE PTO SHAFT	1
3	210023	INPUT PTO SHAFT	1
4	210019	INTERMEDIATE PTO SHAFT - SHORT	1
5	213015	4 BOLT FLANGE BEARING	2
6	523190	HOSE SUPPORT ASSEMBLY	1
7	522413	HOSE GUIDE - C/W HARDWARE	1
8	O.L.	HEX NUT - 5/8NC GR5 PL	6
9	O.L.	LOCK WASHER- 5/8 PL	5
10	O.L.	HEX BOLT- 1/2 X 1.5 NC GR5 PL	8
11	210071	SPLINED SHAFT	1
12	-	LOCKWASHER - #12 PL (SEE ITEM 37)	22
13	521764	METRIC BOLT & LOCKWASHER KIT (8 PCS)	1
14	523182	FRONT PTO SUPPORT	1
15	-	HEX BOLT - M12 X 30GR 8.8 (SEE ITEM 13)	8
16	O.L.	HEX BOLT- 1/2 X 1.75 NC GR5 PL	4
17	O.L.	HEX BOLT- 1/2 X 2.5 NC GR5 PL	8
18	O.L.	HEX NUT - 1/2NC GR5 PL	14
19	523065	PTO PIVOT	2
20	523037	WING PTO SHIELD	2
21	O.L.	HEX BOLT - 3/8 x .75 NC GR5 PL	4

ITEM	PART #	DESCRIPTION	QTY
22	O.L.	FLAT WASHER- 3/8 PL	4
23	523061	REAR PTO SUPPORT	1
24	O.L.	HEX BOLT- 5/8 X 2.5 NC GR5 PL	4
25	522208	HOSE SUPPORT & SHIELD - COMPLETE	1
26	521497	4 SHAFT GEARBOX	1
27	523085	MAIN GEAR BOX SHIELD	1
28	523067	SHIELD - REAR JACKSHAFT	1
29	521432	DECK GEARBOX	2
30	120519	MANUAL HOLDER TUBE	1
31	O.L.	CARR BOLT - 1/4 X 3/4 NC GR5 PL	2
32	O.L.	HEX NUT - 1/4NC GR5 PL	2
33	O.L.	LOCK WASHER- 1/4 PL	2
34	210022	PTO STUB SHAFT	2
35	523165	FRONT PTO SPACER - PM36	1
36	523169	REAR PTO SPACER-RED UP TO S#1336228	1
37	521323	FLANGE BEARING - UP TO S#1336228	5
38	213021	FLANGE BEARING - S#1336228 & UP	1
39	523205	REAR PTO SPACER-WEASLER-S#1336228 AND UP	1
40	523203	REAR PTO SPACER-COMER-S#1336228 AND UP	1

O.L. - OBTAIN LOCALLY

4.2 Input PTO Shaft

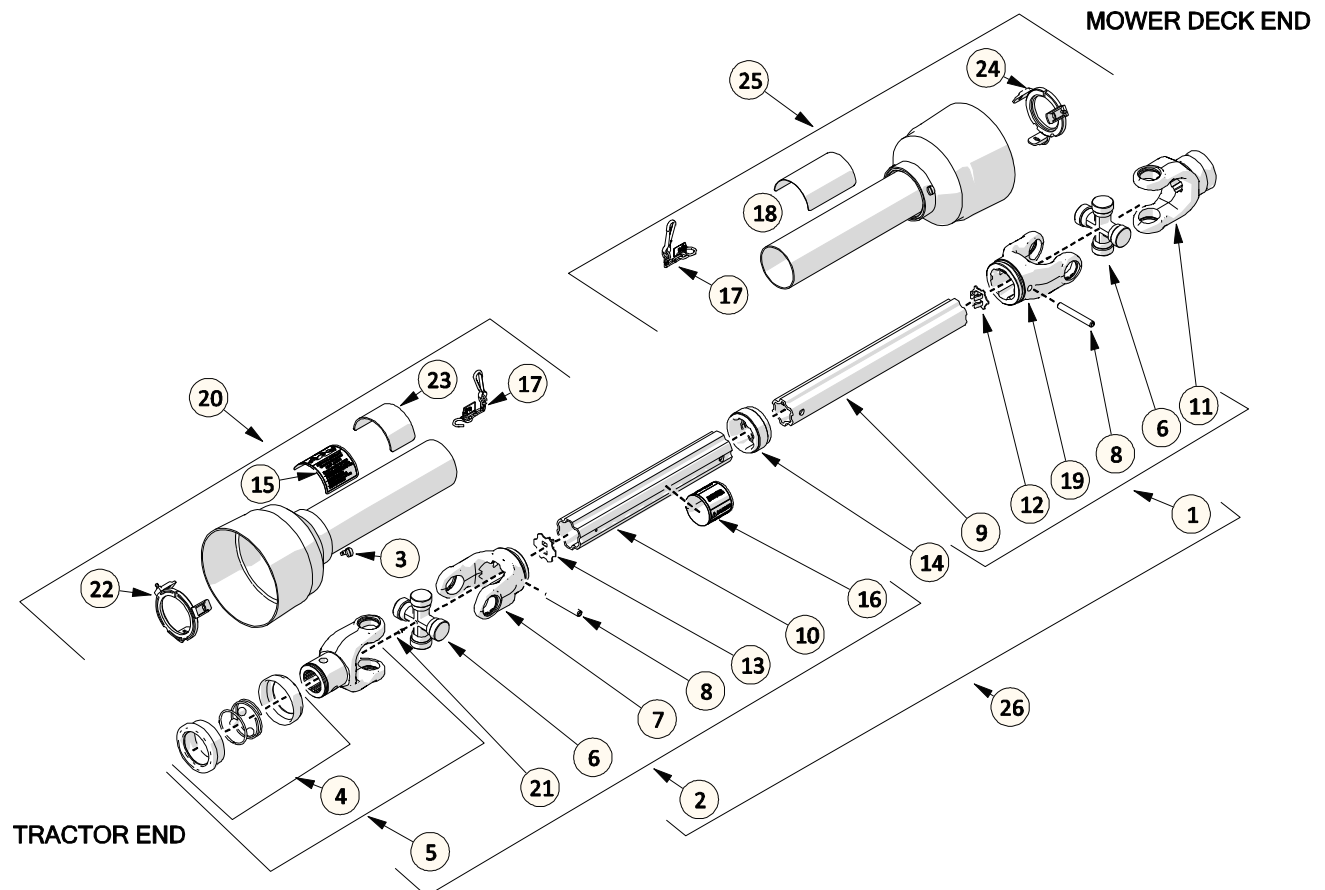

ITEM	PART #	DESCRIPTION	QTY
1	210033	PTO 1/2 SHAFT - MALE W/SHIELDING	1
2	210032	PTO 1/2 SHAFT - FEMALE W/SHIELDING	1
3	521463	PLASTIC SHIELD BOLT (6 PCS)	1
4	210017	SLIDE COLLAR KIT-METALLIC	1
5	210025	YOKE - 1-3/8	1
6	210026	UNIVERSAL JOINT KIT	2
7	210027	YOKE - TUBE YOKE	1
8	302605	SPLIT PIN	2
9	210029	INNER TUBE	1
10	210028	OUTER TUBE	1
11	210055	YOKE - 1-3/4"	1
12	210060	INNER CLOSING CAP	1
13	210059	OUTER CLOSING CAP	1
14	210056	WIPER	1

ITEM	PART #	DESCRIPTION	QTY
15	521455	DECAL - DANGER - OUTER SHIELD	1
16	521451	DECAL - DANGER - OUTER TUBE	1
17	521467	SAFETY CHAIN	2
18	209118	DECAL - INDICATOR - PM36 INPUT PTO	1
19	210030	YOKE - INNER TUBE	1
20	210034	1/2 PTO SHIELD - FEMALE W/LABEL	1
21	521821	GREASE FITTING - M6 STRAIGHT	2
22	210058	COLLAR - OUTER TUBE	1
23	209114	DECAL - IMPORTANT GREASING	1
24	210057	COLLAR - INNER TUBE	1
25	210035	1/2 PTO SHIELD - MALE	1
26	210023	INPUT PTO SHAFT - COMPLETE (W/SHIELDS)	1

4.3 Intermediate PTO Shaft

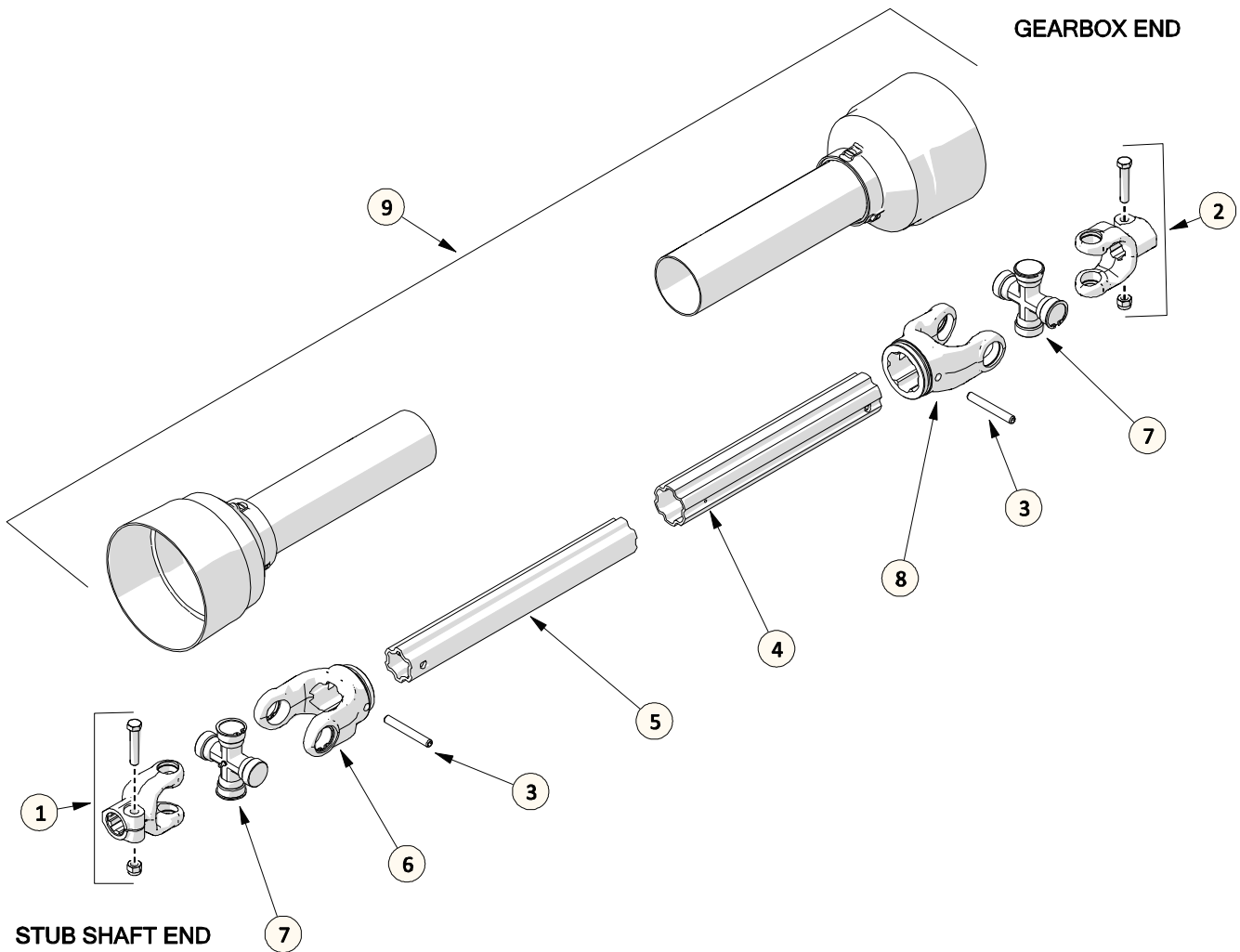

ITEM	PART #	DESCRIPTION	QTY
1	210074	YOKE - 1-3/4 W/BOLT & NUT	1
2	210072	YOKE - 1-3/8 W/BOLT & NUT	1
3	521450	ROLL PIN	2
4	210076	OUTER TUBE	1
5	210077	INNER TUBE	1
6	210073	YOKE INNER TUBE	1
7	210026	UNIVERSAL JOINT KIT	2
8	210039	YOKE - OUTER TUBE	1
9	210075	COMPLETE GUARD KIT	1
10	210070	COMPLETE INTERMEDIATE SHAFT	1

4.4 Deck PTO Shaft

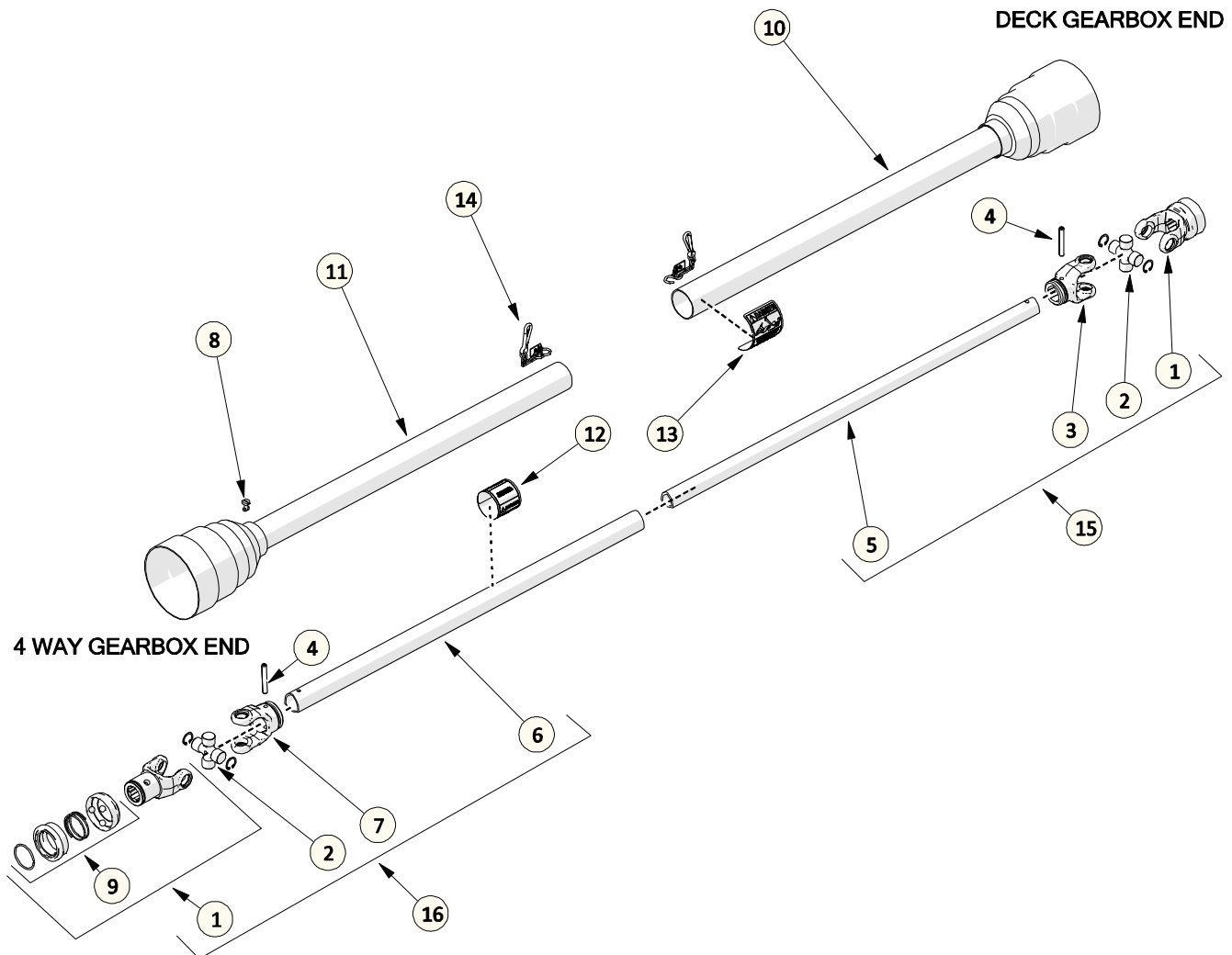

ITEM	PART #	DESCRIPTION	QTY
1	521800	QD. YOKE 1-3/8" 6 SPLINE	2
2	521801	CROSS AND BEARING KIT	2
3	521805	INNER TUBE YOKE	1
4	521781	ROLL PIN - 8MM X 55MM	2
5	529204	INNER TUBE	1
6	529202	OUTER TUBE	1
7	521802	YOKE - OUTER TUBE	1
8	521463	PLASTIC SHIELD BOLT - 6 PC KIT	1
9	210017	SLIDE COLLAR KIT - METALLIC	1
10	521473	PTO - 1/2 MALE SHIELD	1
11	521472	PTO - 1/2 F SHIELD - W/LABEL	1
12	521451	DECAL DANGER - OUTER TUBE	1
13	521455	DECAL - DANGER - OUTER SHIELD	1
14	521467	SAFETY CHAIN	2
15	521471	PTO - 1/2 M SHAFT W/SHIELD	1
16	521470	PTO 1/2 F SHAFT W/SHIELD	1
17	521474	PTO SHAFT - TD92 DECK - COMPLETE	1

4.5 Rear Output PTO Shaft

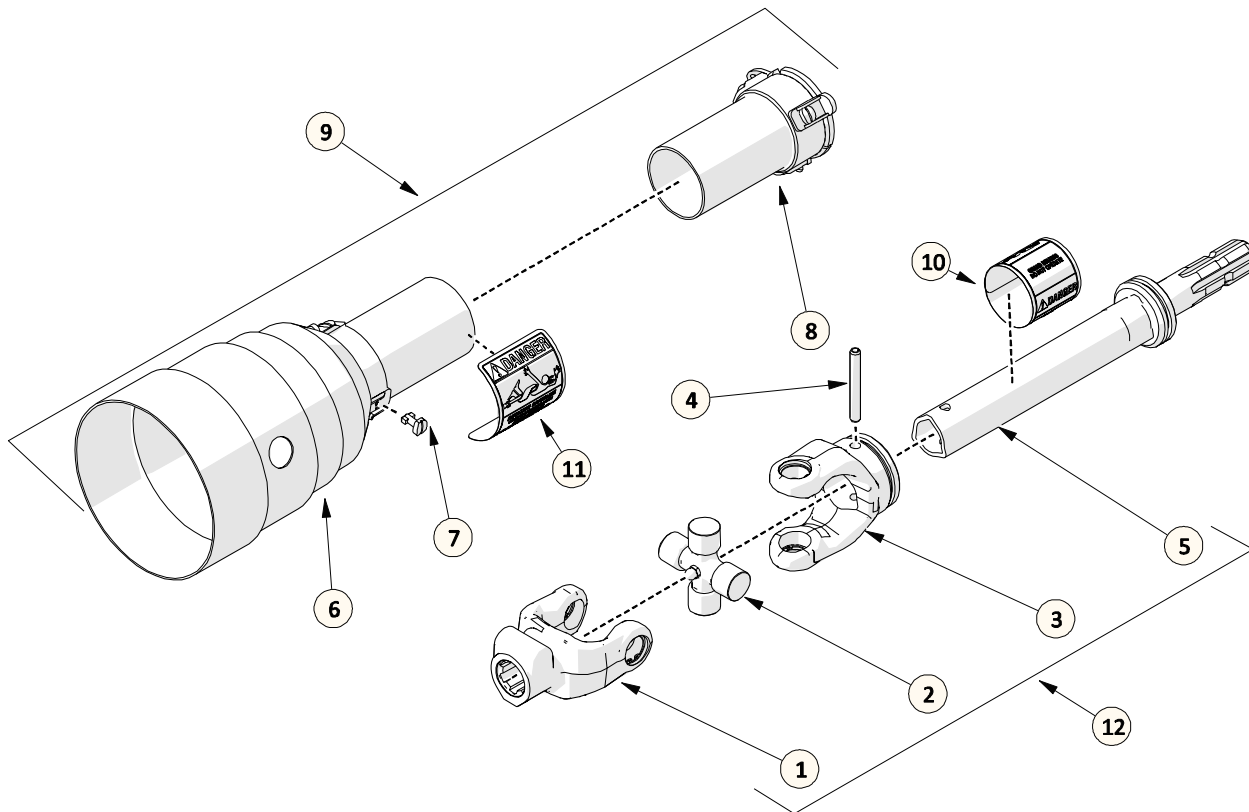

ITEM	PART #	DESCRIPTION	QTY
1	210011	YOKE - SPLINED	1
2	521460	UNIVERSAL JOINT KIT	1
3	210014	YOKE - OUTER	1
4	521450	ROLL PIN - OUTER TUBE	1
5	210036	OUTER TUBE W/SPLINE	1
6	-	SHIELD - FEMALE	1
7	521463	PLASTIC SHIELD BOLT 6 PC KIT	1
8	-	SHIELD - MALE	1
9	210041	PTO SHIELD KIT	1
10	521451	DECAL - DANGER	1
11	521455	DECAL - DANGER - OUTER SHIELD	1
12	210019	COMPLETE REAR OUTPUT SHAFT W/SHIELDS	1

4.6 Deck Gearbox

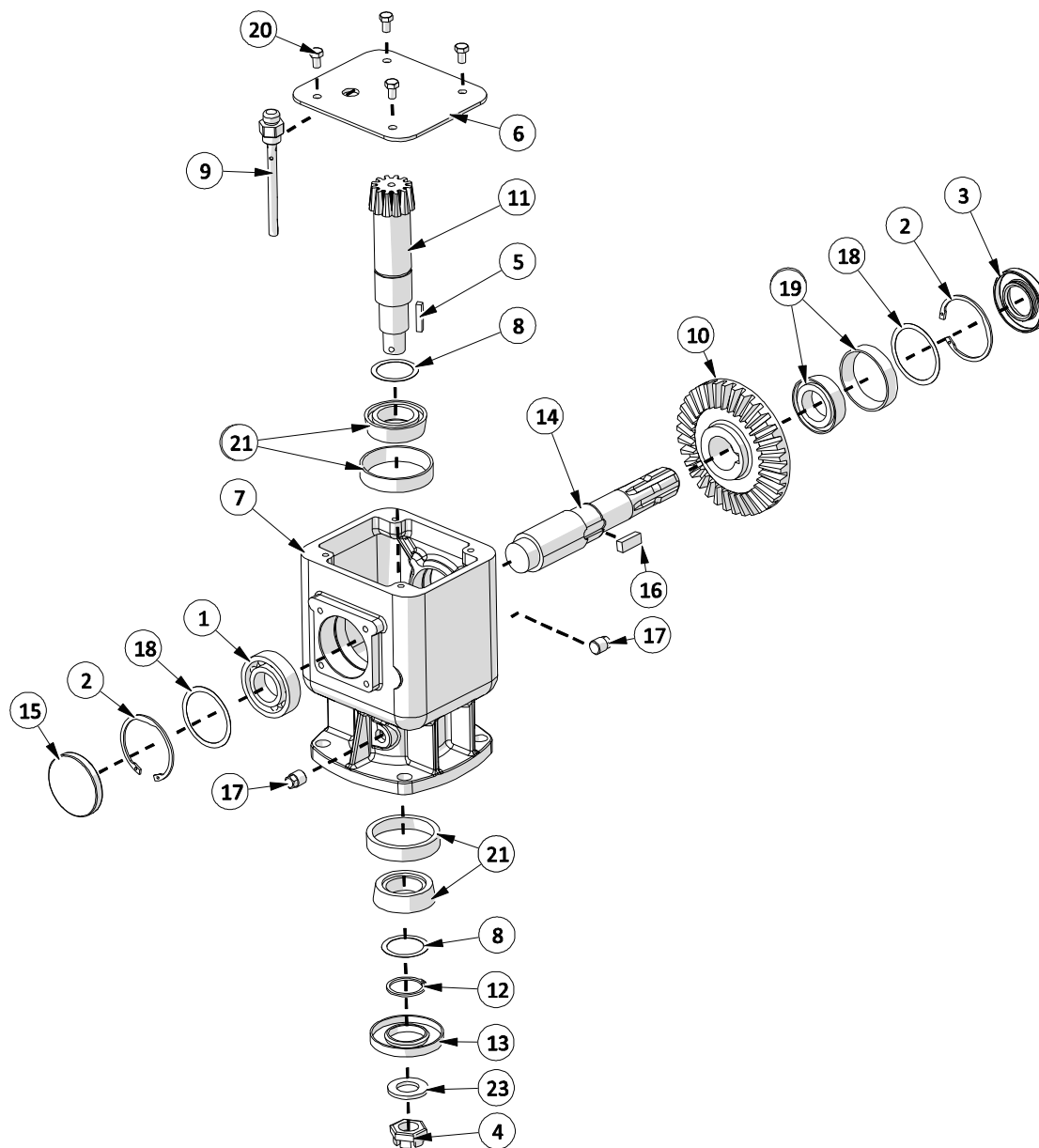

ITEM	PART #	DESCRIPTION	QTY
1	521116	BEARING	1
2	521126	SNAP RING - 3 PC KIT	2
3	521127	OIL SEAL	1
4	521130	CASTLE NUT - M24	1
5	521390	DECK GEARBOX KEY (3 PCS)	1
6	521420	COVER PLATE	1
7	521428	CASING	1
8	521436	SHIM KIT (2 PCS)	2
9	521433	OIL LEVEL DIPSTICK	1
10	521434	GEAR	1
11	521435	PINION SHAFT	1
12	521439	SNAP RING - 3 PC KIT	1

ITEM	PART #	DESCRIPTION	QTY
13	521440	OIL SEAL	1
14	521441	INPUT SHAFT	1
15	521443	CAP	1
16	521444	KEY - 12 X 8 X 30	1
17	521482	HEX PIPE PLUG	2
18	521491	SHIM KIT	2
19	521362	BEARING - TAPERED ROLLER	1
20	521399	BOLT - M8 X 14 - 8.8	4
21	521442	BEARING - 30208	2
23	521129	WASHER KIT (3 PCS)	1
24	521432	GEAR BOX - DECK - COMPLETE	1

4.7 4 Way Gearbox

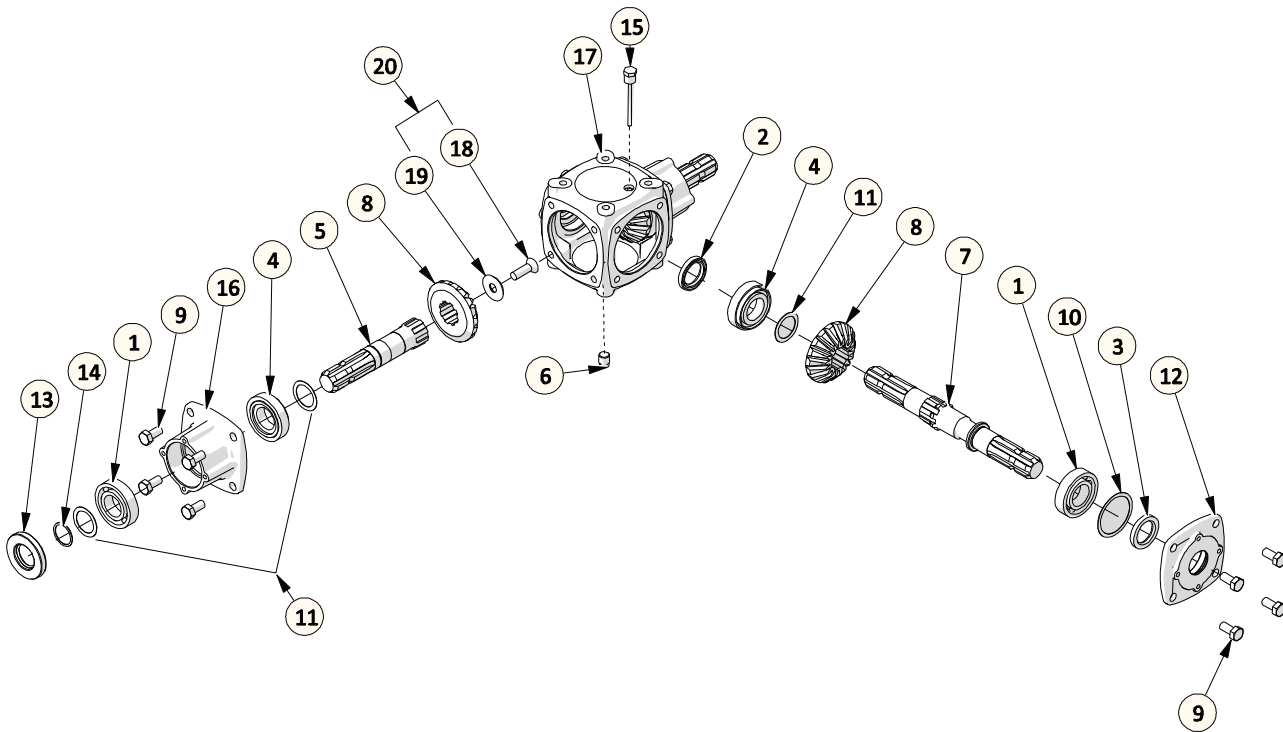

ITEM	PART #	DESCRIPTION	QTY
1	521116	BEARING - 6207	3
2	521120	OIL SEAL	1
3	521120	OIL SEAL	1
4	521362	BEARING - TAPER ROLLER - 7207E	3
5	521481	STUB EXTENSION SHAFT	2
6	521482	HEX PIPE PLUG	1
7	521486	THRU SHAFT	1
8	521487	GEAR (Z18 M5)	3
9	521488	BOLT - M12 X 25 - 8.8 KIT (6 PCS)	2
10	521491	SHIM KIT (3 PCS)	1
11	521794	SHIM KIT - 3 PCS	1
12	521797	COVER	1
13	521127	OIL SEAL	2
14	521137	SNAP RING	1
15	521489	DIPSTICK	1
16	521796	EXTENSION HOUSING	2
17	521483	HOUSING	1
18	-	HEX COUNTERSUNK BOLT - M12 X 40	2
19	-	WASHER	2
20	522426	GEARBOX SHAFT BOLT KIT	1

5 DECALS

5.1 Safety

If decals become faded, damaged or lost, replace immediately. Order according to corresponding part number below. Complete decal kits are also available.

PM36 Decal Kit – 209106



209175
DECAL – GENREAL SAFETY

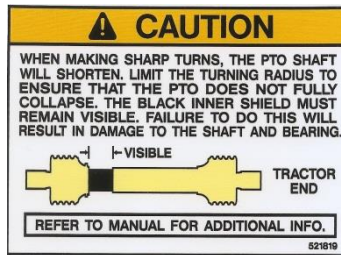

521819
DECAL - CAUTION



209113
DECAL- REPLACE SHIELDS



209173
ROTATIING BLADE DANGER



209115
DECAL – OEM PARTS



521817
DECAL – PROGRESSIVE TURF

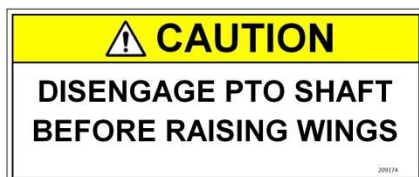

209174
DECAL – DISENGAGE PTO



209114
DECAL – IMPORTANT GREASING

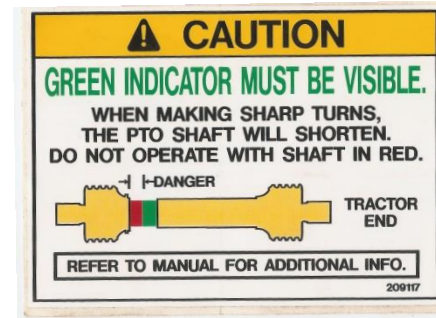

209117
DECAL – CAUTION – PM36 ON TRACTOR

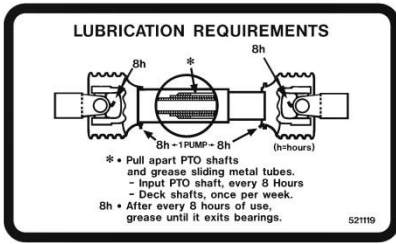

521119
8HR DECAL- PTO GREASE

PROGRESSIVE
PRO-MAX 36

209119
PM36 DECK SIDE DECAL

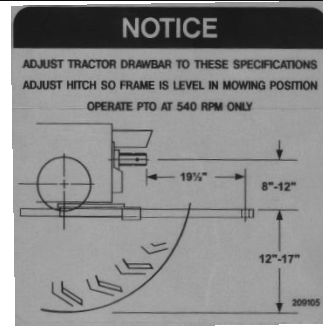

209105
DECAL - NOTICE



209118
DECAL - INDICATOR - PM36 INPUT



209112
DECAL - "PRO-MAX 36"



521451
DECAL - OUTER TUBE



521455
DECAL - OUTER SHIELD



GREASE POINT DECAL
(521014)

5.2 General Info