

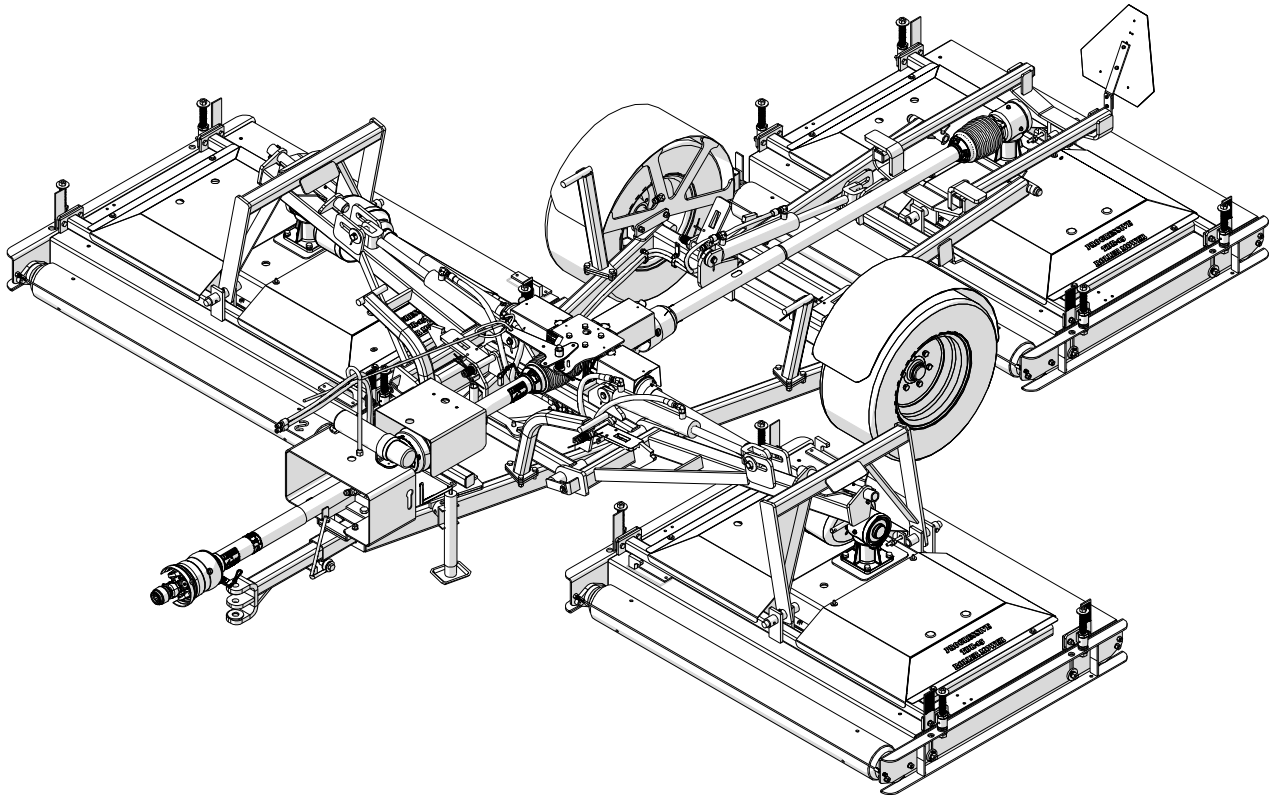

Operator's Manual  
and Parts List  
**TDR-15 TRI-DECK**

**Roller Rotary Finishing Mower**  
Serial No. 1315121 and up



PROGRESSIVE TURF EQUIPMENT INC.  
137 WEST WILLIAM STREET  
SEAFORTH, ONTARIO  
CANADA N0K 1W0

PHONE: 519-527-1080  
TOLL FREE: 800 668-8873  
ISSUE DATE: July 2014

SERIAL # \_\_\_\_\_  
WEB: [www.progressiveturfequip.com](http://www.progressiveturfequip.com)

P.N.120518



**DANGER!**

Si No Lee Ingles, Pida Ayuda a Alguien Que Se Lo Lea  
Para Que le Traduzca Las Medidas de Seguridad



# DECLARATION OF CONFORMITY

According to Annex 11 A of the European Community Regulation for Machines

We, Progressive Turf Equipment Inc. 137 West William Street, Box 940, Seaforth Ontario, Canada declare under our sole responsibility that:

## Progressive Rotary Finishing Mowers

<u>Models:</u>	<u>Part Number</u>	<u>Description</u>
TD65-2	526512D	3.66m Tri-Deck Finishing Mower
TD65	526515D	4.72m Tri-Deck Finishing Mower
TD92	529222E	6.70m Tri-Deck Finishing Mower
PF-120	601205D	3.05m Pro-Flex Contour Mower
PFR-120	601205RD	3.05m Pro-Flex Roller Contour Mower
PM-36	529236E	10.97m Pro-Max 36 Mowing System
TDR-22	526924E	6.70m Tri-Deck Roller Mower
TDR-15	528750D	4.72m Tri-Deck Roller Mower
TDR-12	528712D	3.65m Tri-Deck Roller Mower
SDR-65	531965C	165cm Three Point Hitch Roller Mower
SDR-90	531990C	228.6cm Three Point Hitch Roller Mower

are in conformity with Directive 98/37/EC of the European Parliament and of the Council of 22 June, 1998 on the approximation of the laws of the member states relating to Machinery.

The Technical Construction File is maintained at the corporate offices of Progressive Turf Equipment Inc. at the address listed above.

Dated at Seaforth, Ontario Canada the 28<sup>th</sup> day of February 2013.



Luke Janmaat  
President  
Progressive Turf Equipment Inc.



# **TABLE OF CONTENTS**

# **PAGE**

## **INTRODUCTION**

TO THE OWNER .....	3
GENERAL INFORMATION .....	4
WARRANTY .....	5
SPECIFICATIONS .....	6
SAFETY RULES .....	7
GENERAL SAFETY PRECAUTIONS .....	8
OPERATING EQUIPMENT SAFELY .....	9
MAINTENANCE SAFETY PRECAUTIONS .....	10
WELDING & GRINDING WORK PRECAUTIONS .....	11
SAFETY CHAINS .....	12
TRANSPORTING MOWER .....	12
TIRES .....	13
POWER TAKE OFF .....	13
SAFETY DECAL LOCATIONS .....	14
SAFETY DECALS .....	15
MAINTENANCE SAFETY .....	17

## **OPERATION OF THE MOWER**

DAILY CHECK LIST .....	18
HITCHING MOWER TO TRACTOR .....	19
LEVELING THE MOWER & PTO .....	20
INSTALLING PTO SHAFTS .....	21
CHECKING PTO LENGTH DURING TURNS .....	22
CUTTING HEIGHT ADJUSTMENT .....	23
Pro Lift-N-Turn SYSEM.....	24
GREASE COMPATIBILITY.....	25
LUBRICATION .....	26
GEARBOX OIL LEVEL .....	27

## **MAINTENANCE**

MOWER BLADE SERVICING .....	28
BLADE REMOVAL & INSTALLATION .....	29
BLADE SHARPENING .....	29
SPINDLE INSPECTION .....	30
SPINDLE ASSEMBLY REMOVAL .....	30
SPINDLE ASSEMBLY INSTALLATION .....	30
ASSEMBLY OF SPINDLES .....	31
“V” BELT ADJUSTMENT .....	32
“V” BELT TENSION .....	33
HYDRAULICS .....	33
TROUBLE SHOOTING .....	34

## **TO THE OWNER:**

Before you operate this mower, study this manual carefully. It has been prepared to help you do a better and safer job of maintaining your mower.

Use only genuine Progressive Turf Equipment Inc. replacement parts. Substitute parts will void the warranty and may not meet the standards required for safe and satisfactory operation of this equipment.

Blades are especially important. Their manufacturing process is a very exacting one and only a handful of blade producers are capable of this process. Always insist on purchasing and using OEM blades for your own protection and that of your employees.

## **GENERAL INFORMATION:**

The purpose of this manual is to assist the operator in maintaining and operating Progressive Turf Equipment mowers. Read it carefully. It furnishes information and instructions that will help you achieve years of dependable performance.

Some information may be general in nature due to unknown and varying conditions. However, through experience and these instructions, you should be able to develop operating procedures suitable to your particular situation.

Throughout this manual, references are made to right and left directions. These are determined by standing at the rear of the equipment and facing the direction of forward travel. Blade rotation is counter-clockwise as viewed from the top of the mower.

For quick reference, record the following information.

MODEL: \_\_\_\_\_

DATE PURCHASED: \_\_\_\_\_

SERIAL NUMBER: \_\_\_\_\_

For additional information, assistance during assembly, or operation of this mower, contact the dealer from whom the machine was purchased, or call Progressive Turf Equipment Inc.

PHONE: 519-527-1080    1-800-668-8873    FAX:519-527-2275

# WARRANTY POLICY

Progressive Turf Equipment Inc. warrants each new product to be free of defects in material and workmanship to the original purchaser. Warranty will be applicable, from the original date of purchase of the following new, unused current models:

**ProFlex 120, ProFlex 120R, TD65-2, TD65, TD92, Pro-Max 36, TDR-15, TDR-12, TDR-22, SDR-65, SDR-90**  
For all applications:

Basic Mower: 24 months  
Gear Boxes: 36 months

**To validate warranty, the Delivery and Warranty Registration form must be completely filled out & mailed to Progressive Turf Equipment Inc.**

This warranty will not cover any components which, in the opinion of the company, have been subjected to negligent use, alteration, and accident, damage due to lack of maintenance or use of wrong lubricants, or if parts supplied by others have been used in repairs of any product manufactured by Progressive Turf Equipment Inc. Items such as blades, belts, tires, wheels and batteries are considered consumable wear items and are excluded from Progressive Turf Equipment Inc.'s warranty coverage. Warranty coverage on these items is limited to what is provided by the OEM of the applicable part, if any.

Our obligation, in the event that any Progressive Turf Equipment Inc. product warranted, shall become defective or fail, will be limited to repairing or replacing free of charge, or provide labour and materials for the repair of, any defective part, subject to company approval. All defective parts must be retained for 60 days after applying for warranty consideration. This warranty will not provide for service calls to customer location or for transportation of equipment to dealer location if such servicing is required.

The sole liability of Progressive Turf Equipment Inc. under this warranty or any implied warranty, shall be limited as set forth herein. The customer agrees that Progressive Turf shall not in any event be obligated to reimburse, or pay the customer for any expense, loss or any direct, incidental or consequential damages to any person or property for any reason or caused by reason of Progressive Turf Equipment Inc., negligence, or otherwise in connection with the sale, delivery, installation, training or use of the equipment. The customer shall indemnify and hold Progressive Turf Equipment Inc. harmless against all such liability. PROGRESSIVE TURF EQUIPMENT INC. DISCLAIMS ANY EXPRESS (EXCEPT AS SET FORTH HEREIN) AND IMPLIED WARRANTIES WITH RESPECT TO THE GOODS INCLUDING, BUT NOT LIMITED TO, MERCHANTABILITY AND FITNESS FOR A PARTICULAR PURPOSE AND MAKES NO WARRANTY AS TO THE DESIGN, CAPABILITY, CAPACITY, OR SUITABILITY FOR USE OF THE GOODS.

Progressive Turf Equipment Inc. reserves the right to make improvements to the design or changes to the specifications at any time without prior notice or any obligation or duty to inform current owners or modify units previously sold.

This warranty is not subject to change or modification by anyone, including dealers, and no one is authorized to make any representation on behalf of Progressive Turf Equipment Inc.

**KEEP FOR YOUR RECORDS:** Purchaser should fill in the blanks below for his reference when buying repair parts and/or for proper machine identification when applying for warranty.

Model \_\_\_\_\_ Serial Number \_\_\_\_\_

Date Purchased \_\_\_\_\_ Dealer \_\_\_\_\_

**Read your Operator's Manual**

This warranty coverage supersedes all written warranties, effective November 1, 2012.

## TDR-15 MACHINE SPECIFICATIONS

Cutting Width	15 ½ feet	Deck Flexibility	25" up, 15 degree down
Cutting Height	½" to 4"	Numbers of wheels	2 on main frame
Recommended HP	30 Min – 50 Max	Mowing Capacity	MPH            2     4     6 Acres per hour 3.75   7.5   11.3
Hydraulics	Requires 1 double acting outlet, all hoses supplied to tractor	Paint Finish	Electrostatically painted with oven baked finish.
Transport Width	84"	SMV Sign	Located at back of mower for safety
Height	94".	Weight	Total 3725 lbs.
Length	14 ft.		
Ground Clearance	9 1/4" Cutting		

	<b>DECK</b>	<b>FRAME</b>
Drive	PTO shaft to right angle gear box driving 2-"B" section belts to 3 heavy-duty spindles.	"A" Frame    Hollow structural steel tubing with supports at high stress areas to achieve maximum strength.
Belt Adjustment	Easily made by loosening four bolts at gear box base and adjusting the slide plate forward or backward and retightening.	Wheels      5 bolt, 4 1/2" bolt circle Tires        2- 20.5X8-10ply Turf Tires
Deck Construction	3/16" steel plate formed and welded with supporting members at high stress areas to achieve maximum strength. Deck is 7" deep.	Hitch        4 positions, with height settings from 10-1/2" to 15". Safety chain with hook according to Dept. of Transport regulations.
Cutting Height	Easy and accessible screw mechanism. Infinite number of adjustments from ½" to 4"	Tongue Weight    Transport position – 800 lbs. Mowing position – 340 lbs.
Spindles	9 spindles, 3-30mm spindles per deck are each carried in 2 re-grease able ball bearings, which are housed, in a precision machined hub.	Cylinders    Rear deck: 1-2.5" x 12" double acting Wing deck: 2-2.5" x 12" double acting
Blade Support	3/4" x 2-1/2" x 8" long bar welded to spindle and machined. ½" bolts hold blade rigid to provide clean level cut.	Screw Jack      Side wind jack for easy hookup.
Blades	High lift, heat treated, alloy steel blades 5/16" x 2 ½" x 23" per deck. Tractor PTO – 540 RPM	Main Gear Box    4 shaft gear box with 1 3/8-6 spline shafts, delivering power to decks.
Speeds	Blades – 3040 RPM Blade Tip Speed 18,287 FPM	PTO Shafts      Deck Drive telescoping agricultural PTO Drive shafts, with proper safety shields. 1-3/8-6 spline quick-disconnect yokes on both ends.
Rollers	6" diameter with 1.88 wall thickness. Supported by (2) 1.25" two bolt ductile bearings	Input PTO... Category # 6. Deck PTO... Category # 4

## **SAFETY RULES**

All rotary mowers are potentially dangerous machines; this mower has been designed to minimize the safety risks to the operator, bystanders and property. This section of the Operator's Manual details a number of safety rules pertaining to the operation and maintenance of Progressive Turf Equipment mowers. In order to minimize risks and promote safety at all times, these rules must always be followed and obeyed.

Further safety rules and warning texts are given within the respective sections of this manual.

### **IMPORTANT!**

**When it comes to safety, nothing will ever replace a careful operator.**

It is imperative that the operator reads and understands all the safety information in this manual before proceeding. Failure to follow the instructions or heed the warnings could result in injury or death.

### **Proper care is your responsibility.**

The manufacturer cannot anticipate every possible circumstance that might involve a hazard. The hazard alerts in this publication and on the product, are therefore not all inclusive. If a tool, procedure, work method, or operating technique not specifically recommended by the manufacturer is used, it is your responsibility to ensure that it is safe for you and others. You should also ensure the machine will not be damaged or made unsafe by the operation, maintenance, or repair procedures you choose. Modifications or adaptations to the machine are not allowed.

Various jurisdictions have specific requirements for work zone safety. Know and adhere to your local requirements. Treat the instructions in this manual as minimum requirements for safe operation.

## **SAFETY ALERT SYMBOL**

This symbol appears at various points in the manual together with a signal word and warning text. **It means – Be alert! Your safety is involved.** This symbol is used throughout the manual to call attention to areas in which carelessness or failure to follow specific procedures may result in personal injury or component damage / malfunction or both.



## **HAZARD SERIOUSNESS LEVEL**

The following signal words are found throughout the manual together with the safety alert symbol to indicate the seriousness level of identified hazards. Their selection is based on the consequence of human interaction with a hazard.

**DANGER!** – Hazards or unsafe practices which **WILL** result in severe personal injury or death.



**WARNING!** – Hazards or unsafe practices that **COULD** result in severe personal or death.



**CAUTION!** – Hazards or unsafe practices that COULD result in minor personal injury or product or property damage.



## GENERAL SAFETY PRECAUTIONS

### **WARNING!**

- The operator of this machine must have sufficient knowledge and instructions in the care and operation of this mower and the power unit being used before he / she uses the machine. Do not allow unauthorized persons or children to operate the machine. Do not allow riders on the machine.
- It is the obligation of the operator to make sure that all guards and shields are in place on the machine. Safety decals must be in place and be readable – accidents may otherwise occur. Contact your dealer or the manufacturer for replacement manuals or decals.
- Never use a machine that does not have an operator’s manual available. Learn and understand the safety signs and symbols on the machine and the operator instructions before you begin to use the machine.
- Wear personal protective equipment. Know and use the protective equipment that is to be worn when operating or servicing the machine. Hard hats, protective glasses and face shields, protective shoes, gloves, reflector type vests, and ear protection are types of equipment that may be required. Prolonged exposure to loud noise can cause hearing damage.
- Never operate a mower while under the influence of drugs or alcohol. These make reflexes slow and put you and others in grave danger. Always make sure you have full concentration while mowing.
- Adhere strictly to all regulations at the worksite pertaining to the operation of this equipment.
- Always disengage power takeoff (PTO) when transporting or traveling between work sites.
- Be prepared for emergencies. Have a first aid kit, fire extinguisher and emergency contact information available at the work site.

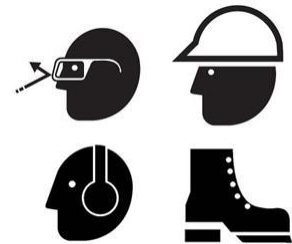

## POWER UNIT SAFETY

### **WARNING!**

- Operator must have sufficient knowledge in the care and operation of the power unit (tractor) before connecting power unit to mower.
- Power unit must be equipped with ROPS and seat belt. Foldable ROPS must be secured in the upright position. Follow recommendations of power unit manufacturer. Seat belt must be worn at all times.
- Power unit must be equipped with a 1-3/8” 6 spline 540 RPM PTO connection. Never use PTO adapters to connect implements. Never connect mower driveline to 1000 RPM PTO.

# OPERATING EQUIPMENT SAFELY

## **WARNING!**

- Never allow persons to stand between power unit and mower while backing power unit up to hitch the mower.
- Before hitching mower to power unit, place transmission in neutral, set park brake, and turn engine off. Remove the ignition key.
- Make sure locking collar on PTO shaft is properly locked. If the PTO shaft comes off during operation, personal injury or equipment damage could result.
- Always install safety chains properly when hitching mower to power unit.
- Tall grass can hide obstacles. Carefully walk the entire area to be mowed beforehand. Look for debris, rocks, tree limbs etc. that will damage or be thrown by the mower blades. Identify objects that cannot be removed. Set mower cutting height to avoid contact.
- Ensure that no bystanders are within 25 ft of mower when wing transport locks are released.
- Keep all bystanders well away from the machine when it is operating. Always maintain a safe operating distance of 300 ft from personnel, other equipment, or vehicles.
- Never operate the mower with deflectors or guards removed. Mower blades can cause small objects and debris to be thrown from under the mower deck at high speeds, up to 300 ft away. Objects ejected by the mower blades can cause severe injury.
- Never tamper with safety devices or operate the mower with them removed. Check proper operation regularly.
- Always disengage PTO, turn power unit off and remove key before dismounting, for any reason.
- Never place hands or feet under mower deck when the mower is operating or power unit engine is running.
- Disengage the PTO when crossing gravel areas or roadways.
- Disengage the PTO and turn power unit off upon striking any object. Inspect mower and repair any damage before continuing.
- If the equipment should start to vibrate abnormally during operation, stop the mower, shut down power unit, and immediately check for the cause. Excess vibration is generally an indication of a problem. Replace bent or damaged parts, do not attempt to straighten a bent blade.
- Use extreme care when operating on uneven terrain.
- Reduce speed when operating on slopes during wet conditions, especially when making sharp turns.
- Do not use the mower in limited visibility (e.g. at dusk, in fog, heavy rain etc.). Mow only in daylight or good artificial light.
- Disengage PTO and ensure blades are completely stopped before raising wings.

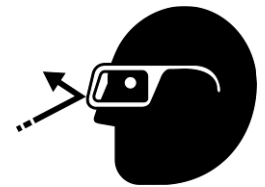

- Ensure transport locks are securely engaged before transporting mower with wings in raised position.
- Clean reflectors, Slow Moving Vehicle sign and lights before transporting. Use power unit hazard lights.
- Before disconnecting from power unit, always lower equipment to the ground, place controls in neutral, set park brake, turn engine off, and wait for all moving parts to stop. Relieve hydraulic pressure per power unit manufacturer's instructions.
- Ensure mower tongue jack is securely fastened to mower frame with supplied pin before removing hitch draw pin.

## MAINTENANCE SAFETY PRECAUTIONS

### **WARNING!**

- Never make adjustments or repairs with the engine running. Always disengage PTO, turn engine off, lower wings to cutting position and relieve hydraulic pressure before performing any maintenance.
- Observe and perform proper lock-out procedures for power unit if attached to mower during service.
- Keep nuts and bolts tight and properly torqued, especially blade attachment bolts. Check that all cotter pins are properly installed. Keep equipment in good condition.
- Keep mower free of grass, leaves, or other debris build-up.
- Never work on raised mower decks without safety locks in place.
- Periodically check condition of safety devices, guards, and deflectors. Replace only with manufacturer's recommended parts.
- Inspect and replace damaged blades. Use only original OEM parts. Blades can fail from poor maintenance practices.
- Handle mower blades carefully. They are sharp and can cut unprotected skin. Use caution and wear gloves when handling them.
- Check to make sure hydraulic hoses are not worn or damaged, and are routed to avoid chafing.
- Immediately replace any hydraulic hose that shows signs of swelling, wear, leaks or damage so it does not burst.
- Do not use your hand to check for hydraulic oil leaks. Use a piece of cardboard instead. Hydraulic fluid escaping under pressure can penetrate the skin causing serious injury. If skin penetration occurs, seek medical attention immediately. Relieve all pressure before disconnecting hoses.
- Do not bend or strike hydraulic lines, tubes or hoses, or reinstall them in a bent or damaged condition.
- Inspect tires daily for wear or damage. Check tire pressures weekly with an accurate pressure gauge. Do not inflate tires beyond 35 psi.
- Mounting and dismounting tires from rims can be dangerous and should be performed by trained personnel using correct tools, equipment and procedures.



## WELDING AND GRINDING WORK PRECAUTIONS

**IMPORTANT! A fire extinguisher should be easily accessible during all welding work.**

- Welding repairs are to be performed by a trained welder with proper service instructions. Know the material to be welded and select the correct welding procedure and materials (electrodes, rods, wire) that will provide a weld metal strength equivalent to the parent material.
- Move the machine to a clean, safe area before welding, grinding or using a cutting torch on it. This type of work should only be done in a clean area and not in places that contain combustible liquids, such as fuel tanks, hydraulic pipes or similar.
- Connect arc welder ground as close as possible to work area.
- Work with extra care when welding, grinding or torch cutting near flammable objects.

### WORKING ON PAINTED SURFACES

Heated paint gives off poisonous gases. Therefore, paint must be removed from an area with a radius of at least 4 in (10 cm) before carrying out welding, grinding, or gas cutting. In addition to the health hazard, the weld will be of inferior quality and strength if the paint is not removed.

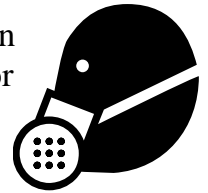

Methods and precautionary measures when removing paint:

- Blasting – use respiratory protective equipment and protective goggles.
- Paint remover or other chemicals – use a portable air extractor, respiratory protective equipment, and protective gloves.
- Grinding – use a portable air extractor, respiratory protective equipment, and protective gloves and goggles.

## **SAFETY CHAIN:**

It is recommended that the safety chain provided with this mower be attached to the towing vehicle at all times.

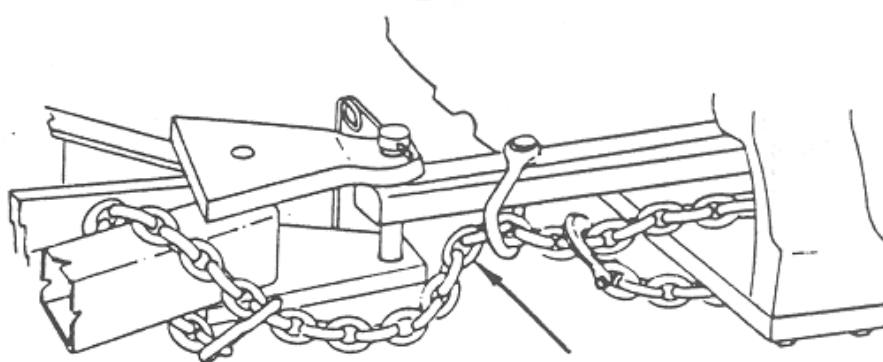

Install a safety chain as shown. After attaching the safety chain, make a test run to the left and right for a short distance to check for proper adjustment. Readjust to eliminate a loose or tight chain.

## **TRANSPORTING MOWERS:**

### **! CAUTION!**

When traveling on public roadways, use flashing amber lights and S.M.V. emblem on rear of mower to provide greater visibility to other traffic.

Once mower is in the raised position, activate tractor hydraulic control valve slightly so that the cylinders will extend and allow the locks to be totally engaged. This way there will be no sudden surges on the hydraulic system when traveling over tough terrain.

### **! WARNING!**

When towing this mower the following information concerning road speed should be strictly adhered to.

<b>WEIGHT OF TOWING VEHICLE</b>	<b>MAXIMUM ALLOWABLE ROAD SPEED</b>
4500 LBS OR MORE	UP TO 20 MPH (32 KM/H)
2300 LBS – 4500 LBS	UP TO 10 MPH (16 KM/H)
2300 LBS OR LESS	DO NOT TOW

### **! CAUTION!**

Always have safety chain attached to towing vehicle.

## **TIRES:**

Upon receiving your mower, check air pressure in the tires and adjust according to specifications.

<b>TIRE TYPE</b>	<b>RECOMMENDED TIRE PRESSURE (PSI)</b>
MOWER DECK TIRES (CASTORS)	24 PSI
MAIN FRAME TIRES	32 PSI

### **CAUTION!**

Never inflate tires beyond 35 pounds per square inch (PSI) to seat beads. Inflation beyond 35 PSI pressure before seating the bead may break the bead or even the rim with an explosive force. If beads have not seated by the time the pressure has reached 35 PSI, deflate the assembly, move tire to another position on the rim and re-lubricate. Inflate tire and inspect both sides of the tires to be sure beads are seated properly. If not, deflate tire, unseat beads and repeat the above mounting procedure. After properly seating beads adjust to pressure recommended.

## **POWER TAKE-OFF:**

### **CAUTION!**

Keep all safety shields in place.

### **CAUTION!**

When operating the power take-off, be sure the tractor shield is always in place, covering the exposed power take-off shaft.

### **WARNING!**

Before dismounting from the tractor, stop the power take-off, put tractor in neutral, set brakes in lock position and shut off engine.

### **CAUTION!**

When ready to engage PTO shaft, be sure engine RPM is at idle speed. Engaging PTO at full throttle will cause high shock loads to driveline, with the potential for future failure.

### **WARNING!**

Do not exceed the recommended PTO speed of 540 RPM.

## **SAFETY & MAINTENANCE DECAL LOCATIONS ON MACHINE:**

ITEM NO.	DESCRIPTION	QTY
1	DANGER – READ MANUAL	1
2	CAUTION - TURNING	1
3	CAUTION – REPLACE SHIELDS	8
4	COMPANY NAME	1
5	DANGER - BLADE HAZARD	7
6	WARNING – OEM PARTS	1
7	CAUTION –DISENGAGE PTO	1
8	GREASING SCHEDULE	1
9	PTO GREASING	1
10	NOTICE – HITCH SETUP	1

ITEM NO.	DESCRIPTION	QTY
11	MOWER MODEL	4
12	DECAL – DANGER – OUTER TUBE	3
13	FRONT DECK HEIGHT	4
14	REAR DECK HEIGHT	2
15	SAFETY SIGN - OUTER GUARD	1
16	CE WARNING DECAL	2
17	SAFETY SIGN – INNER GUARD	2
18	DECAL – DANGER – OUTER SHIELD	3
	GREASE POINT	25

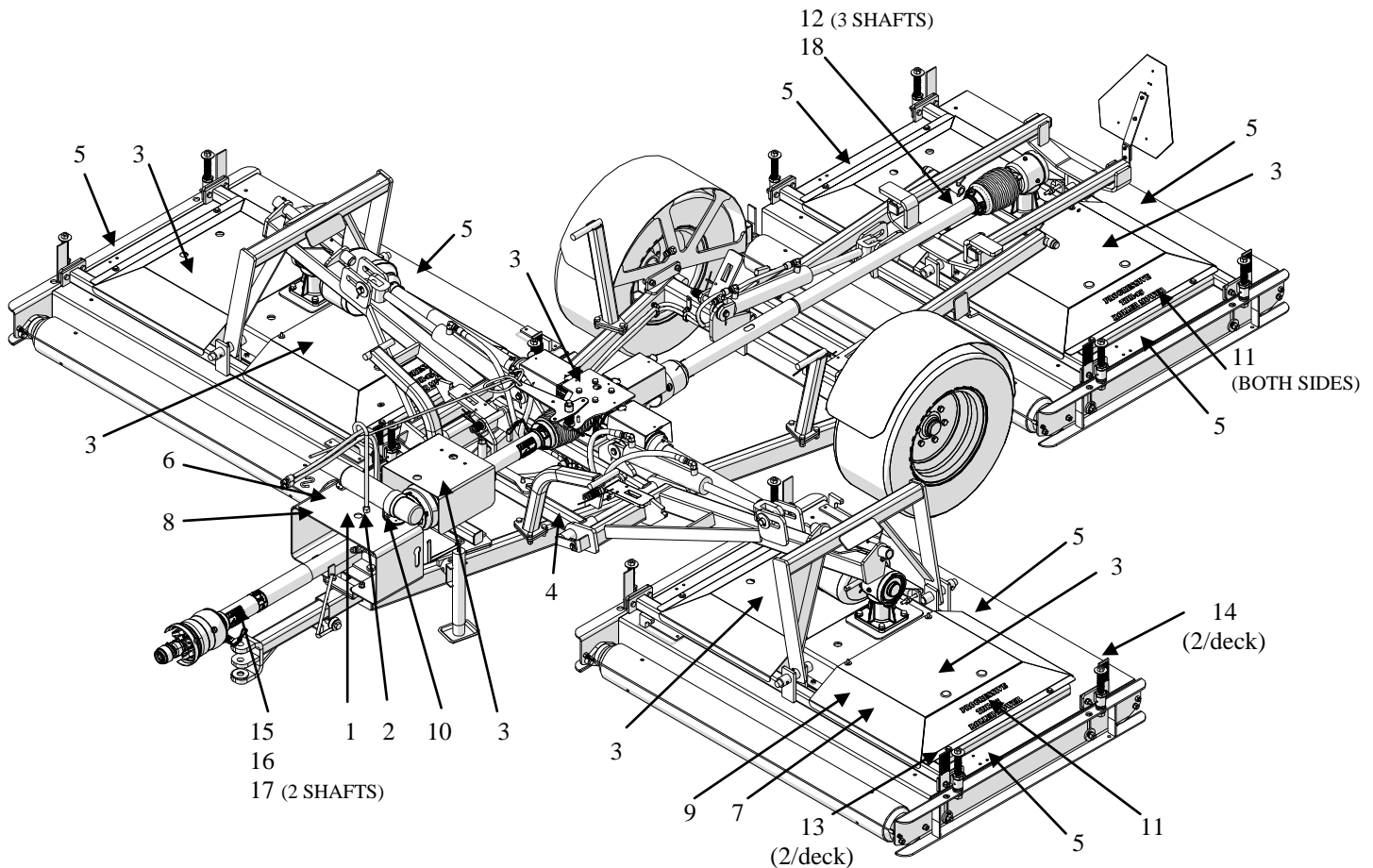

# TDR-15 DECAL LISTING

If decals become faded, damaged, or lost, replace immediately. Order decal according to corresponding Part # below. Complete decal kits are also available.

## TDR-15 DECAL KIT – 524004

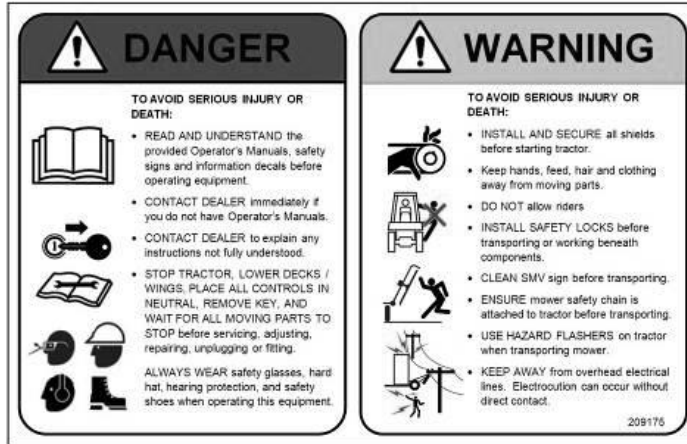

ITEM 1  
(209175)

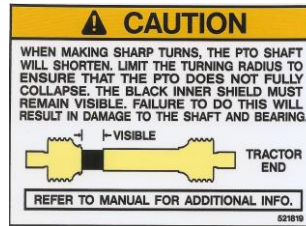

ITEM 2 – A & C  
MODELS  
(521819)

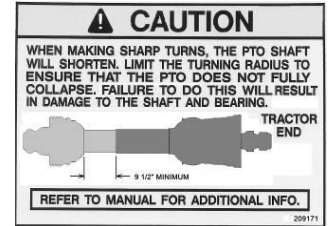

ITEM 2 – B & D  
MODELS  
(209171)



ITEM 3  
(209113)



ITEM 4  
(521817)



ITEM 5  
(209173)



ITEM 6  
(209115)



ITEM 7  
(521820)

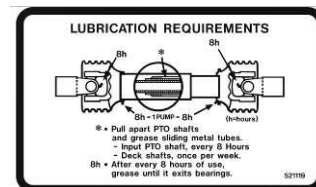

ITEM 8  
(521119)

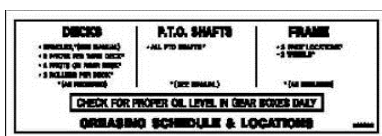

ITEM 9  
(526003)

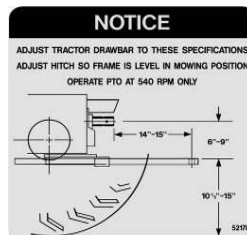

ITEM 10  
(521784)

## PROGRESSIVE TDR-15 ROLLER MOWER

ITEM 11  
(209127)



**ITEM 12**  
**(521451)**



**ITEM 14**  
**(209139)**

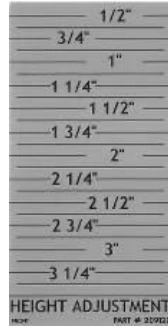

**ITEM 15**  
**(209123)**



**ITEM 16**  
**(210237)**



**ITEM 17**  
**(210238)**



**ITEM 18**  
**(210239)**



**ITEM 19**  
**(521455)**



**GREASE POINT DECAL**  
**(521014)**

## **MAINTENANCE SAFETY:**

- Never work on mower without safety locks in place, if decks are in raised position.
- Keep tractor and mower in good operating condition and all safety devices in place.
- Frequently check blade mounting bolts for tightness.
- Periodically check to ensure all bolts are tight and that all nuts, screws and cotter pins are properly installed to ensure that the mower is in a safe condition.

## **PROPER TORQUE FOR FASTENERS:**

The chart lists the correct tightening torque for fasteners on Progressive Turf Equipment mowers. When bolts are to be tightened or replaced, refer to this chart to determine the proper torque except when specific torque values are assigned in the manual. Only SAE grade 5 fasteners are to be used in the assembly of this machine, or as otherwise specified in this manual.

### **Bolt Head Markings**

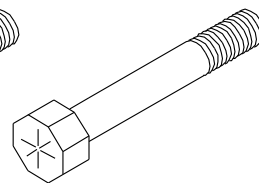
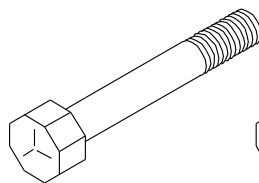
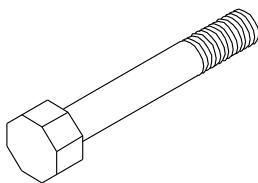

**SAE Grade 2**  
(No Dashes)

**SAE Grade 5**  
(3 Dashes)

**SAE Grade 8**  
(6 Dashes)

<b>Bolt Diameter (in.) (SAE Grade 5 Bolts)</b>	<b>Recommended Torque in Foot Pounds (Newton-Meters)</b>
5/16	21 (28)
3/8	38 (52)
7/16	55 (75)
1/2	85 (115)
9/16	125 (170)
5/8	175 (240)
3/4	300 (410)
7/8	450 (610)
1	680 (925)
1" LH Spindle Nut	60 (82)

## **OPERATING THE MOWER:**

A careful and knowledgeable operator is the best insurance against an accident.  
Allow no riders on any equipment.

If tractor is equipped with R.O.P.S., use the seat belt for maximum protection.

Make sure that everyone is clear of the tractor and mower before starting the engine or operating.

## **DAILY CHECK LIST:**

1. Always wear relatively tight and belted clothing to avoid entanglement in moving parts. Wear sturdy, rough soled work shoes. Never operate tractor or implements in bare feet, sandals or sneakers.
2. Check that mower is properly and securely attached to tractor with a safety chain.
3. Ensure all safety shielding is properly installed and check that all nuts and bolts are secure and pins are properly cotterpinned.
4. Check condition of blades and security of attachment.
5. Ensure mower is properly mounted, adjusted and in good operating condition.
6. Clear area of stones, branches or other debris that might be thrown causing injury or damage.
7. Never permit any person other than the operator to ride or board the tractor at any time.
8. Check that all lubrication points with grease fittings have been lubricated as per schedule.
9. Check all gearboxes for proper amount of gear oil. Mower must be on level surface when this is done.

Be sure actuator pull rope is properly secured and will not become entangled in PTO shaft.

## HITCHING MOWER TO TRACTOR:

### **! CAUTION!**

Attach mower to drawbar only.

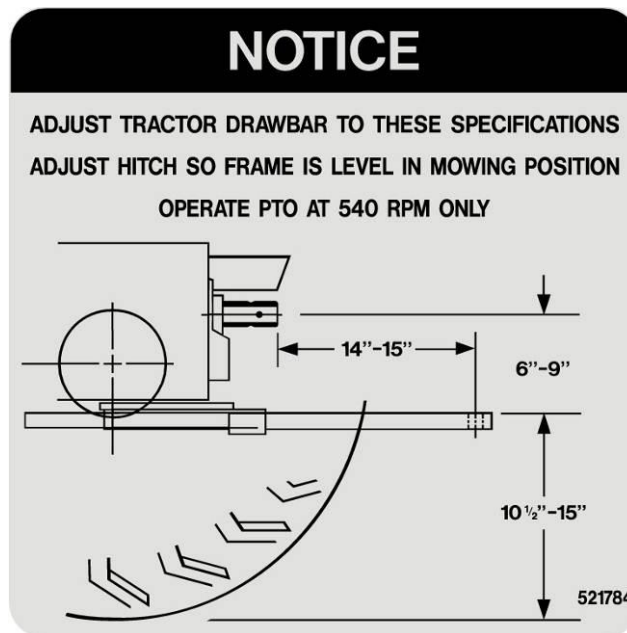

- Drawbar should be adjusted so it is 14" to 15" from the center line of the draw pin hole to end of PTO shaft. This is critical for proper PTO shaft operation.
- Adjust hitch or drawbar so mower frame (Item #1, Page 33) is at the most level position in relation with the ground. This will ensure proper flotation of the wing decks.

### **! CAUTION!**

Safety chain must always be attached to towing vehicle.

### **! CAUTION!**

When towing mower on any roadways, lock brakes together. Use proper lighting and marking devices according to the local regulations.

**NOTE:** If the three-point hitch is attached to tractor, be sure it will not contact any part of the mower when making sharp turns. Mount the hose support bracket so the large access hole is directly over the grease fitting on the hanger bearing. The hose support rod may have to be bent back slightly to clear the three point hitch arms.

## **LEVELLING THE MOWER & PTO:**

For proper mower operation and maximum PTO life, the mower hitch and PTO driveline must be setup correctly.

- a) When the mower is connected to the tractor, the mower hitch frame “A”, should be as close to level with the ground as possible.
- b) The connecting hitch “B” can be removed and turned over to give more height adjustments. Set in the best position for the mower frame to be as level as possible.
- c) To ensure proper life of the PTO shaft, the driveline from the mower gear box “D” to the PTO shaft “E” on the tractor should be in a straight line.

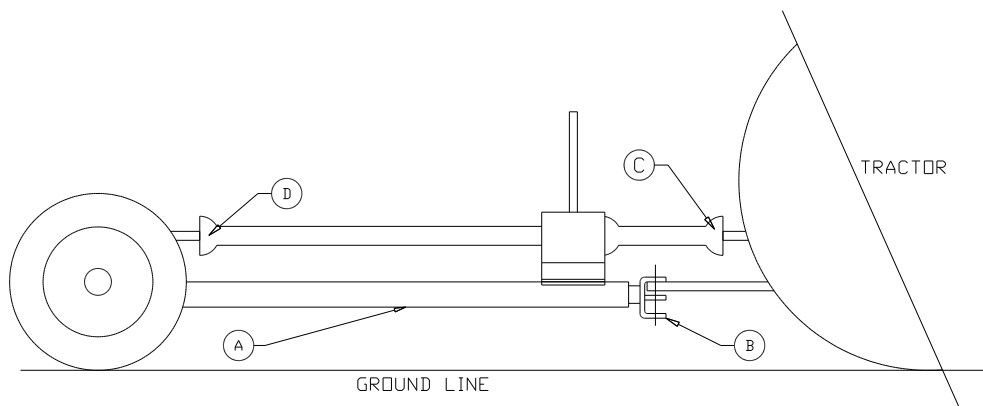

## **CONNECTING THE PTO SHAFT:**

- a) Ensure that the tractor engine is shut off and the parking brake is locked.
- b) Holding the PTO against the end of the tractor PTO shaft, rotate the tractor PTO by hand until the shaft slides on slightly.
- c) Slide the locking collar on the PTO backwards, releasing the locking mechanism. Hold and slide the PTO on.
- d) Release the locking ring and pull the PTO shaft backwards until the locking mechanism snaps into place.
- e) Push the shaft forward and backwards to ensure that this is securely locked in place.

### **! CAUTION!**

If the PTO shaft comes off during operation, it may cause personal injury and damage to the PTO shaft and tractor PTO. When checking, make sure the locking collar is locked, and that the shaft is not just jammed against the end of the tractor PTO shaft.

## **INSTALLING PTO SHAFTS:**

The three identical PTO shafts are used to drive the mower decks. Each PTO shaft will have one end designated a tractor end. This end should be hooked up to the main gearbox.

### **! CAUTION!**

The PTO shafts from the two wing decks must be timed when mounted to the gearbox. See photo below. Mount the one side first with the yoke laying flat. The opposite side must be mounted with the yoke laying as flat as possible. ie. Timed.

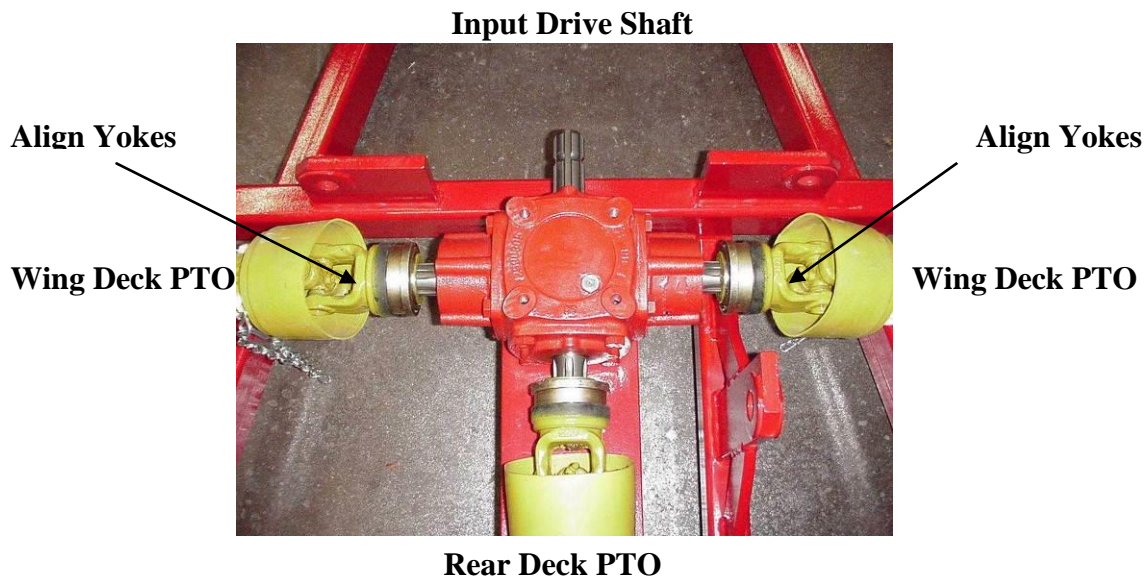

- All PTO shafts have a short chain attached on both ends. Find a location to wrap or hook on short chain. Be sure that when decks are brought into transport position, the safety chain will not bind or pull PTO shield.
- The Intermediate shaft is installed with the large bell end onto the main gear box. The PTO mount bracket is then installed by sliding the PTO end through the flange bearing, leaving the mounting bolts loose. Do not forget to install the PTO spacers to level the driveline. See section on “Hitching to the Tractor”.

## **CHECK PTO LENGTH DURING TURNS:**

During the mowing operation the tractor should be able to make turns without damage to the driveline. To ensure proper setup, check the following conditions:

- a) With the tractor and mower aligned, and the input PTO straight, turn the shields on the input PTO to check that the holes line up for greasing the input shaft tubes. If not, you will have to lengthen or shorten the drawbar. It should be 14" to 15" from the end of the PTO shaft to the center of the draw pin hole.
- b) With the tractor in the lowest gear and traveling very slowly, make a sharp turn to the right as required for mowing.
- c) Watch the PTO shielding to make sure the PTO shaft does not totally collapse. There should be 1" to 2" of black PTO shielding left at maximum turn. See picture below. (A&C models only)



1" to 2" of BLACK

**NOTE:** This is not the worst condition. Making turns while the tractor is angling up a hill will cause the PTO shaft to collapse even more. The operator should avoid making sharp turns on uneven ground.

## **CUTTING HEIGHT ADJUSTMENT:**

There are four height adjusters per mowing deck. Each adjuster (located in each corner of the deck) must be adjusted to the same height to ensure a smooth even cut. A wrench for this purpose is provided. In addition, each deck must be adjusted the same so that a level cut is obtained across the whole cutting width of the mower. Mower cutting height adjustment is made by turning a 5/8" nut on top of an acme threaded rod which makes up the height adjuster. A washer under the nut indicates the height against the decal. There are an infinite number of adjustments available from 1/2" to 4". Moving the adjuster up and down moves a side channel that mounts the front and rear rollers. Before attempting to make height adjustments, the locking bolt on the side channel adjacent to the adjuster must be loosened. When the desired adjustment is made, be sure to tighten the locking bolt and adjuster jam nut to maintain the adjusted height. The height decals at the back of the deck are set 1/4" lower, so that the back actually cuts 1/4" higher, this will provide a better cut, prolong the life of the blades, and reduce horsepower requirement. This will also make the side channel look uneven, but this is correct.

### **TDR-15 HEIGHT ADJUSTER**

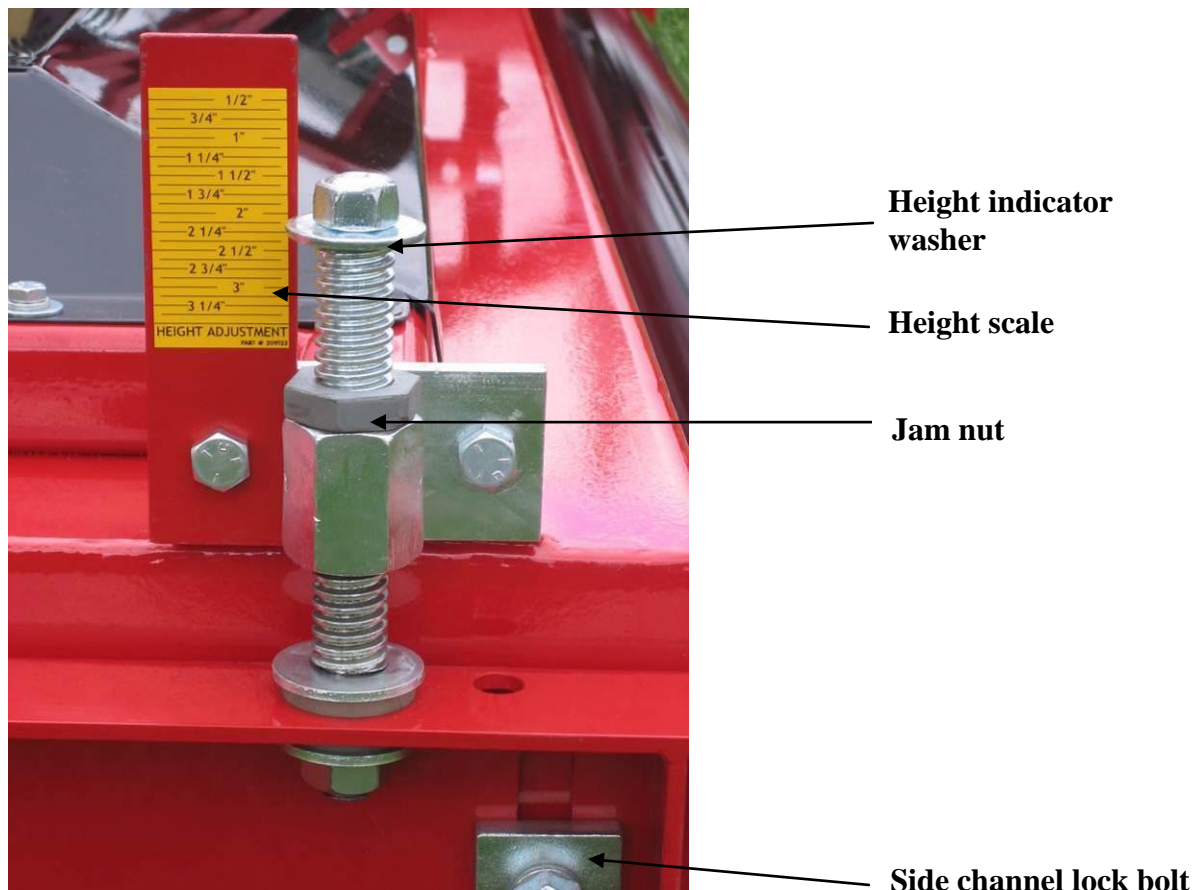

## **Pro Lift-N-Turn™ SYSTEM**

Your TDR-15 is equipped with the Pro Lift-N-Turn® system. This feature allows the operator to lift all three cutting decks just off the ground to negotiate a tight turn without shutting down the PTO. Using this system will eliminate roller drag and scuffing while turning at the end of a row. When mowing in fields with ribbons or irrigation ditches, the operator can save time moving from section to section without shutting down the PTO and raising the decks to the full transport position by utilizing the Pro Lift-N-Turn® system.

To actuate the Pro Lift-N-Turn® System, the operator lifts the decks during operation until the lock plate contacts the stop plate fastened to the frame. Once the mower is again in position to mow, the operator can lower the decks and continue mowing. There is no need to disengage the PTO.

# GREASE COMPATIBILITY

## What Grease Is:

- Grease is essentially a distilled petroleum product in the form of mineral oil (or a synthetic) which has a thickening agent such as lithium, calcium, barium, sodium, or aluminum.
- Many of the thickeners will work for similar situations, but when mixing greases with different thickeners, one must review compatibility. Grease incompatibility will actually decrease the lubrication ability of the grease, and cause premature part failure.
- There may be other additives in the grease that impart special properties. These properties may be “high temperature”, “extreme pressure”, etc.

## What We Use:

- Our bearing supplier uses Shell Alvania 2
- Progressive uses Texaco Multifak EP 2
- EP means extreme pressure
- Both greases have:
  - A mineral oil base
  - A lithium thickener
  - The mineral oil has a NLGI Grade 2
  - Both greases are compatible with each other

## Note:

- If a thickener other than lithium is used, the existing grease will be contaminated and the lubrication properties may be lost.
  - If a synthetic base oil is used rather than a mineral base oil, the grease will again be contaminated and the lubrication properties may be lost
  - Molybdenum Disulfide (Moly) is an additive used in slow moving, extreme load applications. The particles in the “Moly” will actually increase bearing wear in a mower spindle. Our grease does not contain Moly.
  - The blade spindle temperature should never go above 120°F if properly greased; we do not recommend high temperature grease.
- A grease with these features is considered to be a “General Purpose Grease”. Use on all grease point locations on your Progressive Mower.

## Our Recommendation for Grease Compatibility:

The grease you use for the blade spindle assemblies must have these properties:

- NLGI grade 2
- Lithium thickener (NOT LITHIUM COMPLEX OR LITHIUM 12-HYDROXY)
- Kinematic Viscosity at 40°C is no greater than 190 cSt
- Dropping Point Less than 400° F
- General Purpose Grease, Not Heavy Duty
- No MOLY (molybdenum disulphide) additives in the grease
- No synthetic grease
- No High Temperature Grease
- Check the properties of the grease you wish to use with your supplier prior to use.

## LUBRICATION:

A properly maintained lubrication schedule will provide a smooth running machine for many years. All pivot locations have grease fittings. The following information shows and describes where all lubrication points are located.

<b>DECKS</b>	<b>P.T.O. SHAFTS</b>	<b>FRAME</b>
<ul style="list-style-type: none"> <li>• Spindles* (See Manual)</li> <li>• 3 Pivots per Wing Deck*</li> <li>• 2 Pivots on Rear Deck*</li> <li>• *As Required</li> </ul>	<ul style="list-style-type: none"> <li>• Main Input*(See Below)</li> <li>• Deck Drive, 4 Locations per Shaft*</li> <li>• Pull Apart Sliding Tubes once per week and lubricate</li> <li>• *As Required</li> </ul>	<ul style="list-style-type: none"> <li>• 8 Pivot Locations*</li> <li>• 2 Wheels*</li> </ul> <p>*As Required</p>
<div style="border: 1px solid black; padding: 5px; display: inline-block;"> <p>CHECK FOR PROPER OIL LEVEL IN GEARBOXES DAILY</p> <p><b>GREASING SCHEDULE &amp; LOCATION</b></p> </div>		

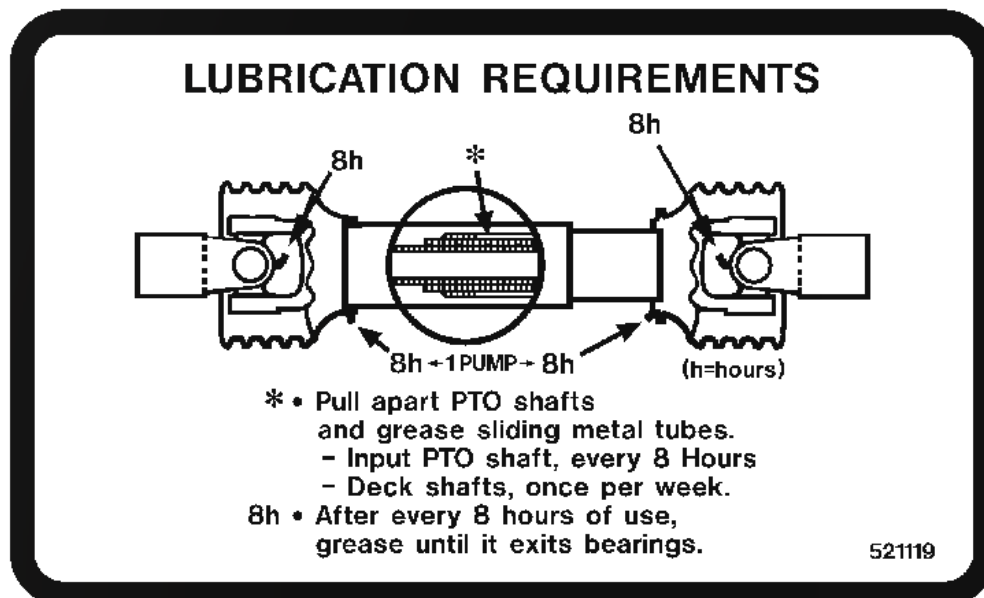

## BLADE SPINDLE GREASING:

The top bearing on all spindle assemblies has a shield only. This allows grease to exit and relieves any pressure build up inside spindle housing, when greasing. Greasing of blade spindles should continue until grease can be seen exiting between the top bearing. Some working conditions will require this operation to take place every 4 to 5 running hours because of hot working areas. Cooler working areas will only require greasing every 8 to 10 hours. A proper greasing schedule can only be determined by operator, depending on working conditions in your particular area.

## **GEARBOX OIL LEVELS:**

**IMPORTANT! DO NOT OVERFILL! MOWER MUST BE LEVEL WHEN CHECKING GEARBOX OIL LEVEL**

### **DECK GEARBOXES:**

Gearboxes all have an oil level plug located on the side of the gearbox. Oil should reach the bottom of this hole. If oil level is low, add oil through top plug hole of casing until oil just starts to flow out of side oil level hole. Replace and tighten plugs. Use 80W90-gear oil or equivalent.

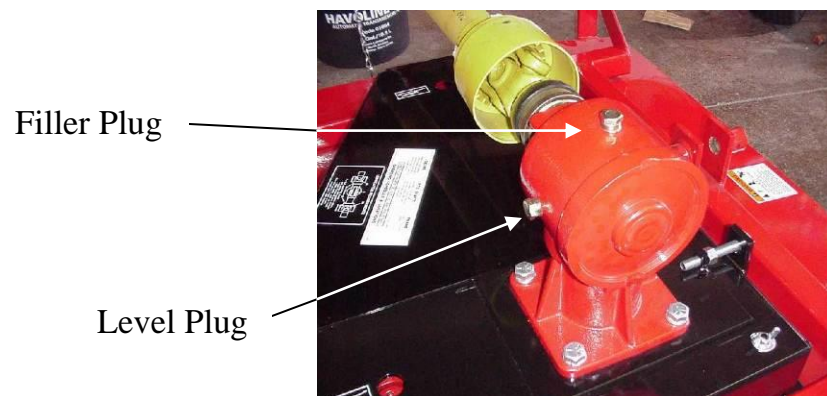

### **MAIN GEAR BOX:**

The main gearbox has a combination filler plug and dipstick. Remove the plug, dry off the dipstick and replace to check oil level. It must touch the oil in the gear box. Add oil as required. Use 80W90 gear oil or equivalent. Replace and tighten the plug.



## **MAINTENANCE:**

### **WARNING!**

Turn tractor engine off before performing any maintenance.

### **CAUTION!**

Always use personal protection devices such as eye and ear protectors when performing maintenance functions.

### **WARNING!**

When completing a maintenance or service function, make sure all safety shields are installed before placing mower in service.

## **BLADE SERVICING:**

### **WARNING!**

Be sure safety locks are in place when working on decks in the raised position. The tractor hydraulic system could fail, causing decks to fall and crush anything under them.

### **CAUTION!**

Do not handle mower blades with bare hands. Careless or improper handling may result in serious injury.

Inspect blades before each use to determine that they are mounted tightly and are in good condition. Replace any blade that is bent, excessively nicked, worn or has any other damage. Small nicks can be ground out when sharpening.

### **WARNING!**

Only original equipment blades should be used when replacing worn out mower blades. They are made of special steel alloys and subjected to rigid heat-treat and inspection requirements. Substitute blades may not meet these rigid specifications and **MAY BE DANGEROUS.**

## **BLADE REMOVAL AND INSTALLATION:**

Two, 1/2" X 1 3/4" grade 5 bolts with lock washers and nuts hold blade to blade spindle support bar. When changing blades, be sure that these fasteners are in good condition so they will not come loose during operation.

## **BLADE SHARPENING:**

**IMPORTANT** - When sharpening blades be sure to balance them. Unbalanced blades will cause excessive vibration, which can damage blade spindle bearings. Vibration may also cause structural cracks in spindle housing.

- Follow original sharpening pattern as shown. Sharpen blade to a razor edge. Protect hands when sharpening. Do not sharpen backside of blade.

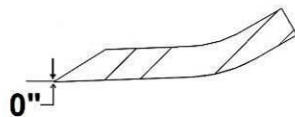

## **BLADE SHARPENING**

## **SPINDLE INSPECTION:**

- Spindles are equipped with two roller ball bearings. Adjustment is set by tightening the 1” left hand nut to 60 ft-lbs. torque for proper setting.
- Periodically inspect blade spindles by grasping blade, and moving from side to side. If any free play is noted, replace or repair.

## **SPINDLE ASSEMBLY REMOVAL:**

1. Remove blade from spindle.
2. Remove belt shield. Loosen 4 bolts that hold gearbox to mount.
3. Loosen 1/2” x 3 1/2” tap bolts and slide gearbox toward front until belt is easy to remove.
4. Remove belt.
5. Remove 4 bolts attaching spindle assembly to mower frame and remove as a unit, since pulley will come out through the hole in the deck.

## **SPINDLE ASSEMBLY INSTALLATION:**

Reverse above procedure. Be sure spindle mounting area of deck is clean of any foreign material before attaching spindle assembly.

## **SPINDLE REPAIR:**

- Spindle repair requires special skills and tools. If your shop is not properly equipped or your mechanics are not properly trained in this type of repair, you may be time and money ahead to use a new spindle assembly.
- Remove pulley from spindle assembly. Place assembly in press and force spindle down through housing. Once pressed apart, replace bearings, as removal will have damaged bearings internally.

## ASSEMBLY OF SPINDLE:

Only use a press that has the ram and bed 100% square to each other. If bearings are not square in housing, bearings will wear out prematurely. Press on outer race when inserting into hub and press on inner race when installing on spindle.

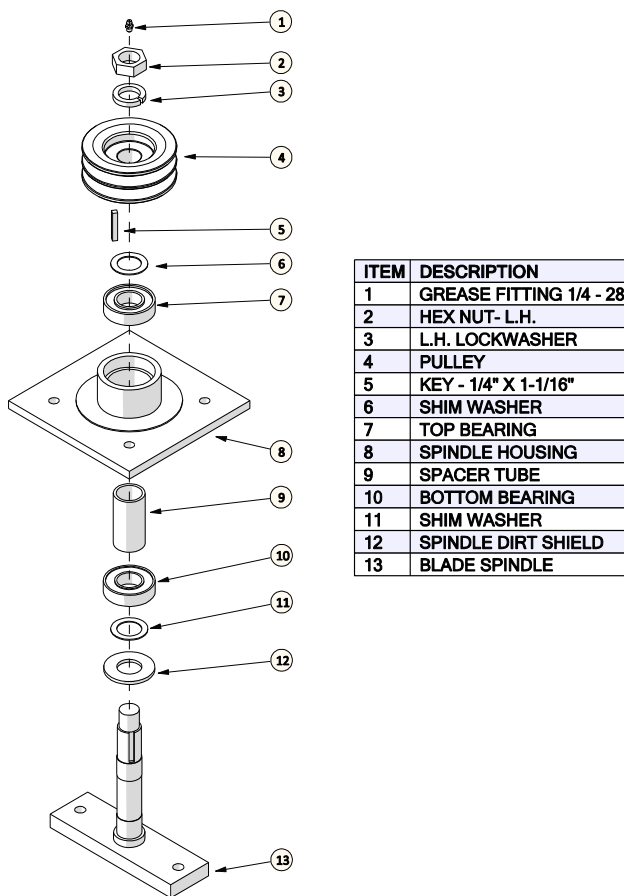

If bearings are being changed, be sure to check bearing spacer for wear. If wear is noticed, insert new spacer. This is critical because if spacer is short by only .010", the top bearing will start to bind and will result in premature failure.

Bearing with seal and shield combination will be pressed into the blade side of the hub first with the seal side facing out. Next, set spindle on press bed, install dirt shield and shim first (as per diagram) set hub, bearing end down, onto spindle. You must use a tube (Note: both ends must be square) which will slide over spindle and press on inner race of bearing, until seated against shim.

Insert bearing spacer tube with hole end up. Set remaining bearing with shield side up, open side on first, onto spindle. Press on inner race (this bearing will be a loose fit in the hub so it will seat itself properly).

When all parts have been installed on spindle, torque left hand nut to 60 ft-lbs. and then tighten set screws in pulley. Once the assembly is complete, fill with quality grease until it can be seen exiting the top bearing. Rotate the housing six revolutions by hand so the bearings will have the grease worked into them, and at the same time check for free movement. The assembly is now ready for installation into the mower deck.

## **“V” BELT ADJUSTMENT:**

Begin by loosening 4 bolts at the base of the gearbox. Adjusting long threaded bolt slides the gearbox back, tightening belt. After proper tension is achieved, tighten 4 bolts at base of gearbox. You may have to place a ½” nut under the head of the long threaded bolt to increase your adjustment length.

When changing belts, removal of grease fitting from the top of the center spindle will make installation easier. Be sure belts run in proper groove.

## **“V” BELT TENSION:**

Proper belt tensioning is a fundamental factor in the successful V-belt operation. Lack of tension will cause slippage, and too much tension will cause excessive belt stretch as well as damage to the drive components, such as bearings and shafts. Therefore, to ensure proper belt tension, the following procedure is recommended.

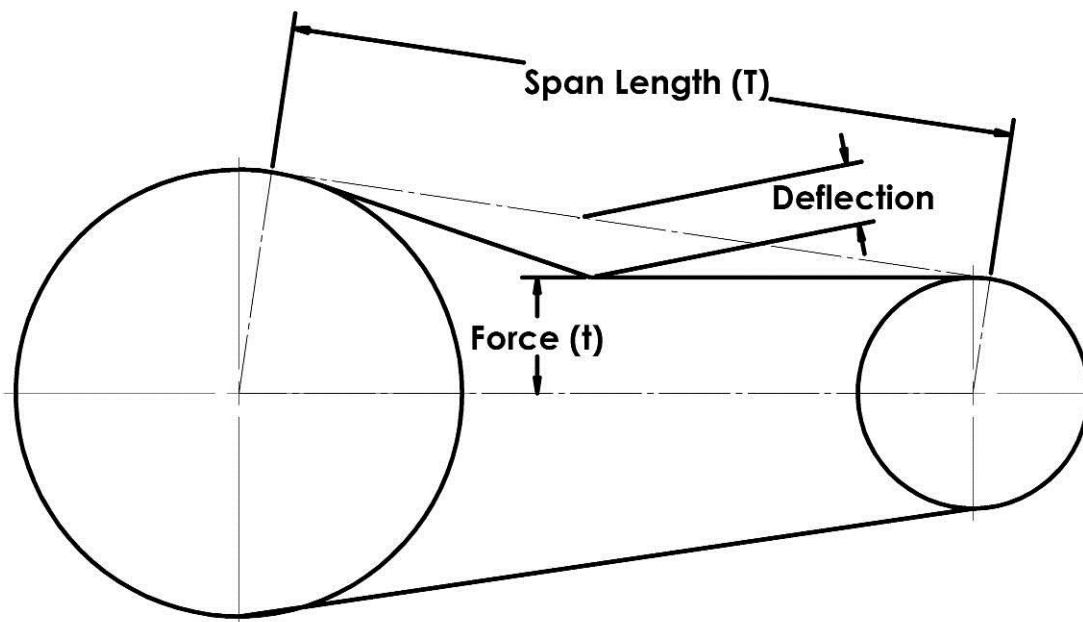

### **CHECKING BELT TENSION**

At the mid-point of the span, apply a deflection force with a spring scale in the direction perpendicular to the span until the belt is deflected the 3/8”.

The recommended force to deflect the belt is a minimum of 4.9 lbs. to a maximum of 7.3 lbs.

The first 24 to 48 hours of operation is the belt “run in” period. To ensure satisfactory belt performance, belt tension should be checked during this time period.

## **HYDRAULICS:**

- The hydraulic system on your Progressive mower is a simple cylinder system used to raise and lower the cutting decks into position. Each cylinder contains a .035 diameter restrictor orifice, which is located on the rod end to slow the speed of travel.



Restrictor Orifice

- When reconnecting the quick disconnects to the tractor, be sure that both ends are clean. Dirt in the hydraulic system can block the orifice in the line throttle valve or even score the cylinder tubes.
- Hydraulic fluid escaping under pressure has enough force to penetrate the skin. Seek medical attention at once if injured by escaping fluid. During your daily inspection repair all leaks before they create a major problem. Relieve all pressure before working on, or disconnecting the line in the hydraulic system.
- If crimp-on hose ends are ever changed, be sure they are compatible with the hose, to provide the proper crimping pressure.

## TROUBLE SHOOTING:

PROBLEM	CAUSE	REMEDY
Belt slippage	Lack of tension oily drive conditions	Increase tension Clean up drive
Rapid belt wear	Belt slippage belt not in proper groove	Increase tension Place in proper groove
Belt squeal	Belt slippage	Increase tension
Over-heated bearings	Belt slippage excessive drive tension	Increase Tension Tension drive properly
Wing deck, corner support bent	Insufficient spring tension	Increase Tension by adjusting eye bolt
Wing locks hard to disengage	Cylinder not pulling wing up all the way	Adjust clevis on end of cylinder
Mower deck will not lower	Orifice in line throttle valve plugged	Remove line throttle valve, Remove obstruction from orifice and reassemble
Vibration on turning.	Draw bar length incorrect	Adjust drawbar length To specification
Input shaft does not collapse easily on turning.	Lack of grease at intermediate location of drive shaft	Remove driveshaft and pull apart. Grease splines. Grease every 8 hours.
Premature spindle bearing failure.	Lack of lubrication or grease is contaminated	See grease information and ensure grease being used is compatible. Grease per instructions



# Parts List

## TDR-12 & TDR-15

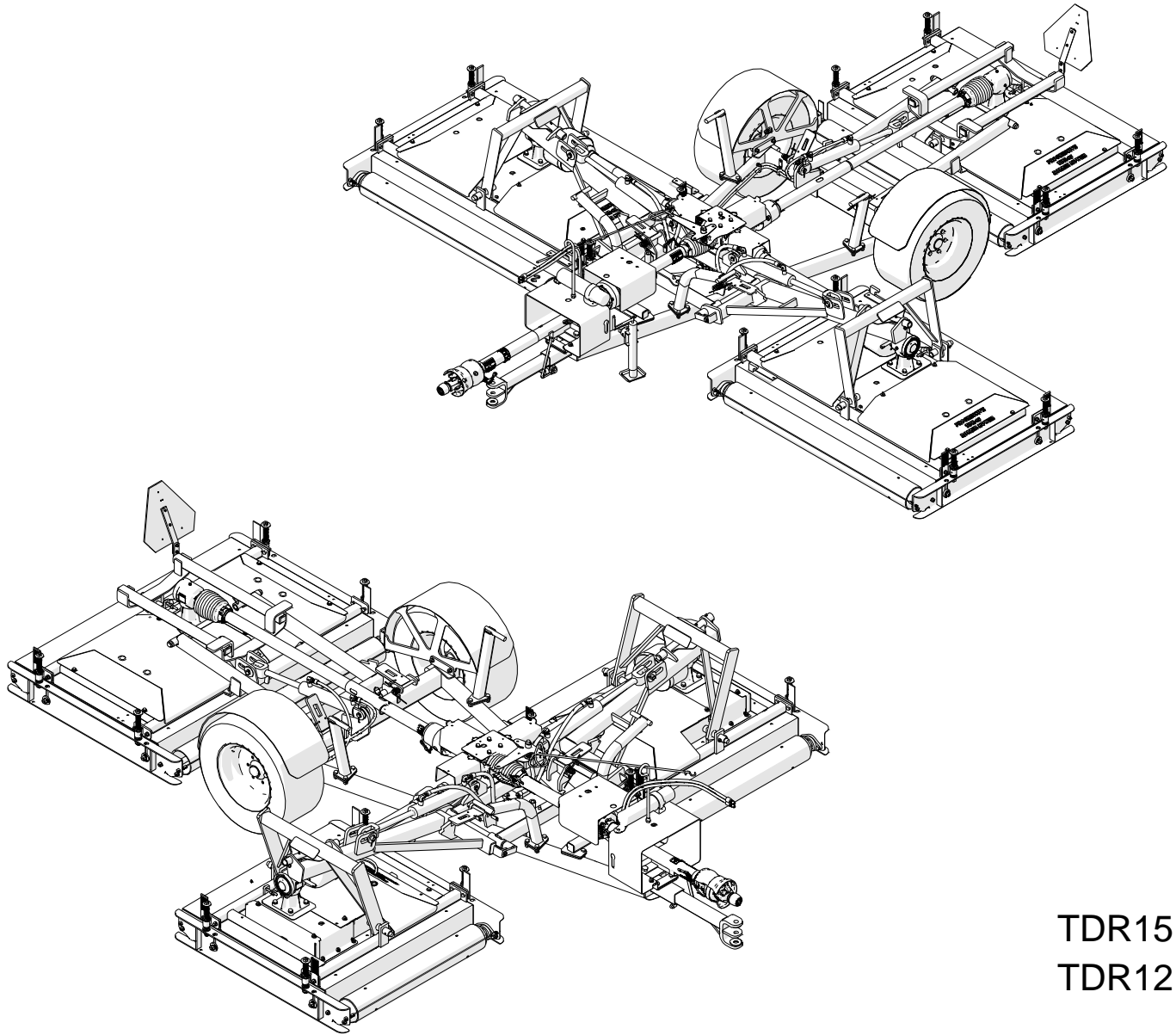

TDR15  
TDR12

 **DANGER!**

Si No Lee Ingles, Pida Ayuda a Alguien Que Se Lo Lea  
Para Que le Traduzca Las Medidas de Seguridad

Effective serial numbers:  
TDR-15: 1315121 and up.  
TDR-12: 1312033 and up.

P.N. 120518

Issue Date: November 2014

## Serial Number Location

The serial number plate for the machine is located on the left side of the main frame tube at the front of the machine.

For quick reference, record the following information:

Model: \_\_\_\_\_

Serial Number: \_\_\_\_\_

Date purchased: \_\_\_\_\_

Always state this information when contacting your selling dealer and when ordering spare parts.

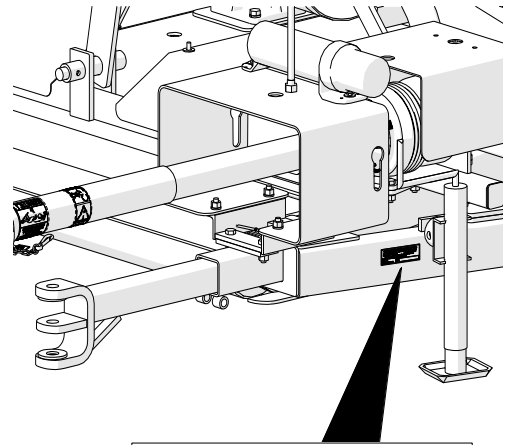

PROGRESSIVE TURF EQUIPMENT INC. 137 West William St., Seaforth Ontario Canada Phone 519-527-1080 Fax 519-527-2275 Web Site: www.progressiveturfequip.com	
PRODUCT: Rotary Finishing Mower	
MODEL:	S.N.
Made In Canada	

## Parts Information

Use only Genuine Original Equipment Manufacturers (O.E.M.) replacement parts. The use of "will fit" parts may reduce machine performance, void machine warranties and present a safety hazard. Use Genuine OEM parts.

## Progressive Turf Equipment Inc.

137 West William Street  
Seaforth, Ontario  
Canada  
N0K 1W0

Phone: 800-668-8873

Fax: 519-527-2275

[www.progressiveturfequip.com](http://www.progressiveturfequip.com)

## Maintenance

Maintenance should always be performed by a qualified service technician familiar with servicing similar equipment, using good safety and workmanship practices.

**Always observe proper lock-out procedures when performing any maintenance work.** Other than maintaining the blade spindles or blades, always lower all decks before performing maintenance. Block and or support machine using equipment designed for the task. When maintaining blades or spindles, always ensure locks are seated correctly in place. When performing hydraulic maintenance, ensure that pressure has been released.

It is imperative that the operator or qualified service technician reads and understands all the safety information in the Operator's Manual before proceeding. Failure to follow the instructions or heed the warnings could result in injury or death. **Proper care is your responsibility.**

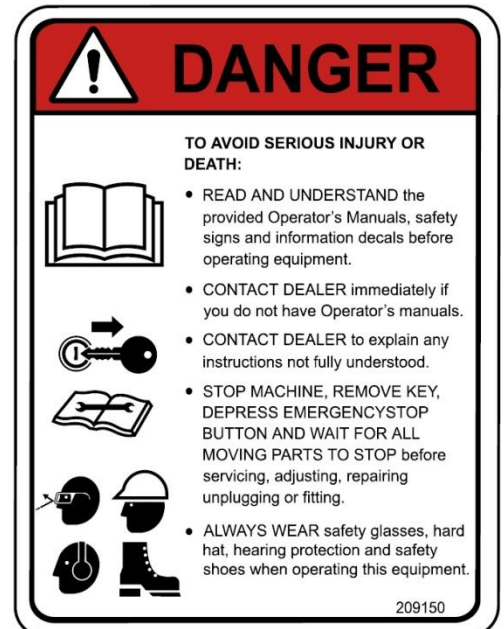

## PARTS ORDERING GUIDE

The following instructions are offered to help eliminate needless delay and error in processing purchase orders for the equipment in this manual.

1. The Parts Section is prepared in logical sequence and grouping of parts that belong to the basic machine featured in this manual. Part Numbers and Descriptions are given to help locate the parts and quantities required.
2. The Purchase Order must indicate the Name and Address of the person or organization ordering the parts, who should be charged, and if possible the serial number of the machine for which the parts are being ordered.
3. The purchase order must clearly list the quantity of each part, the complete and correct part number, and the basic name of the part.
4. The manufacturer reserves the right to substitute parts where applicable.
5. Some parts may be unlisted items which are special production items not normally stocked and are subject to special handling. Request a quotation for such parts before sending purchase order.
6. The manufacturer reserves the right to change prices without notice.



# Table of Contents

<b>SERIAL NUMBER LOCATION.....</b>	<b>ii</b>
<b>1 DECK ASSEMBLY .....</b>	<b>2</b>
1.1 BLADE SPINDLE ASSEMBLY – GREASABLE.....	2
1.2 BLADE SPINDLE ASSEMBLY – MAINTENANCE FREE.....	3
1.3 DECK ASSEMBLY – TDR 15 WING & REAR (ALL).....	4
1.4 WING DECK ASSEMBLY – TDR-12.....	5
1.5 GEARBOX ASSEMBLY .....	6
<b>2 FRAME ASSEMBLY .....</b>	<b>7</b>
2.1 FRAME ASSEMBLY.....	7
2.2 LIFT ASSEMBLY.....	8
2.3 WING LOCK ASSEMBLIES.....	9
2.4 WHEEL ASSEMBLIES .....	10
<b>3 HYDRAULICS .....</b>	<b>11</b>
3.1 HYDRAULICS .....	11
<b>4 DRIVELINE.....</b>	<b>12</b>
4.1 DRIVELINE .....	12
4.2 INPUT PTO SHAFT .....	13
4.3 INPUT PTO SHAFT – TDR-15 D MODEL.....	14
4.4 INTERMEDIATE PTO SHAFT.....	15
4.5 WING DECK PTO SHAFT .....	16
4.6 REAR DECK PTO SHAFT .....	17
4.7 4 - WAY GEARBOX.....	18
4.8 DECK GEARBOX – STANDARD ROTATION .....	19
4.9 DECK GEARBOX – REVERSE ROTATION .....	20
<b>5 DECALS .....</b>	<b>21</b>
5.1 SAFETY .....	21
5.2 GENERAL INFO .....	23

# 1 DECK ASSEMBLY

## 1.1 Blade Spindle Assembly – Greasable

TDR 15 up to Serial # 1415136

TDR 12 up to Serial # 1412036

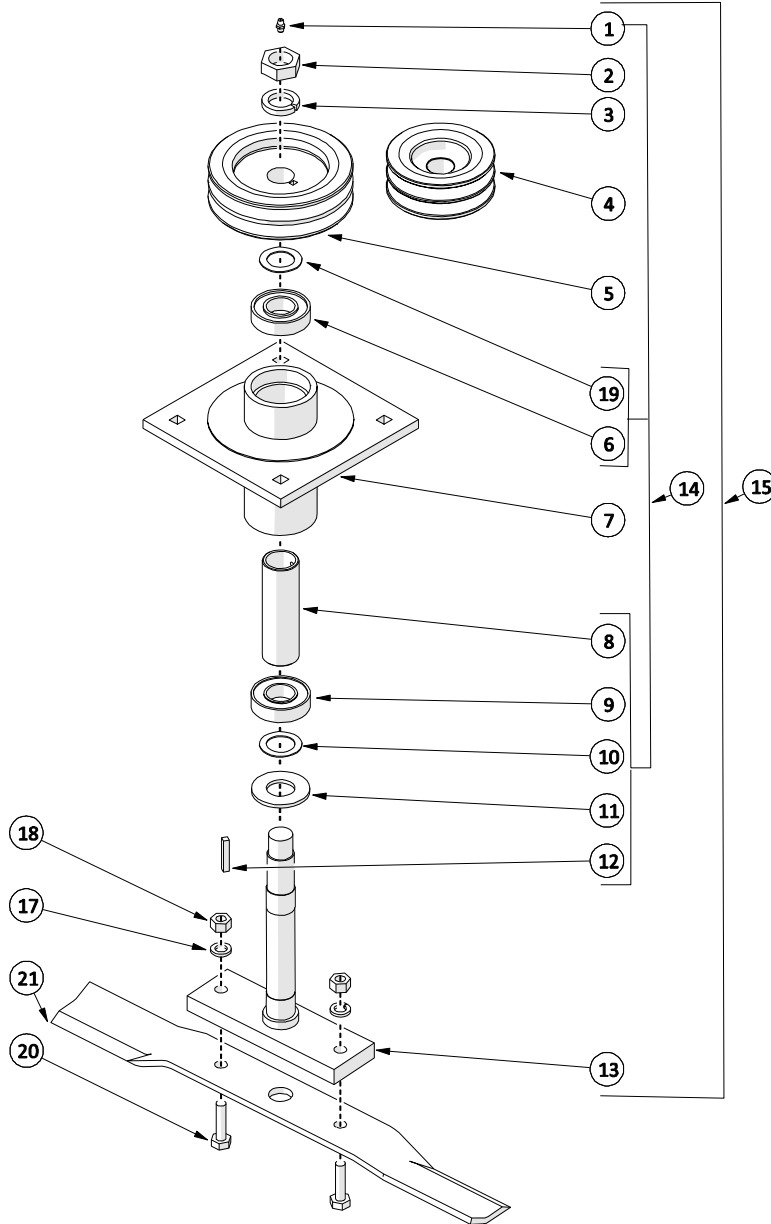

ITEM	PART #	DESCRIPTION	QTY	SN
1	O.L.	GREASE FITTING 1/4 - 28	1	
2	521003	HEX NUT- L.H.	1	
3	521002	LOCKWASHER L.H. (3 PCS)	1	
4	521773	PULLEY - 4.4"	1	1
5	521790	PULLEY - 5.95"	1	2
6	-	BEARING - TOP STEEL SHIELD UP	1	
7	524220	TDR 15 SPINDLE HOUSING	1	
8	-	SPINDLE SPACER TUBE	1	
9	-	BOTTOM BEARING, STEEL SHIELD UP	1	
10	-	SHIM WASHER 1.188"	1	
11	-	SPINDLE DIRT SHIELD	1	

ITEM	PART #	DESCRIPTION	QTY	SN
12	O.L.	KEY - SPINDLE - 1/4" X 1-9/16"	1	
13	524224	TDR-15 BLADE SPINDLE	1	
14	524390	SPINDLE REBUILD KIT	1	
15	524232	BLADE SPINDLE ASSY - 5.9" PULLEY	1	2
16	524230	BLADE SPINDLE ASSY - 4.40" PULLEY	1	1
17	301304	LOCK WASHER- 1/2 PL	2	
18	305604	HEX NUT - 1/2NC GR5 PL	2	
19	-	1.125" SHIM WASHER	1	
20	-	HEX TAP BOLT- 1/2 X 1.75 NC GR5 PL	2	
21	522619	BLADE KIT: 6 L.H. 3 R.H.	1	

O.L. - OBTAIN LOCALLY

SERIAL NUMBER RANGE

- 1 - TDR15B UP TO SN# 1415130
- TDR12B UP TO SN#1312035
- 2 - TDR15B SN#1415131 & UP
- TDR15D - ALL
- TDR12B SN#1312036 & UP
- TDR12D - ALL

## 1.2 Blade Spindle Assembly – Maintenance Free

TDR 15 Serial # 1415137 & up

TDR 12 Serial # 1412038 & up

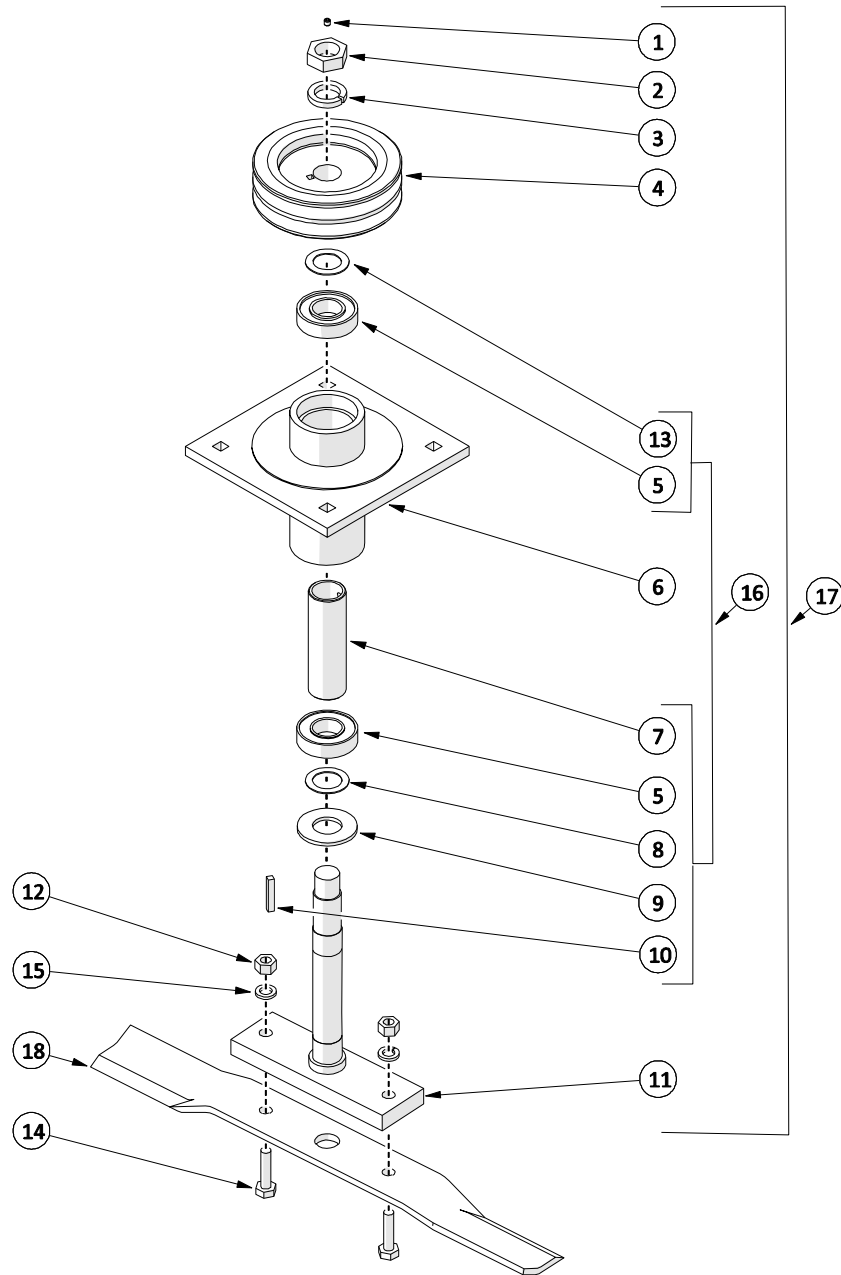

ITEM	PART #	DESCRIPTION	QTY
1	O.L.	SET SCREW - 1/4-28 X 1/4	1
2	521003	HEX NUT- L.H.	1
3	521002	LOCKWASHER L.H. (3 PCS)	1
4	521790	PULLEY - 5.9"	1
5	-	BEARING - SEALED	2
6	524220	SPINDLE HOUSING	1
7	-	SPINDLE SPACER TUBE	1
8	-	SHIM WASHER 1.188"	1
9	-	SPINDLE DIRT SHIELD	1
10	O.L.	KEY - SPINDLE - 1/4" X 1-9/16"	1

ITEM	PART #	DESCRIPTION	QTY
11	524224	BLADE SPINDLE W/ SET SCREW	1
12	O.L.	HEX NUT - 1/2NC GR5 PL	2
13	-	1.125" SHIM WASHER	1
14	O.L.	HEX BOLT- 1/2 X 1.75 NC GR5 PL	2
15	O.L.	LOCK WASHER- 1/2 PL	2
16	524400	SPINDLE REBUILD KIT	1
17	524332	BLADE SPINDLE ASSY	1
18	522619	BLADE KIT: 6 L.H. 3 R.H.	1

O.L. - OBTAIN LOCALLY

# 1.3 Deck Assembly – TDR 15 Wing & Rear (All)

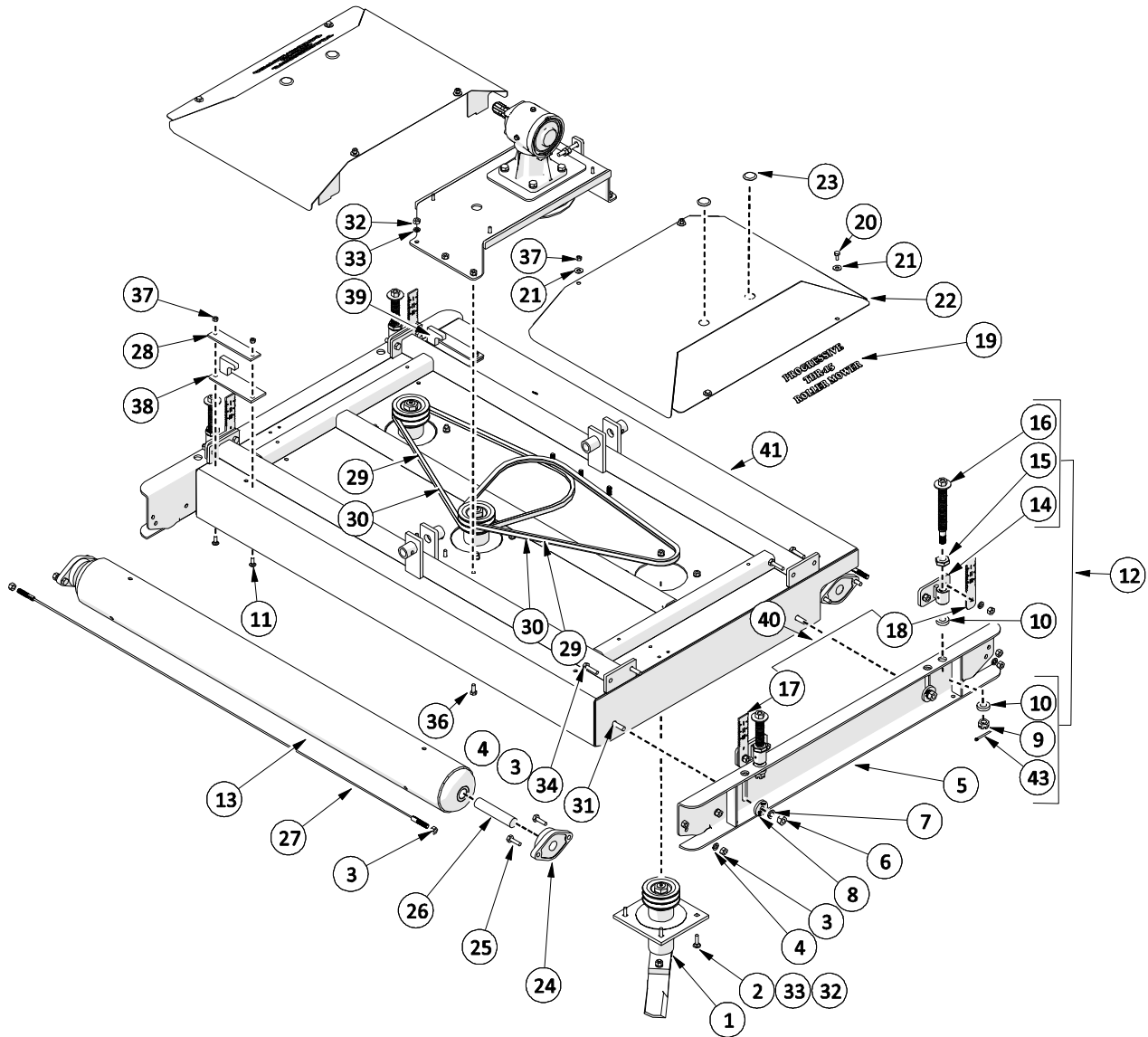

ITEM	PART #	DESCRIPTION	QTY	SN
1	SEE SECT. 1.1/1.2	BLADE SPINDLE ASSEMBLY	3	
2	O.L.	CARR. BOLT- 7/16 X 1.5 NC GR5 PL	12	
3	O.L.	HEX NUT - 1/2NC GR5 PL	24	
4	O.L.	LOCK WASHER- 1/2 PL	16	
5	524190	DECK CHANNEL	2	
6	O.L.	HEX NUT - 5/8NC GR5 PL	4	
7	O.L.	LOCK WASHER- 5/8 PL	4	
8	526148	TDR CLAMP WASHER KIT (4 PCS)	1	
9	-	3/4-10 CASTELLATED NUT PL	4	
10	607580	HEIGHT ADJ. BUSHING KIT (8 PCS)	8	
11	O.L.	CARR. BOLT- 3/8 X 1 NC GR5 PL	4	
12	526252	TDR HEIGHT ADJUSTMENT KIT	1	
13	524216	DECK ROLLER WITH SHAFTS TDR15	2	
14	526340	DECK ADJUSTMENT BRACKET	4	
15	-	ACME JAM NUT - PL	4	
16	-	ACME HEIGHT ADJ. ROD	4	
17	527395	HEIGHT INDICATOR PLATE - FRONT	2	
18	527397	HEIGHT INDICATOR PLATE - REAR	2	
19	209127	TDR-15 ROLLER MOWER DECAL	2	
20	O.L.	HEX BOLT- 3/8 X 0.75 NC GR5 PL	4	
21	O.L.	FLAT WASHER- 3/8 PL	8	

ITEM	PART #	DESCRIPTION	QTY	SN
22	524154	TDR-15 DECK SHIELD	2	
23	526492	SNAP IN PLUG KIT (12 PC KIT)	1	
24	213019	2 BOLT- FLANGE BEARING 1 1/4"	4	
25	O.L.	HEX BOLT- 1/2 X 1.5 NC GR5 PL	8	
26	526494	ROLLER SHAFT REPLACEMENT KIT	4	
27	524221	TDR15 ROLLER WIPER ASSEMBLY	2	
28	528557	DECK STANDOFF PAD - WING DECKS ONLY	2	
29	212039	BELT - B74	2	1
30	521315	BELT - B69	2	2
31	O.L.	CARR. BOLT- 5/8 X 2 NC GR5 PL	4	
32	O.L.	HEX NUT - 7/16NC GR5 PL	18	
33	O.L.	LOCK WASHER- 7/16 PL	18	
34	O.L.	HEX BOLT- 1/2 X 1.75 NC GR5 PL	8	
36	O.L.	HEX BOLT 7/16 X 1 NC GR5 PL	6	
37	O.L.	HEX LOCK NUT - 3/8 PL NC	8	
38	528386	DECK LOCK MOUNT - LEFT - WING DECKS ONLY	1	
39	528382	DECK LOCK MOUNT - RIGHT - WING DECKS ONLY	1	
40	527606	TDR HEIGHT PLATE KIT (4 PCS)	1	
41	524178	MOWER DECK	1	
43	O.L.	3/16 X 1-1/2" COTTER PIN	4	

O.L. - OBTAIN LOCALLY

SERIAL NUMBER RANGE

- 1 - TDR15B SN#1415131 & UP  
TDR12B SN#1312036 & UP  
ALL TDR15D  
ALL TDR12D
- 2 - TDR15B UP TO SN#1415130  
TDR12B UP TO SN#132035

# 1.4 Wing Deck Assembly – TDR-12

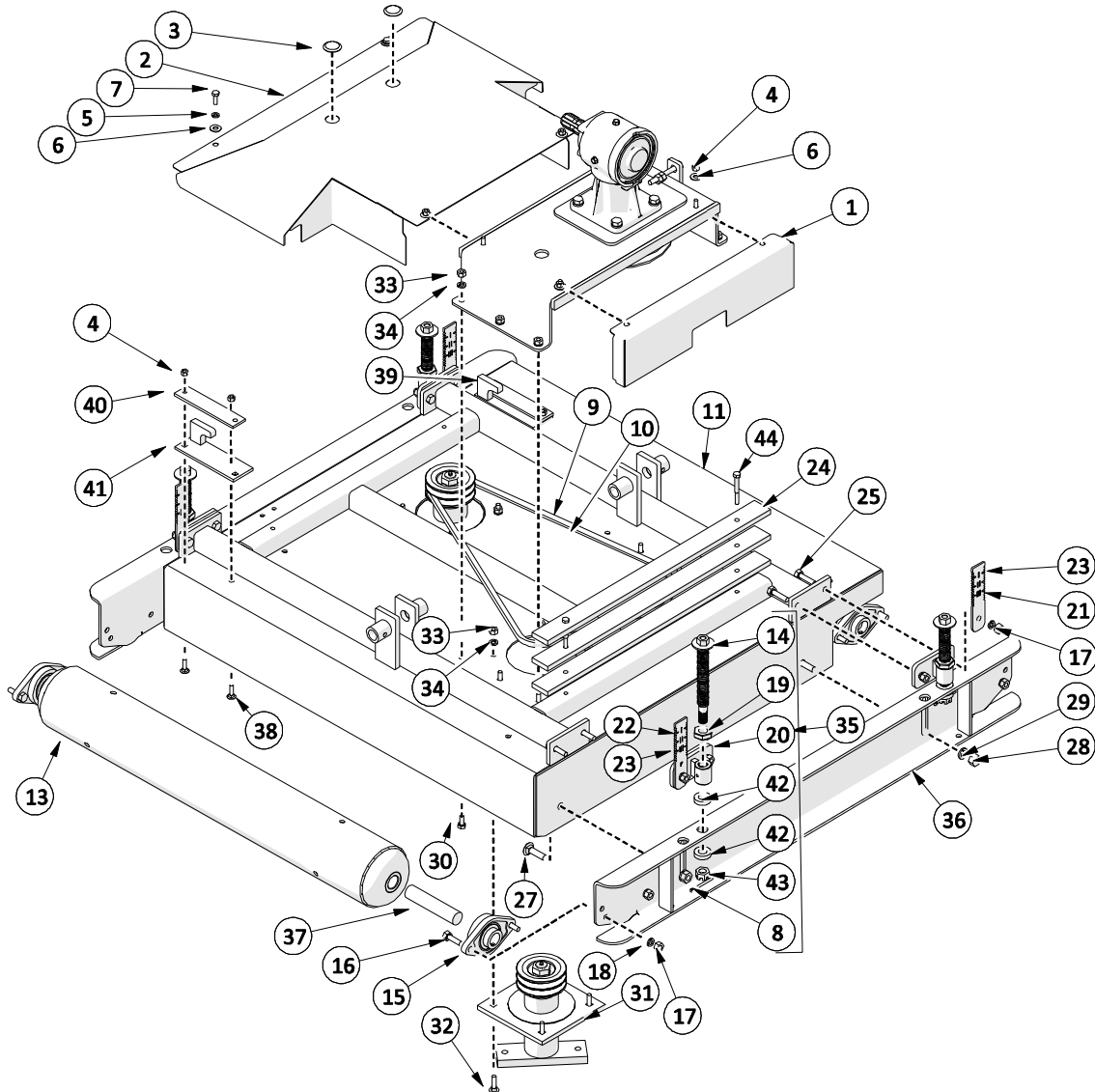

ITEM	PART #	DESCRIPTION	QTY	SN
1	528222	TDR-12 DECK SHIELD - SIDE	1	
2	528212	TDR-12 DECK SHIELD	1	
3	526492	SNAP IN PLUG KIT (12 PC)	1	
4	O.L.	HEX LOCK NUT - 3/8NC GR5 PL	8	
5	O.L.	LOCK WASHER- 3/8 PL	2	
6	O.L.	FLAT WASHER- 3/8 PL	6	
7	O.L.	HEX BOLT- 3/8 X 1 NC GR5 PL	2	
8	O.L.	5/32 X 1-1/2" COTTER PIN	4	
9	212039	BELT - B74	1	1
10	521315	BELT - B69	1	2
11	528214	WING DECK - L.H. (SHOWN)	1	
12	528204	WING DECK - R.H.	1	
13	528206	DECK ROLLER WITH SHAFTS	2	
14	-	ACME HEIGHT ADJ. ROD	4	
15	213019	FLANGE BEARING - 2 BOLT	4	
16	O.L.	HEX BOLT- 1/2 X 1.5 NC GR5 PL	8	
17	O.L.	HEX NUT - 1/2NC GR5 PL	16	
18	O.L.	LOCK WASHER- 1/2 PL	8	
19	-	ACME JAM NUT - PL	4	
20	526340	DECK ADJUSTMENT BRACKET	4	
21	527397	HEIGHT INDICATOR PLATE - REAR	2	
22	527395	HEIGHT INDICATOR PLATE - FRONT	2	

ITEM	PART #	DESCRIPTION	QTY	SN
23	527606	HEIGHT PLATE KIT (4 PCS)	1	
24	528667	WEIGHT PLATE	3	
25	O.L.	HEX BOLT- 1/2 X 1.75 NC GR5 PL	8	
27	O.L.	CARR. BOLT- 5/8 X 2 NC GR5 PL	4	
28	O.L.	HEX NUT - 5/8NC GR5 PL	4	
29	O.L.	LOCK WASHER- 5/8 PL	4	
30	O.L.	HEX BOLT- 7/16 X 1 NC GR5 PL	6	
31	SEE SECT. 1.1/1.2	BLADE SPINDLE ASSY	2	
32	O.L.	CARR. BOLT- 7/16 X 1.5 NC GR5 PL	8	
33	O.L.	HEX NUT - 7/16NC GR5 PL	14	
34	O.L.	LOCK WASHER- 7/16 PL	14	
35	526252	TDR HEIGHT ADJUSTMENT KIT	1	
36	524190	DECK CHANNEL	2	
37	526494	ROLLER SHAFT REPLACEMENT KIT	4	
38	O.L.	CARR. BOLT- 3/8 X 1	4	
39	528382	DECK LOCK MOUNT - RIGHT	1	
40	528557	DECK STANDOFF PAD	2	
41	528386	DECK LOCK MOUNT - LEFT	1	
42	607580	HEIGHT ADJ. BUSHING KIT (8 PCS)	8	
43	305715	3/4-10 CASTELLATED NUT PL	4	
44	O.L.	HEX BOLT- 3/8 X 3 NC GR5 PL	2	

O.L. - OBTAIN LOCALLY

SERIAL NUMBER RANGE

1 - TDR12B SN#1312036 & UP  
 ALL TDR12D  
 2 - TDR12B UP TO SN#132035

# 1.5 Gearbox Assembly

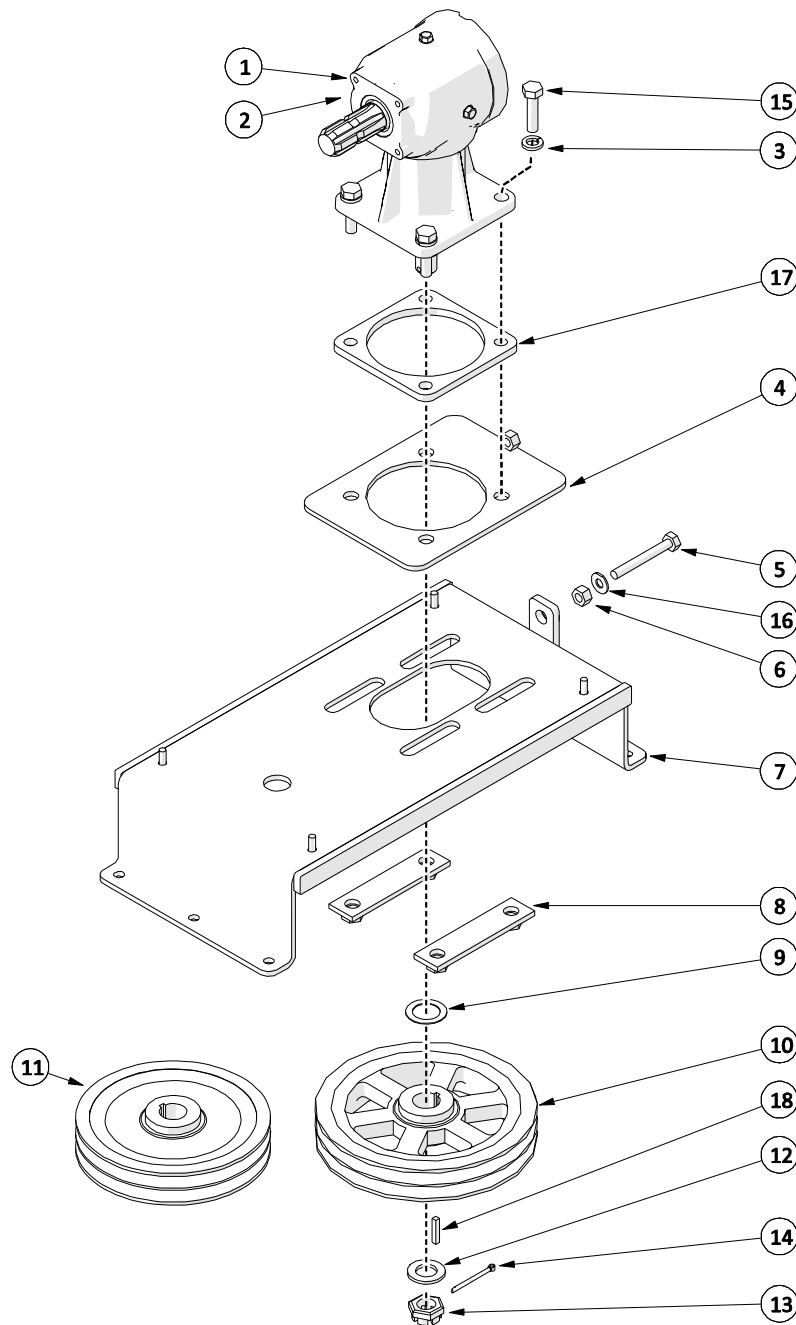

ITEM	PART #	DESCRIPTION	QTY	SN
1	521012	GEAR BOX - RH WING/REAR	1	
2	521033	GEAR BOX - LH WING	1	
3	O.L.	LOCK WASHER- 9/16 PL	4	
4	521013	SLIDE PLATE	1	
5	521020	HEX TAP BOLT-5/8" X 3.00 (3 PC KIT)	1	
6	O.L.	HEX NUT - 1/2NC GR5 PL	1	
7	521019	GEARBOX MOUNT	1	
8	521018	STIFFENER NUT BRACKET	2	
9	521004	SHIM WASHER - 1.25 (9 PCS)	1	
10	212021	DRIVE PULLEY - 10.00"	1	1

ITEM	PART #	DESCRIPTION	QTY	SN
11	521774	DRIVE PULLEY - 8.7"	1	2
12	521129	WASHER 25 X 44 X 4 (3 PCS)	1	
13	521130	CASTLE NUT M24	1	
14	O.L.	COTTER PIN - 3/16 X 1-1/2	1	
15	O.L.	HEX BOLT- 9/16 X 2.25 NC GR5 PL	4	
16	O.L.	FLAT WASHER- 1/2 PL	1	
17	528657	GEAR BOX SPACER PLATE	1	
18	521390	KEY - 1/4 X 1 5/16 (3 PCS) KIT	1	

O.L. - OBTAIN LOCALLY

SERIAL NUMBER RANGE

1 - TDR15B SN#1415131 & UP  
 TDR12B SN#1312036 & UP  
 TDR15D - ALL  
 TDR12D - ALL  
 2 - TDR15B UP TO SN# 1415130  
 TDR12B UP TO SN#1312035

## 2 FRAME ASSEMBLY

### 2.1 Frame Assembly

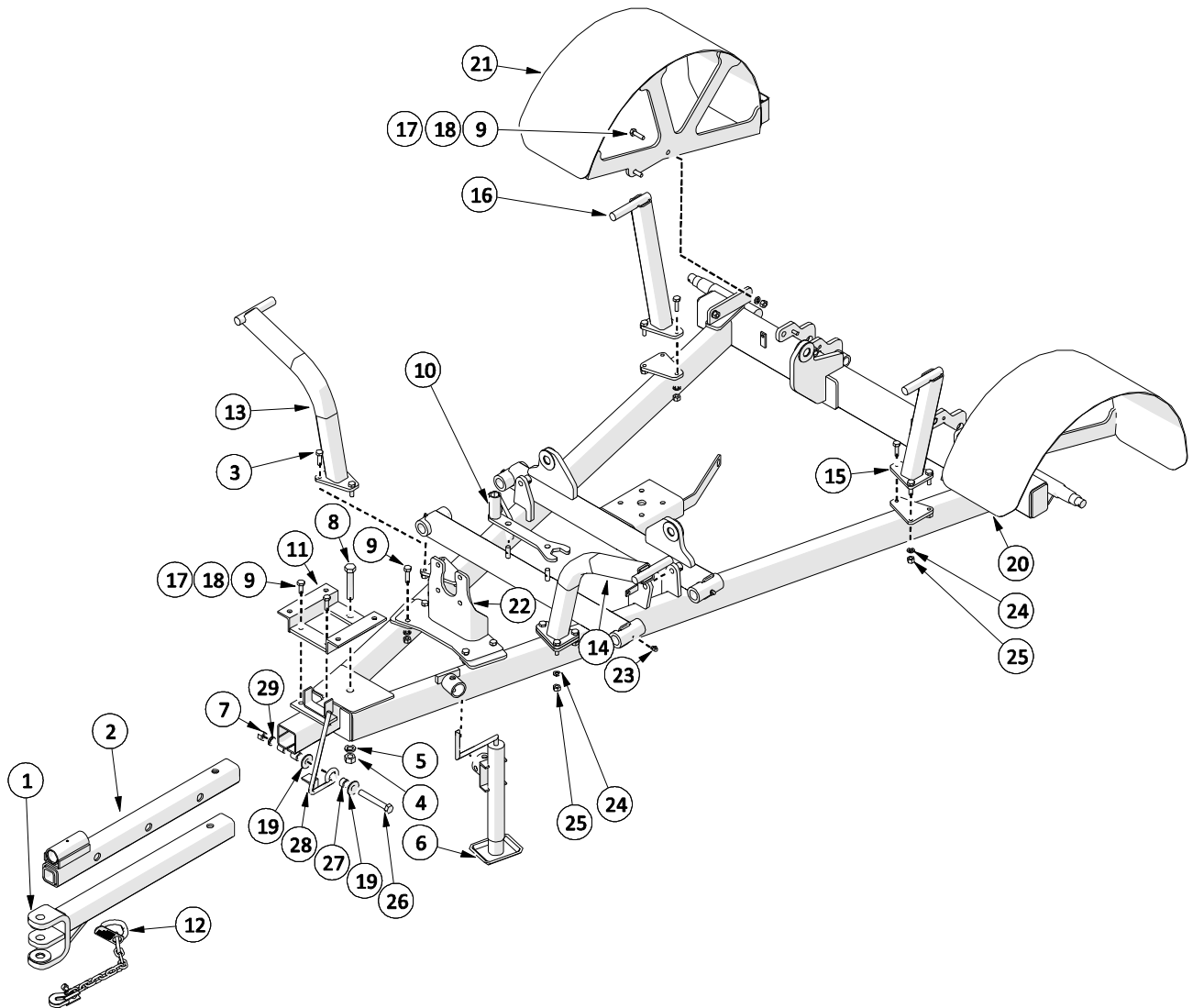

ITEM	PART #	DESCRIPTION	QTY
1	521322	4 POSITION HITCH	1
2	528428	PINTLE HITCH - D MODEL	1
3	O.L.	HEX BOLT - 3/8 X 1-1/4 NC GR5 PL	12
4	O.L.	HEX NUT - 3/4NC GR5 PL	1
5	O.L.	LOCK WASHER- 3/4 PL	1
6	219005	IMPLEMENT JACK	1
7	O.L.	HEX NUT - 5/8NC GR5 PL	1
8	O.L.	HEX BOLT- 3/4 X 5 NC GR5 PL	1
9	O.L.	HEX BOLT - 1/2 X 1.5 NC GR5 PL	10
10	526094	HEIGHT ADJUSTMENT WRENCH	1
11	528292	FRONT SHIELD MOUNT	1
12	521048	SAFETY CHAIN	1
13	528380	FRONT STANDOFF- R.H.	1
14	528434	FRONT STANDOFF- L.H.	1
15	528436	REAR STANDOFF- L.H.	1

ITEM	PART #	DESCRIPTION	QTY
16	528384	REAR STANDOFF- R.H.	1
17	O.L.	HEX NUT - 1/2 NC GR5 PL	10
18	O.L.	LOCK WASHER- 1/2 PL	10
19	O.L.	FLAT WASHER- 5/8 PL	2
20	528154	REAR LEFT FENDER (D MODELS)	1
21	528152	REAR RIGHT FENDER (D MODELS)	1
22	528396	INTERMEDIATE BEARING SUPPORT	1
23	O.L.	GREASE FITTING 90 DEG	4
24	O.L.	LOCKWASHER - 3/8 PL	12
25	O.L.	HEX NUT - 3/8" NC GR5 PL	12
26	O.L.	HEX BOLT- 5/8 X 4.5 NC GR5 PL	1
27	528553	PTO SUPPORT BUSHING	1
28	528550	PTO SUPPORT	1
29	O.L.	LOCK WASHER- 5/8 PL	1

O.L. - OBTAIN LOCALLY

## 2.2 Lift Assembly

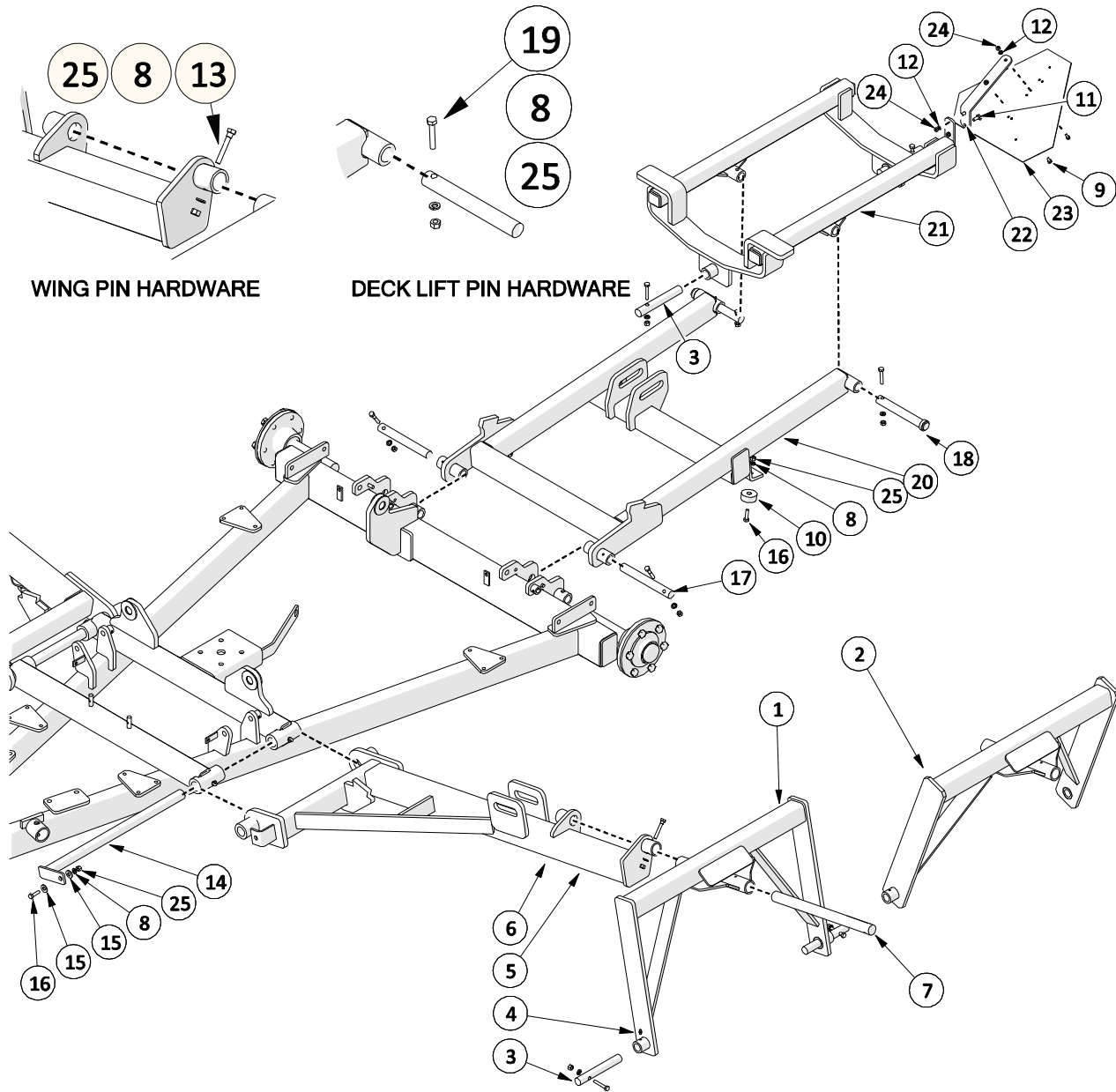

ITEM	PART #	DESCRIPTION	QTY
1	528114	DECK SWIVEL - TDR 15	2
2	528210	DECK SWIVEL - TDR 12	2
3	521337	DECK LIFT PIN	6
4	522020	GREASE FITTING KIT (20 PCS)	5
5	528390	WING - L.H. (SHOWN)	1
6	528232	WING - R.H.	1
7	521338	SWIVEL PIN	2
8	O.L.	LOCKWASHER - 3/8 PL	16
9	O.L.	HEX BOLT - 5/16 X 0.75 NC GR5 PL	2
10	528275	STANDOFF BUMPER	2
11	O.L.	HEX BOLT - 5/16 X 0.75 NC GR5 PL	2
12	O.L.	LOCK WASHER - 5/16 PL	4
13	O.L.	HEX BOLT - 3/8 X 2.25 NC GR5 PL	2

ITEM	PART #	DESCRIPTION	QTY
14	523155	WING PIN 23"	2
15	O.L.	FLAT WASHER - 3/8 PL	4
16	O.L.	HEX BOLT - 3/8 X 1.25 NC GR5 PL	4
17	526445	PULL TUBE FRAME PIN	2
18	526254	REAR SWIVEL PIN SHAFT	2
19	O.L.	HEX BOLT - 3/8 X 2 NC GR5 PL	10
20	528388	REAR LIFT FRAME	1
21	524168	TDR-15' REAR SWIVEL	1
22	528335	SMV BRACKET	1
23	521353	SMV SIGN	1
24	O.L.	HEX NUT - 5/16NC GR5 PL	4
25	O.L.	HEX NUT - 3/8NC GR5 PL	16

O.L. - OBTAIN LOCALLY

## 2.3 Wing Lock Assemblies

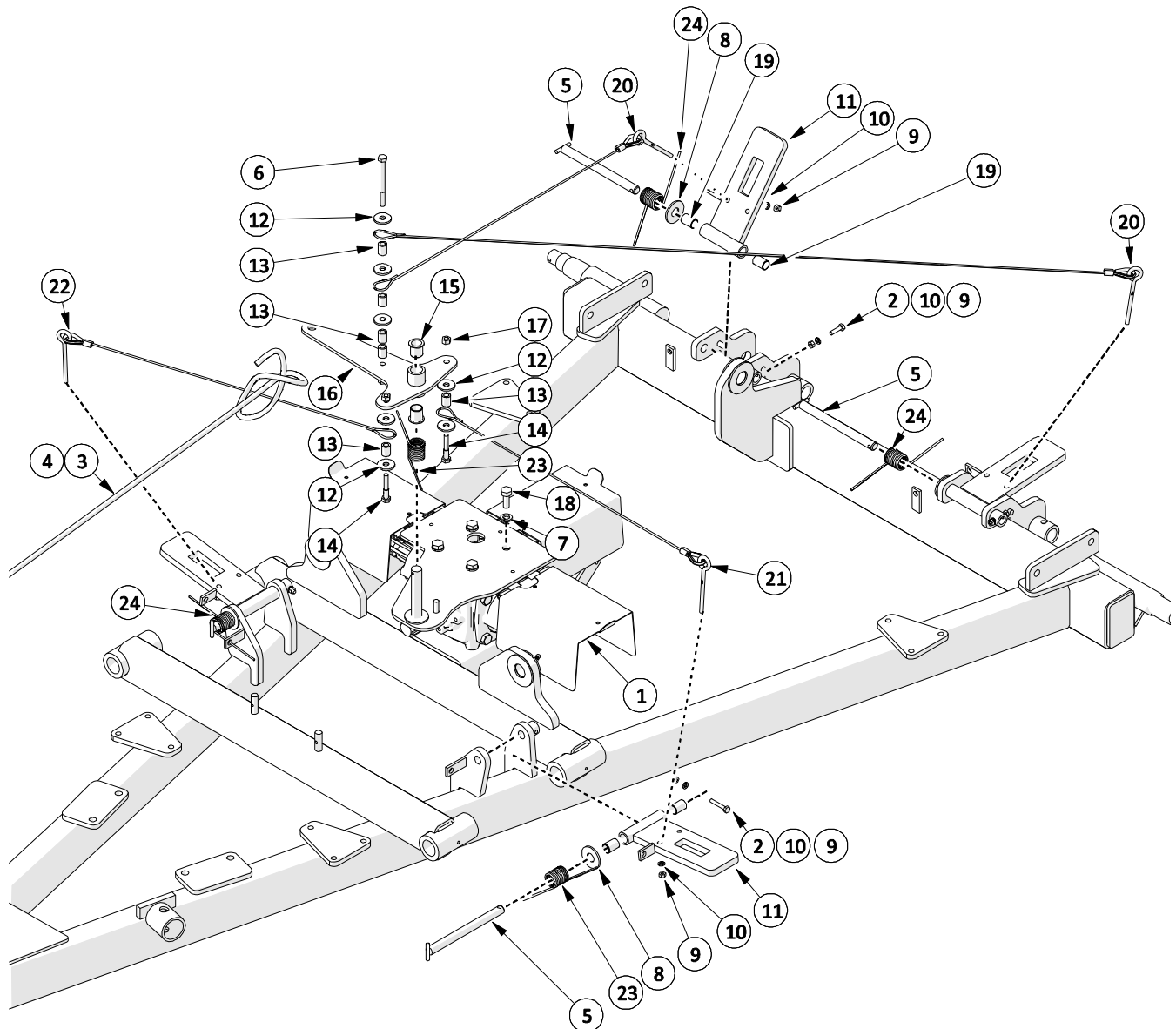

ITEM	PART #	DESCRIPTION	QTY
1	528374	4-WAY GEARBOX SHIELD	1
2	O.L.	HEX BOLT - 1/4 x 1.5 NC GR5 PL	4
3	521331	PULL ROPE - 10'	1
4	O.L.	S HOOK - 2.5"	1
5	528442	LOCK PIN	4
6	O.L.	HEX BOLT- 3/8 X 4.50 NC GR5 PL	1
7	O.L.	LOCK WASHER- 1/2 PL	4
8	O.L.	FLAT WASHER- 5/8 PL	4
9	O.L.	HEX NUT - 1/4NC GR5 PL	8
10	O.L.	LOCK WASHER- 1/4 PL	8
11	528372	WING LOCK	4
12	O.L.	FENDER WASHER- 3/8 PL 1.25 O.D.	7
13	600053	WING LATCH BUSHING	6

ITEM	PART #	DESCRIPTION	QTY
14	O.L.	HEX BOLT- 3/8 X 1.75 NC GR5 PL	2
15	527349	FLANGE BEARING KIT - (2 PCS)	2
16	528376	LOCK RELEASE SWIVEL	1
17	O.L.	HEX NUT - 3/8" NC GR5 PL	3
18	O.L.	HEX BOLT- M12 X 30MM NC GR5 PL	4
19	606500	SLEEVE BEARING 5/8" - 10 PC KIT	8
20	528770	LOCK RELEASE CABLE - REAR	2
21	528766	LOCK RELEASE CABLE - LEFT	1
22	528768	LOCK RELEASE CABLE - RIGHT	1
23	527247	WING LOCK SPRING L.H. WIND	2
24	527245	WING LOCK SPRING R.H. WIND	3

O.L. - OBTAIN LOCALLY

## 2.4 Wheel Assemblies

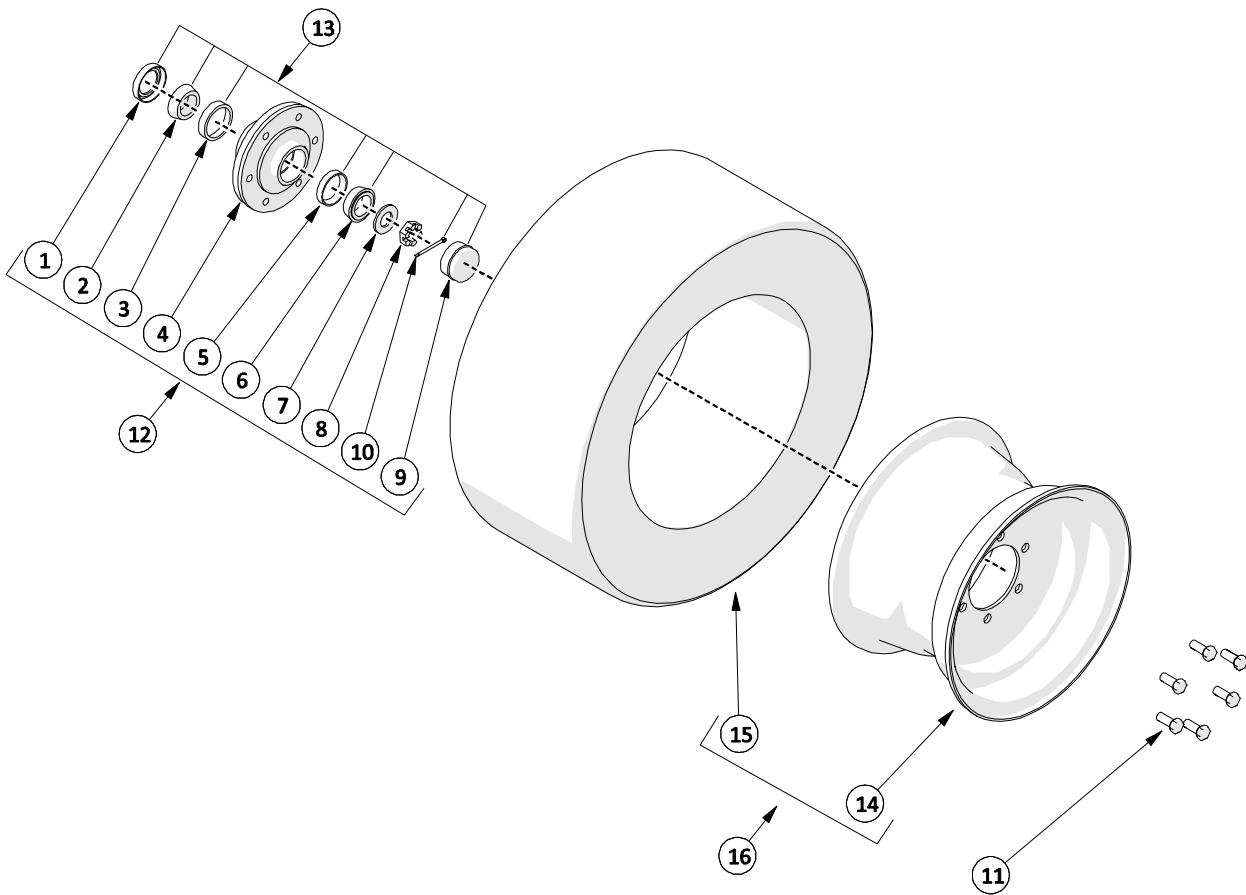

ITEM	PART #	DESCRIPTION	QTY
1	521741	GREASE SEAL	1
2	-	BEARING - INNER	1
3	-	BEARING RACE - INNER	1
4	-	HUB	1
5	-	BEARING RACE - OUTER	1
6	-	BEARING - INSIDE	1
7	521761	WASHER (2 PCS)	1
8	521747	CASTELLATED NUT - 4000#(2 PCS)	1
9	521762	DUST CAP	1
10	O.L.	3/16 X 1-1/2" COTTER PIN	1
11	521083	WHEEL STUD KIT (6 PCS)	1
12	521085	HUB ASSEMBLY - COMPLETE	1
13	521046	BEARING KIT - WHEEL	1
14	521084R	RIM - 15 X 10 - 6 BOLT	1
15	O.L.	TIRE - P275/60 R15	1
16	521084	TIRE & RIM - P275/60 R15	1

# 3 HYDRAULICS

## 3.1 Hydraulics

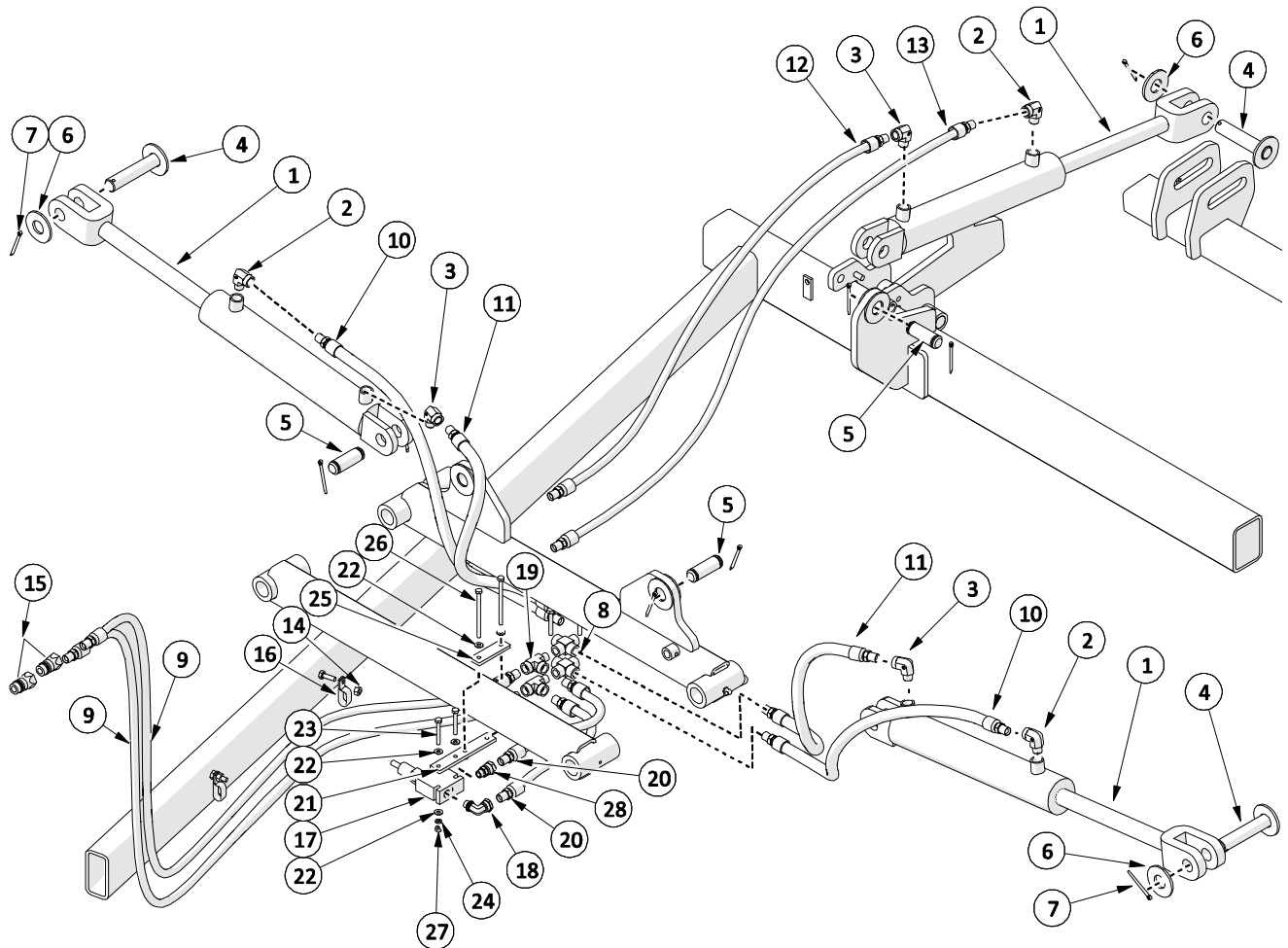

ITEM	PART #	DESCRIPTION	QTY	SN
1	522300	HYDRAULIC CYLINDER	3	
2	521336	RESTRICTOR FITTING 90	3	
3	222017	90 DEG ELBOW	3	
4	521103	WING CYLINDER PIN	3	
5	521345	PIN - 1" X 2.938"	3	
6	O.L.	FLAT WASHER- 1 PL	3	
7	521752	COTTER PIN (6 PCS)	2	
8	521070	HYDRAULIC CROSS	2	
9	521334	HYDRAULIC HOSE - 122"	2	
10	528760	HYDRAULIC HOSE - 34"	2	
11	528774	HYDRAULIC HOSE - 21-1/4"	2	
12	528764	HYDRAULIC HOSE - 46-1/4"	1	
13	528772	HYDRAULIC HOSE - 64-1/4"	1	
14	O.L.	HEX LOCK NUT - 3/8 NC GR5 PL	2	
15	222006	HOSE END KIT (2 PCS)	1	

ITEM	PART #	DESCRIPTION	QTY	SN
16	229008	5/8 DOUBLE TUBE CLAMP	2	
17	528822	RELIEF VALVE - 1000PSI	1	1
18	221099	90 EL ADAPT -6ORB X -6NPT SWVL	1	1
19	521076	STREET TEE 3/8 NPT MXFXF	2	1
20	221101	HOSE ASSY - 19"	2	1
21	528375	MTG PLATE - RELIEF VALVE	1	1
22	O.L.	FLAT WASHER- 1/4 PL	8	1
23	O.L.	HEX BOLT - 1/4 X 2.0 NC GR5 PL	2	1
24	O.L.	LOCKWASHER - 1/4 PL	4	1
25	528373	CLAMP PLATE - VALVE MOUNT	1	1
26	O.L.	HEX BOLT - 1/4 x 4.0 NC GR5 PL	2	1
27	O.L.	HEX NUT - 1/4NC GR5 PL	4	1
28	221100	STR ADAPTER -6ORB X -6NPT SWVL	1	1

O.L. - OBTAIN LOCALLY

SERIAL NUMBER RANGE

1 - TDR15 S#1415134D & UP  
TDR12 S#1412035B & UP

# 4 DRIVELINE

## 4.1 Driveline

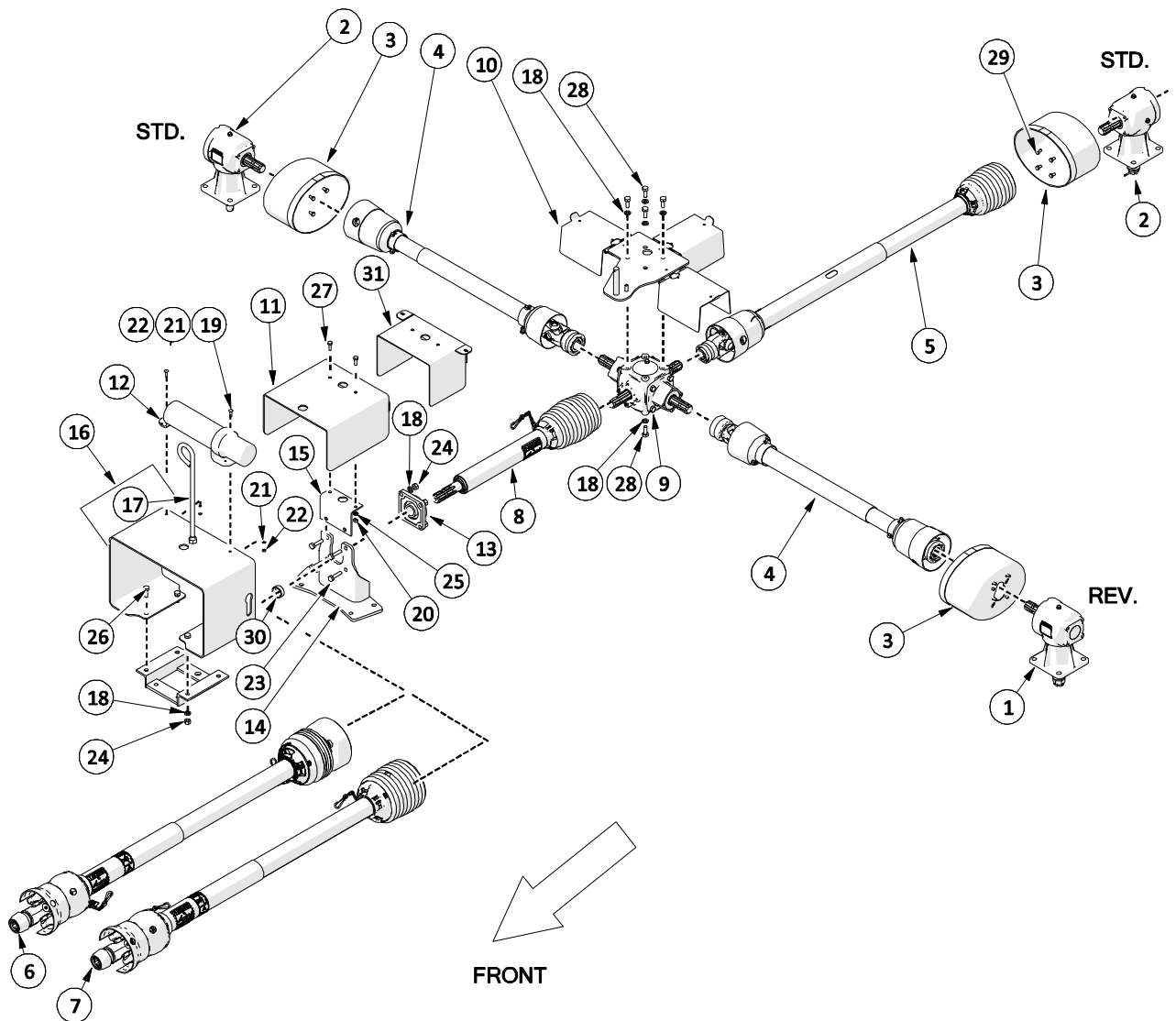

ITEM	PART #	DESCRIPTION	QTY
1	SEE SECT. 4.8	GEARBOX - REV. ROTATION	1
2	SEE SECT. 4.7	GEARBOX - STD. ROTATION	2
3	210061	COUNTER CONE	3
4	521718	PTO SHAFT - WING DECK	2
5	210190	PTO SHAFT - REAR DECK	1
6	210290	INPUT PTO - TDR 15 D MODEL ONLY	1
7	210280	INPUT PTO - B MODEL	1
8	210210	INTERMEDIATE PTO	1
9	521497	GEAR BOX - 4 SHAFT	1
10	528374	4-WAY GEARBOX SHIELD	1
11	528194	INTERMEDIATE SHIELD (D MODEL)	1
12	120519	MANUAL HOLDER TUBE	1
13	521323	4 BOLT FLANGE BEARING - 1-3/8"	1
14	528396	INTERMEDIATE BEARING SUPPORT	1
15	528439	INTERMEDIATE SHIELD BRACKET	1
16	522708	HOSE SUPPORT & SHIELD	1

ITEM	PART #	DESCRIPTION	QTY
17	522413	HOSE GUIDE - C/W HARDWARE	1
18	O.L.	LOCK WASHER - 1/2 PL	16
19	O.L.	CARR BOLT - 1/4 X 1 NC GR5 PL	2
20	O.L.	HEX NUT - 3/8NC GR5 PL	2
21	O.L.	LOCK WASHER - 1/4 PL	2
22	O.L.	HEX NUT - 1/4NC GR5 PL	2
23	O.L.	HEX BOLT - 1/2 X 1.75 NC GR5 PL	4
24	O.L.	HEX NUT - 1/2NC GR5 PL	8
25	O.L.	LOCK WASHER - 3/8 PL	2
26	O.L.	HEX BOLT - 1/2 X 1.25 NC GR5 PL	4
27	O.L.	HEX BOLT - 3/8 X 1 NC GR5 PL	2
28	521488	HEX BOLT - M12 X 30 (4 PC KIT)	8
29	521399	HEX BOLT - M8 X 14GR 8.8	12
30	521789	PTO SPACER	1
31	600430	INTERMEDIATE SHIELD (B MODEL)	1

O.L. - OBTAIN LOCALLY

## 4.2 Input PTO Shaft

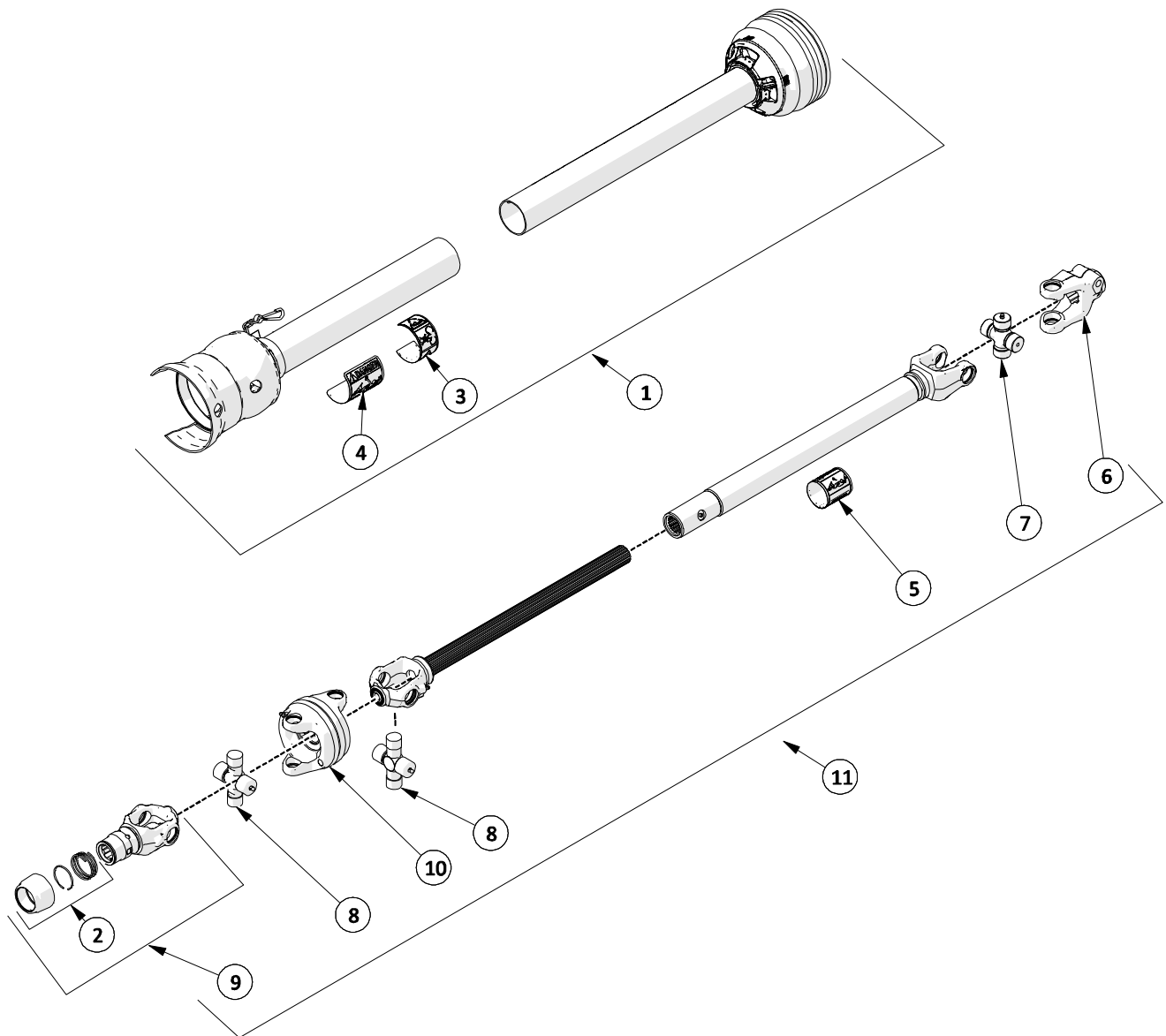

ITEM	PART #	DESCRIPTION	QTY
1	210286	COMPLETE GUARD SET	1
2	210179	SLIDE LOCK REPAIR KIT (44E)	1
3	210238	CE WARNING DECAL	1
4	210237	SAFETY SIGN - OUTER GUARD	1
5	210239	SAFETY SIGN - INNER GUARD	1
6	210235	35 SERIES CLAMP YOKE	1
7	210234	35E2BL CROSS KIT	1
8	210284	CAT 4 80 EBL CROSS & BRG KIT	2
9	210283	AUTO LOK YOKE ASSEMBLY	1
10	210281	CENTER HOUSING	1
11	210280	COMPLETE INPUT PTO SHAFT W/GUARDS	1

### 4.3 Input PTO Shaft – TDR-15 D Model

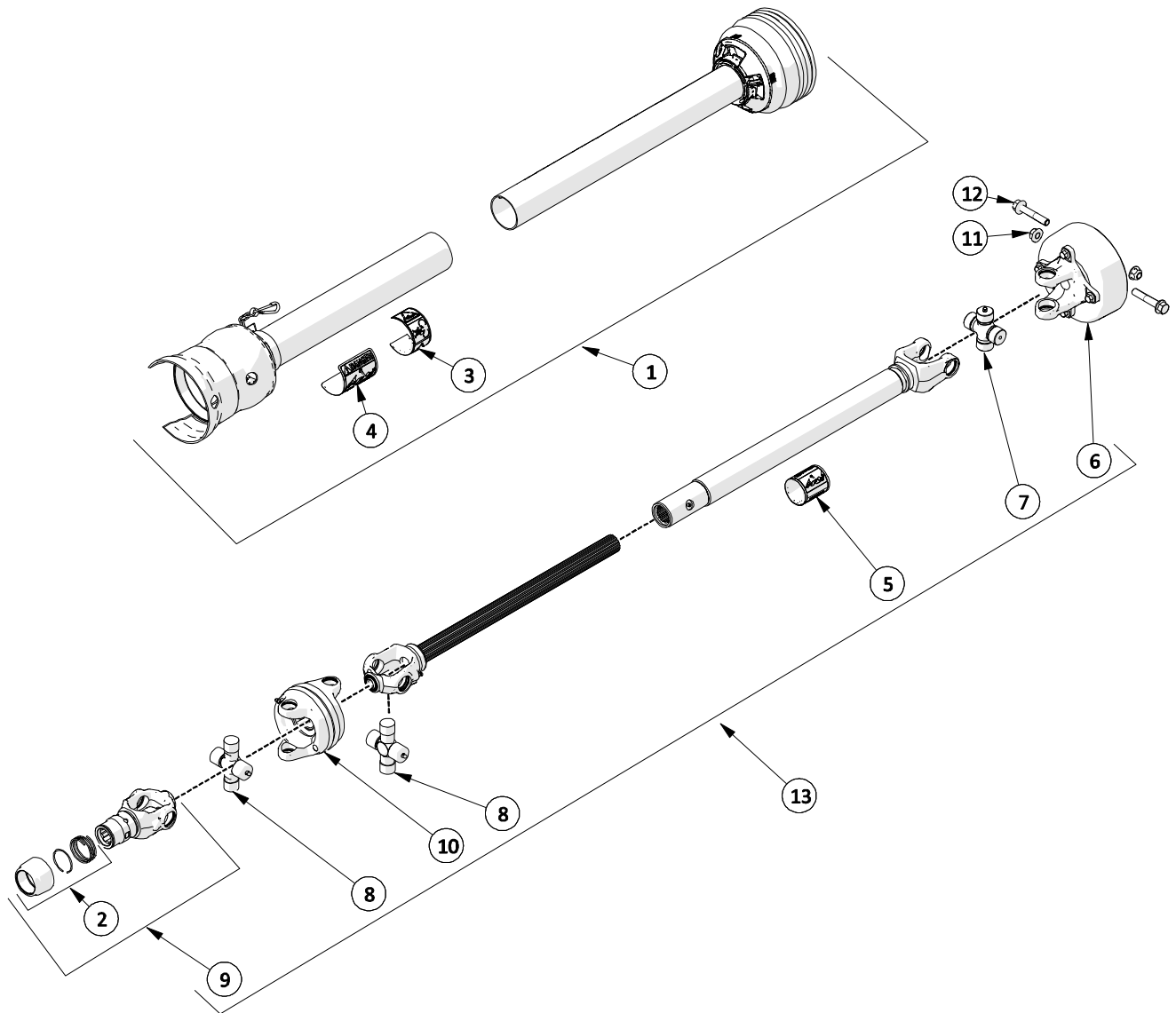

ITEM	PART #	DESCRIPTION	QTY
1	210286	COMPLETE GUARD SET 35E2BL	1
2	210179	SLIDE LOCK REPAIR KIT (44E)	1
3	210238	CE WARNING DECAL	1
4	210237	SAFETY SIGN - OUTER GUARD	1
5	210239	SAFETY SIGN - INNER GUARD	1
6	210257	AUTOMATIC CLUTCH ASSEMBLY	1
7	210234	35E2BL CROSS KIT	1
8	210284	CAT 4 80 EBL CROSS & BRG KIT	2
9	210283	AUTO LOK YOKE ASSEMBLY	1
10	210281	CENTER HOUSING	1
11	O.L.	HEX LOCK NUT - 1/2" NC GR8 PL	2
12	O.L.	HEX BOLT - 1/2 X 2.75" NC GR8 PL	2
13	210290	COMPLETE INPUT PTO SHAFT W/GUARDS	1

O.L. - OBTAIN LOCALLY

## 4.4 Intermediate PTO Shaft

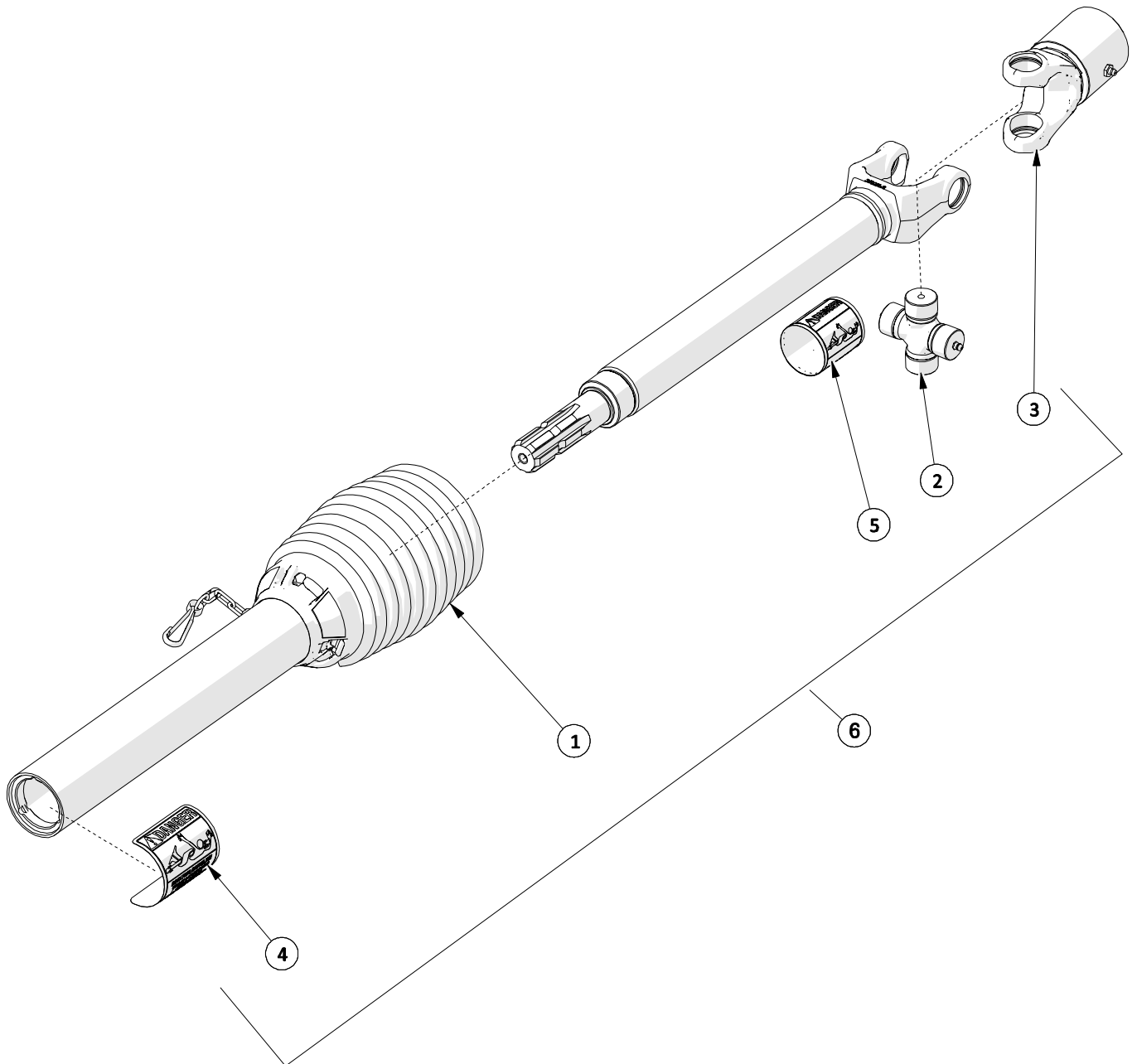

ITEM	PART #	Description	QTY
1	210211	PTO GUARD	1
2	210234	35E2BL CROSS & BEARING KIT	1
3	210212	OVERRUNNING CLUTCH ASSEMBLY	1
4	210237	SAFETY SIGN - OUTER GUARD	1
5	210239	SAFETY SIGN - INNER GUARD	1
6	210210	COMPLETE PTO SHAFT ASSEMBLY	1

## 4.5 Wing Deck PTO Shaft

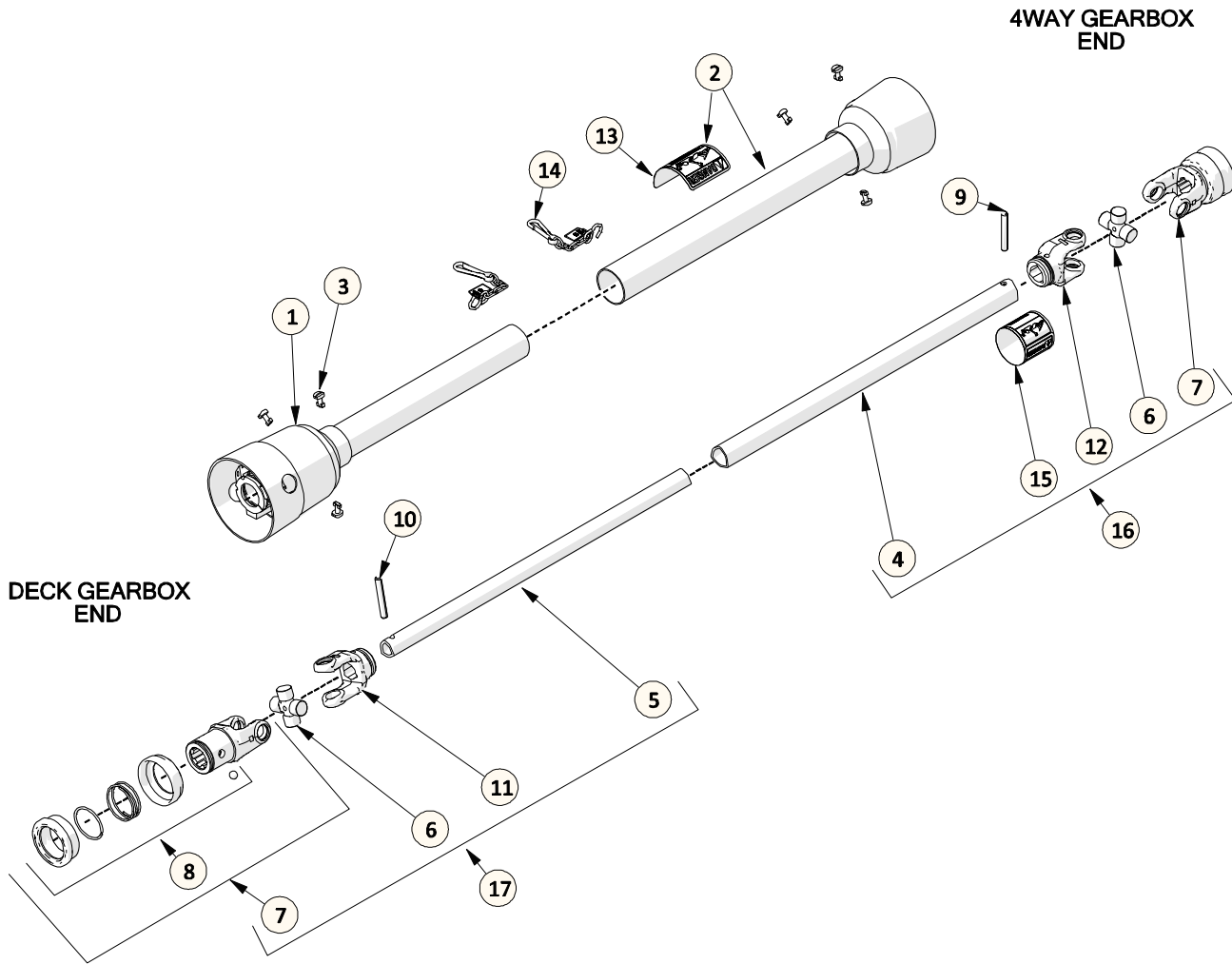

ITEM	PART #	DESCRIPTION	QTY
1	521717	PTO - HALF MALE SHIELD	1
2	521716	PTO - 1/2 FEMALE SHIELD	1
3	521463	PLASTIC SHIELD BOLT - 6 PC KIT	1
4	521712	PTO - OUTER TUBE	1
5	521713	PTO - INNER TUBE	1
6	521779	UNIVERSAL JOINT KIT	2
7	521778	YOKE - QD 6 SPLINE	2
8	210017	SLIDE COLLAR KIT - METALLIC	1
9	521781	ROLL PIN - OUTER TUBE	1
10	521782	ROLL PIN - INNER TUBE	1
11	521783	YOKE - INNER TUBE	1
12	521780	YOKE - OUTER TUBE	1
13	521455	DECAL - DANGER - OUTER SHIELD	1
14	521467	SAFETY CHAIN	2
15	521451	DECAL - DANGER - OUTER TUBE	1
16	521714	PTO - 1/2 SHAFT - FEMALE W/SHIELD	1
17	521715	PTO - 1/2 SHAFT - MALE W/SHIELD	1
18	521718	PTO SHAFT COMPELTE - TD65 DECK	1

## 4.6 Rear Deck PTO Shaft

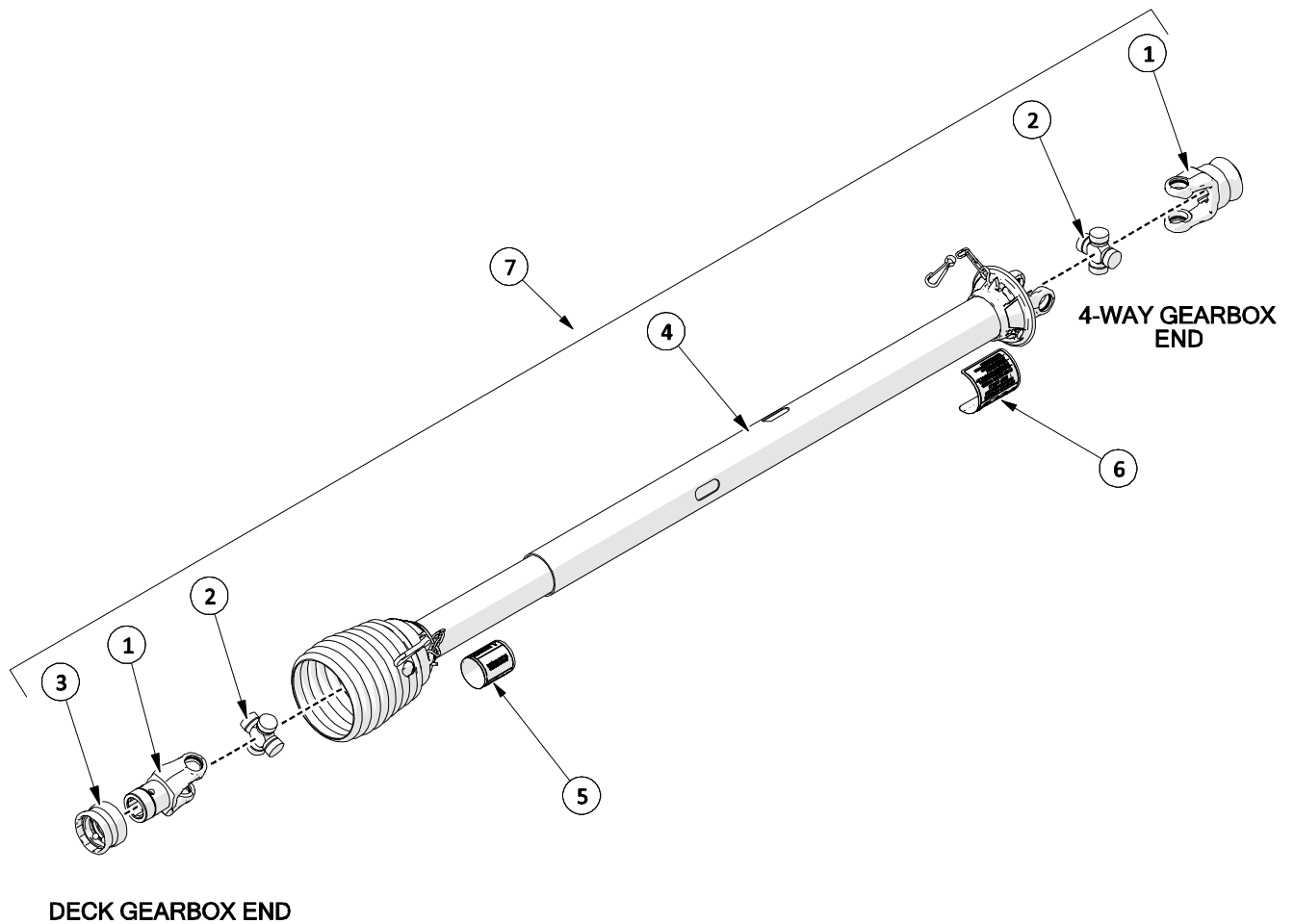

ITEM	PART #	DESCRIPTION	QTY
1	210192	SPRING-LOK YOKE ASSM.	2
2	210191	CROSS AND BEARING KIT	2
3	210196	SPRING-LOK REPAIR KIT	2
4	210195	COMPLETE GUARD SET	1
5	210239	SAFETY SIGN - INNER GUARD	1
6	210237	SAFETY SIGN - OUTER GUARD	1
7	210190	DECK SHAFT - COMPLETE W/GUARDS	1

## 4.7 4 - Way Gearbox

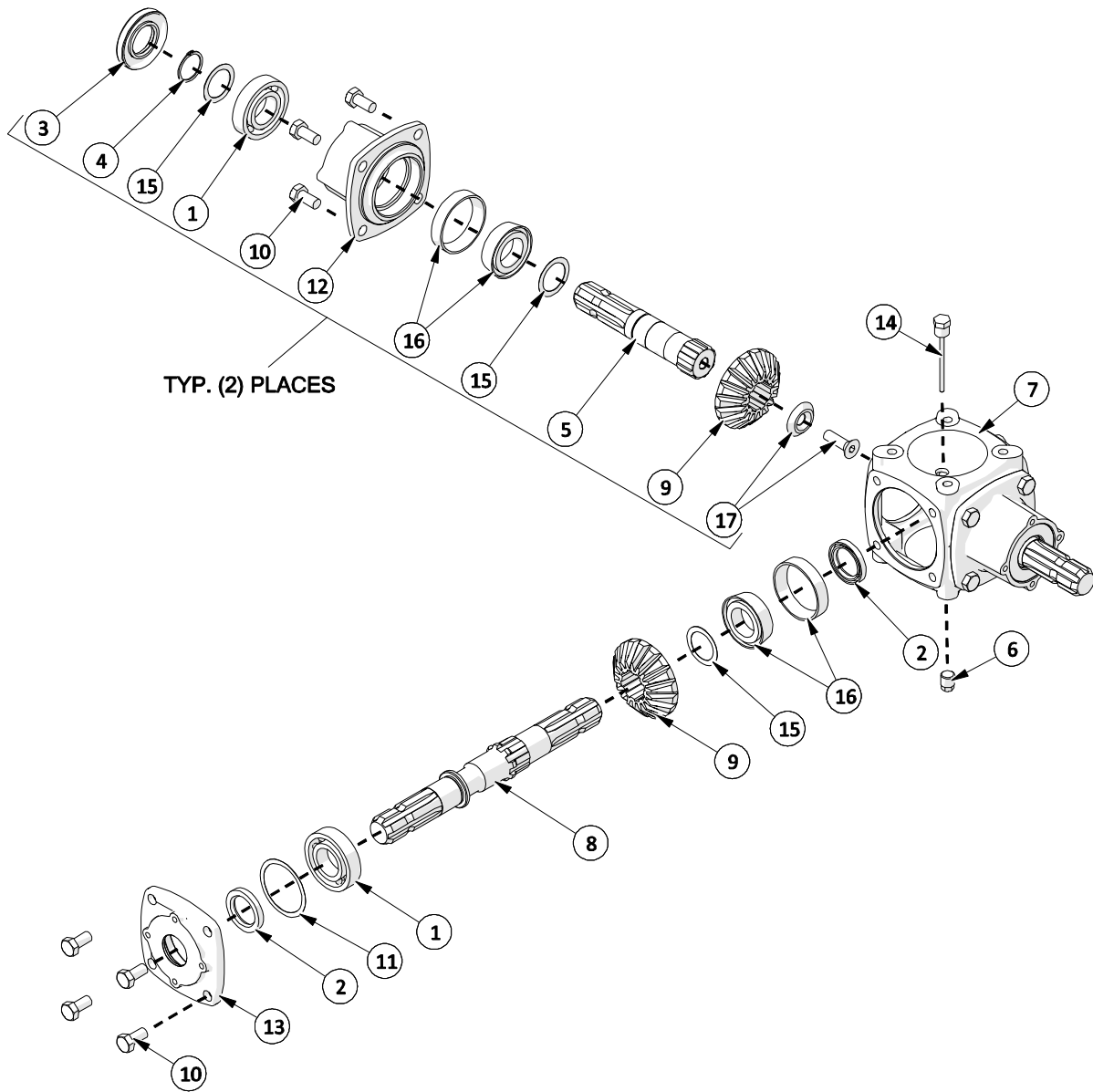

ITEM	PART #	DESCRIPTION	QTY
1	521116	BEARING	3
2	521120	OIL SEAL	2
3	521127	OIL SEAL	2
4	521137	SNAP RING	2
5	521481	STUB SHAFT	2
6	521482	HEX PIPE PLUG	1
7	521483	HOUSING	1
8	521486	THRU SHAFT	1
9	521487	GEAR	3

ITEM	PART #	DESCRIPTION	QTY
10	521488	BOLT - M12 X 25 - 8.8 (6 PCS)	12
11	521491	SHIM KIT	1
12	521796	EXTENSION HOUSING	2
13	521797	COVER	1
14	521489	OIL LEVEL DIPSTICK	1
15	521794	SHIM KIT	5
16	521362	BEARING - TAPERED	2
17	522426	BOLT AND WASHER KIT	1

## 4.8 Deck Gearbox – Standard Rotation

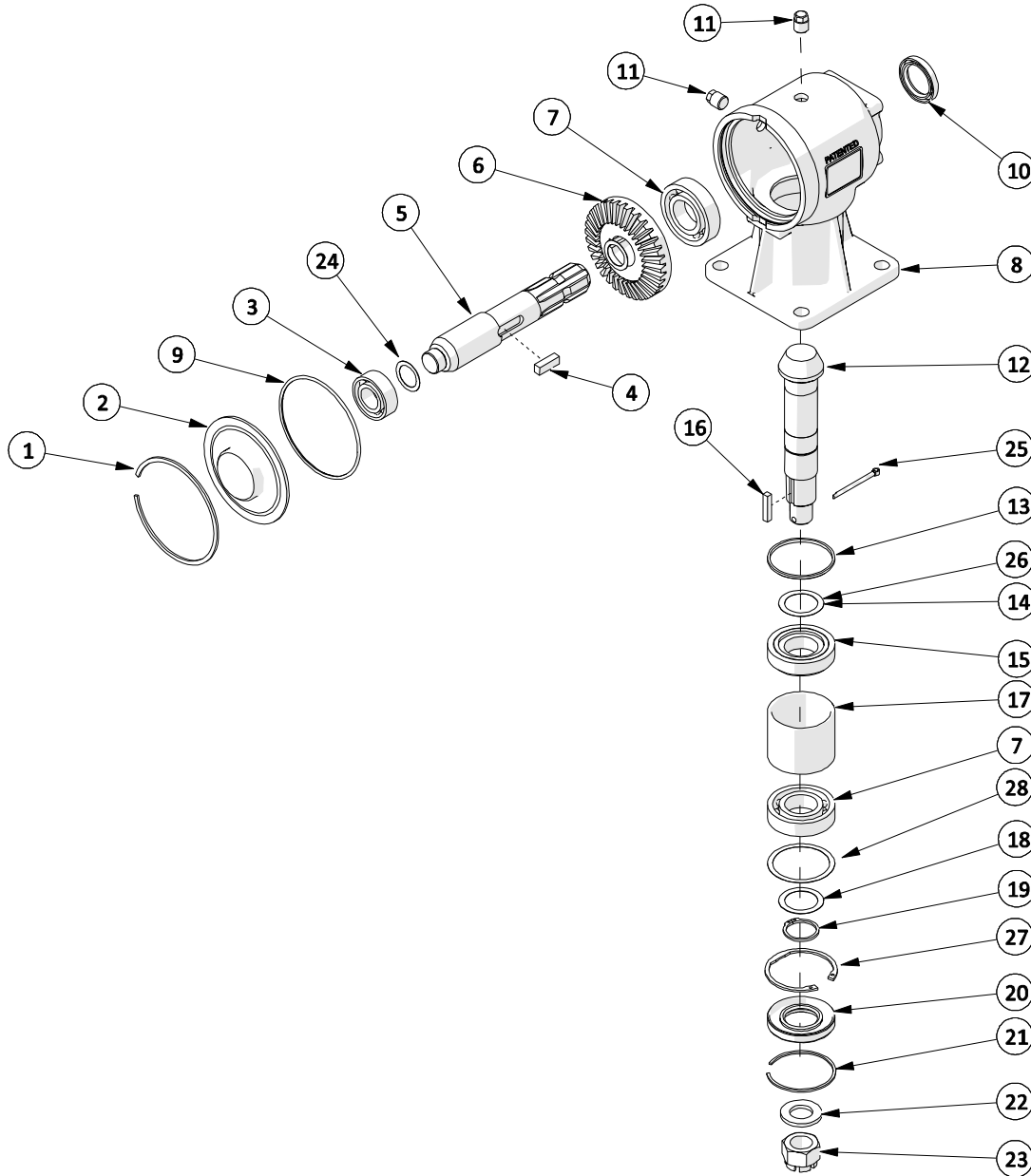

ITEM	PART #	DESCRIPTION	QTY
1	521110	SNAP RING (3 PCS)	1
2	521111	COVER PLATE	1
3	521112	BEARING - 6205	1
4	521113	KEY - 10 X 8 X 30 MM (3 PCS)	1
5	521114	INPUT SHAFT - 1 3/8" X 6 SPLINE	1
6	521115	GEAR	1
7	521116	BEARING - 6207	2
8	521117	CASING	1
9	521118	O-RING	1
10	521120	OIL SEAL - 35 X 52 X 10	1
11	521482	HEX PIPE PLUG	2
12	521121	PINION SHAFT	1
13	521361	TAPERED SPACER RING	1
14	521123	SHIM KIT (3 PCS)	1
15	521362	BEARING - TAPERED ROLLER	1

ITEM	PART #	DESCRIPTION	QTY
16	521390	KEY - 1/4 X 1-5/16 (3 PCS) KIT	1
17	521124	SPACER TUBE	1
18	521366	SHIM KIT (3 PCS)	1
19	521125	SNAP RING (3 PCS)	1
20	521127	OIL SEAL - 35 X 72 X 10	1
21	521128	SNAP RING - SB72	1
22	521129	WASHER - 25 X 44 X 4 (3PC/KIT)	1
23	521130	CASTLE NUT - M24	1
24	521359	SHIM KIT - (2PCS)	1
25	521122	COTTER PIN - 5 X 50 (3 PCS)	1
26	521360	SHIM KIT - (3PCS)	1
27	521126	SNAP RING KIT (3 PCS)	1
28	521491	SHIM KIT (3 PCS)	1
29	521012	GEARBOX - COMPLETE	1

## 4.9 Deck Gearbox – Reverse Rotation

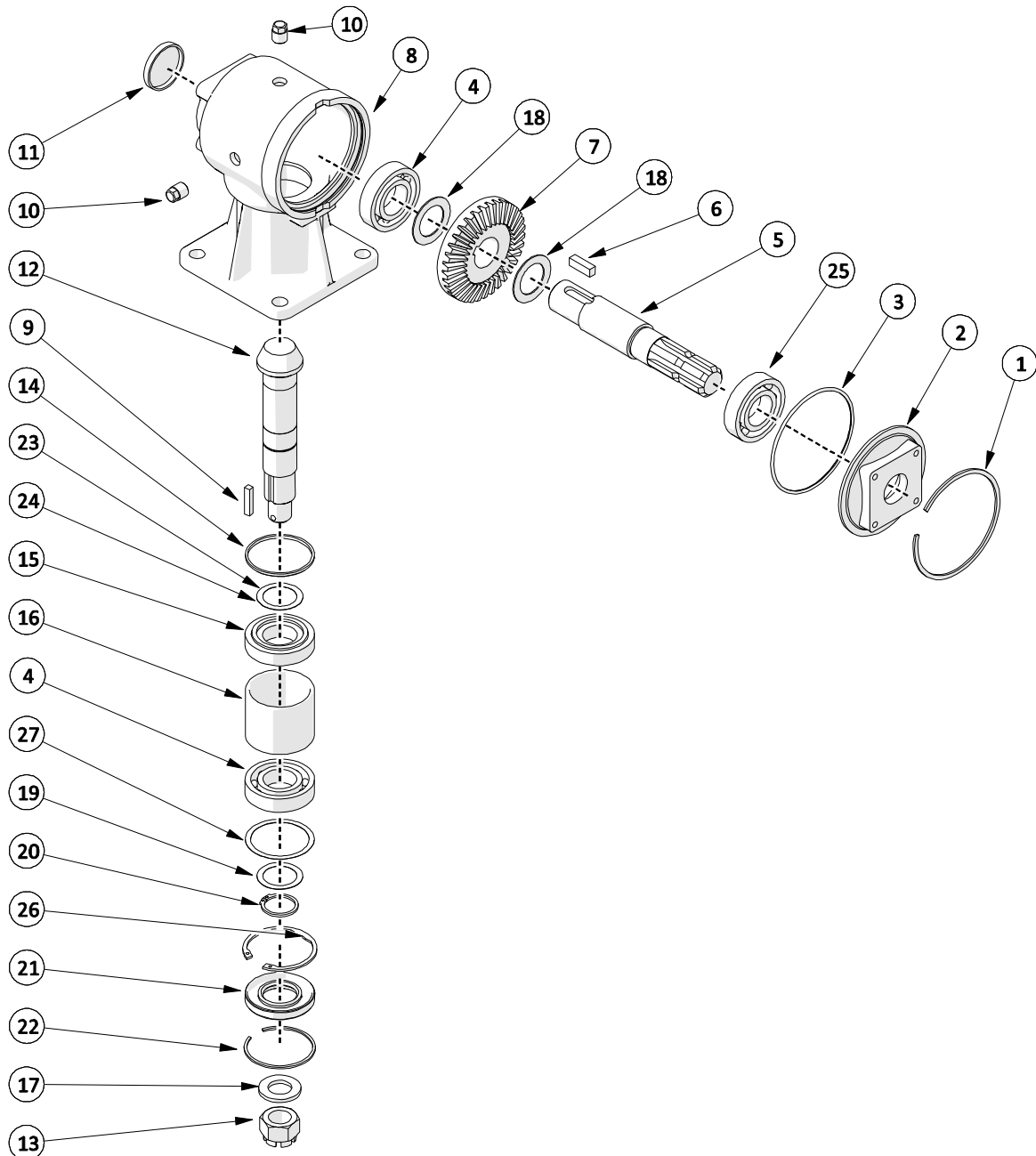

ITEM	PART #	DESCRIPTION	QTY
1	521110	SNAP RING (3 PCS)	1
2	521203	INPUT COVER PLATE	1
3	521118	O-RING	1
4	521116	BEARING - 6207	2
5	521201	INPUT SHAFT - GEARBOX RH	1
6	521113	KEY - 10 X 8 X 30 MM (3 PCS)	1
7	521115	GEAR	1
8	521117	CASING	1
9	521390	KEY - 1/4 X 1 5/16 (3 PCS) KIT	1
10	521482	HEX PIPE PLUG	2
11	521149	CASE PLUG - INPUT SHAFT	1
12	521121	PINION SHAFT	1
13	521130	CASTLE NUT M24	1
14	521361	TAPERED SPACER RING	1
15	521362	BEARING - 7207E	1

ITEM	PART #	DESCRIPTION	QTY
16	521124	SPACER TUBE	1
17	521129	WASHER - (3 PCS)	1
18	521008	SHIM KIT (9PCS)	2
19	521366	SHIM KIT (3 PCS)	1
20	521125	SNAP RING (3 PCS)	1
21	521127	OIL SEAL - 35 X 72 X 10	1
22	521128	SNAP RING (2 PCS)	1
23	521360	SHIM KIT (3 PCS)	1
24	521491	SHIM KIT (3 PCS)	1
25	521153.01	BEARING - 6007	1
26	521126	SNAP RING KIT (3 PCS)	1
27	521491	SHIM KIT (3 PCS)	1
28	521033	COMPLETE GEARBOX	1

# 5 DECALS

## 5.1 Safety

If decals become faded, damaged, or lost, replace immediately. Order decal according to corresponding part number below. Complete decal kits are also available.

**TDR-15 DECAL KIT - 524004**

**TRD-12 DECAL KIT - 524002**

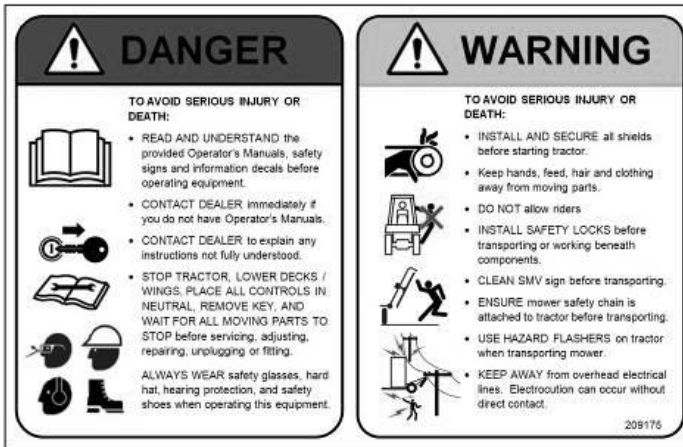

209175

**DECAL – GENERAL SAFETY**



209113

**DECAL – REPLACE SHIELDS**



521820

**DECAL - CAUTION**

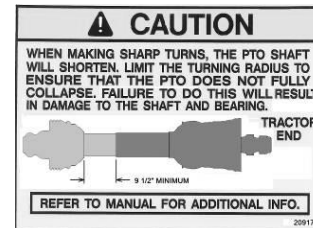

209171

**DECAL – PTO COLLAPSE**



209173

**DECAL - ROTATING BLADE DANGER**



209115

**DECAL – OEM PARTS**



521817

**DECAL – PROGRESSIVE TURF (B Models)**



521817DE

**DECAL – PROGRESSIVE TURF (D Models)**

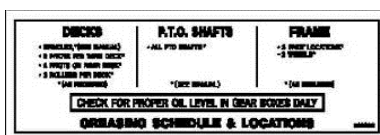

526003

**DECAL – GREASING SCHEDULE**

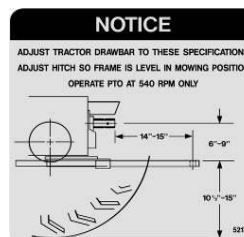

521784

**DECAL - NOTICE**

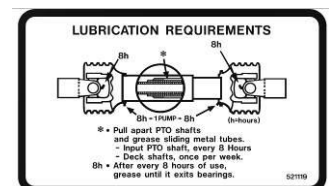

521119

**DECAL – PTO GREASE**

**PROGRESSIVE**  
**TDR-15**  
**ROLLER MOWER**

**PROGRESSIVE**  
**TDR-12**  
**ROLLER MOWER**

209127  
**TDR-15 ROLLER MOWER**  
**DECAL**

209126  
**TDR-12 ROLLER MOWER**  
**DECAL**



521451  
**DECAL DANGER –**  
**INNER SHAFT**



521455  
**DECAL – DANGER – OUTER TUBE**



210237  
**SAFETY SIGN – OUTER**  
**GUARD**



210238  
**DECAL – CE**  
**WARNING**



210239  
**DECAL – INNER SHAFT**



**GREASE POINT DECAL**  
**(521014)**

## 5.2 General Info