

OPERATOR'S MANUAL & PARTS LIST



Universal Aera-vator MODEL UA60T

FIRST PRODUCTS INC.

164 Oakridge Church Road
Tifton, Georgia 31794 U.S.A.

Phone (229) 382-4768

1-800-363-8780

Fax (229) 382-0506

Web: www.1stproducts.com Email: Sales@1stproducts.com

Manual Part #: UA50-109

Model - Serial Number
UA60T - 1001 thru ____
Printed in U.S.A.
PB 0314

Table of Contents

Operator's Manual

Introduction..... 2

Safety 3

 Safety Alert Symbol..... 3

 Safe Operating Practices 3

Specifications 10

 Dimensions 11

 Torque Requirements..... 11

Product Overview 12

Operation 13

 Pre-Start 13

 Operating Instructions..... 13

Maintenance..... 16

 Recommended Maintenance Schedule(s)..... 16

 Periodic Maintenance 17

 Check Engine Oil Level..... 17

 Check Air Cleaner..... 17

 Check Battery Charge 17

 Check Hydraulic Oil Level 18

 Check Tire Pressure 18

 Check for Loose Hardware 18

 Checking Rotor Shaft Tines..... 18

 Check Condition of Belts..... 19

 Lubricate Grease Fittings 19

 Check Spark Plugs 19

 Check Fuel Filter..... 19

 Change Hydraulic System Filter 19

 Clean Engine 20

 Waste Disposal..... 20

 Motor Oil Disposal 20

 Battery Disposal..... 20

 Rotor Shaft Service..... 21

 Rotor Shaft Disassembly..... 21

 Rotor Hub Disassembly 21

 Rotor Hub Re-Assembly..... 21

 Rotor Shaft Re-Assembly 21

WARRANTY INFORMATION 23

Parts Book

Power Transmission Accessories Group 24

Power Transmission Group 25

Fuel Tank and Electrical Group..... 27

Hydraulics Group..... 29

Lift Axle Group 31

Covers & Decals Group..... 32

Roller Attachment..... 33

Brush Attachment (Optional)..... 34

Aera-vator Shaft..... 35

Multi-tine Shaft..... 36

Aera-slicer Shaft 37

Multi-Spike Shaft..... 38

Coring Shaft..... 39

Lighting Group 40

Troubleshooting 41

Schematics 43

 Machine Electrical 43

 Control Electrical 44

 Lighting..... 45

 Hydraulics 46

Introduction

Thank you for purchasing the First Products Aera-vator. This machine is designed to withstand years of continuous use and is manufactured by skilled workers using quality materials. Proper assembly, maintenance, and safe operating practices will provide years of satisfactory service.

Using This Manual

This operator's manual is designed to help familiarize you with safety, assembly, operation, adjustments, troubleshooting, and maintenance. Read this manual and follow the recommendations to help ensure safe and efficient operation. Read the warranty located on page 23. Fill in the required information on the warranty registration card provided, and return it to the address on the front of this manual. The warranty registration must be returned to validate warranty.

To order a new Operator's and Parts Manual (Part number UA50-109), contact your authorized dealer or write to the address listed below in the *Owner Assistance* paragraph. Include the model and serial numbers of your unit. In addition to this, you may also download a copy of the Operator's Manual from our web site: www.1stproducts.com

The information contained within this manual was current at the time of printing. Some parts may change slightly to assure you of the best performance.

Terminology:

"Right" or "Left" as used in this manual is determined by standing behind the machine and facing the direction of operation.

Definitions:

NOTE: A special point of information related to its preceding topic. The author's intention is that you read and note this information before continuing.

IMPORTANT: A special point of information that the author feels you must be aware of before continuing with the instructions that follow.

Owner Assistance

If customer service or repair parts are required, contact your First Products dealer. A dealer has trained personnel, repair parts, and the equipment needed to service your machine. These parts have been specifically designed for your Aera-vator and should only be replaced by genuine First Products parts.

Serial Number Plate

Refer to Figure 1 for the location of your serial number plate.

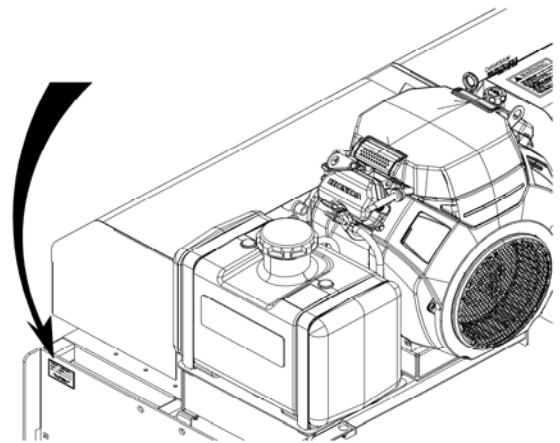

Figure 1. Serial number Plate

For prompt service, always use the serial number and model number when ordering parts from your First Products dealer. Fill in Model and serial numbers of each unit you've purchased in the section below. If for any reason you do not understand any part of this manual or not satisfied with service you received, discuss the matter with your dealership service manager. For further assistance, write to:

First Products, Inc
Attn: Product Support
164 Oakridge Church Road
Tifton, Ga 31794

Date Purchased _____

UA60T Serial No. _____

Engine Model No. and Spec. No. _____

Engine Serial No. _____

Safety

Safety

Safety Alert Symbol



This is the safety alert symbol. It means:
ATTENTION! BECOME ALERT! YOUR SAFETY IS INVOLVED!

⚠ DANGER: White lettering / Red background
 Indicates an imminently hazardous situation, which, if not avoided, will result in death or serious injury. This signal word is limited to the most extreme situations, typically for machine components that, for functional purposes, cannot be guarded.

⚠ WARNING: Black lettering / Orange background
 Indicates a potentially hazardous situation, which, if not avoided, could result in death or serious injury, and includes hazards that are exposed when guards are removed. It may also be used to alert against unsafe practices.

⚠ CAUTION: Black lettering / Yellow background
 Indicates potentially hazardous situation, which, if not avoided, could result in minor or moderate injury. It may also be used to alert against unsafe practices.

Safe Operating Practices

Training

- Read Operator's manual and other training material. If the operator(s) or mechanic(s) can not read English it is the owner's responsibility to explain this material to them.
- Become familiar with the safe operation of the equipment, operator controls and safety signs.
- All operators and mechanics should be trained.
- Never let children or untrained people operate or service the equipment. Local regulations may restrict the age of the operator.

Preparation

- Evaluate the terrain to determine if any thing is needed to properly and safely perform the job.
- Wear appropriate clothing including safety glasses, substantial footwear, long trousers, and hearing protection. Do not operate with long hair, loose clothing or jewelry; these could get tangled in moving parts.

⚠ CAUTION
<p>This machine produces sound levels in excess of 85 dBA at the operator's ear and can cause hearing loss through extended periods of exposure.</p> <p>Wear hearing protection when operating this machine.</p>

- Inspect the area where equipment is to be used and remove all rocks, toys, sticks, wires, and other foreign objects which can be thrown by the machine and may cause personal injury to the operator or bystanders.

Safety**⚠ DANGER**

In certain conditions gasoline is extremely flammable and vapors are explosive.

A fire or explosion from gasoline can burn you, others, and cause property damage.

- Fill the fuel tank outdoors in an open area, when the engine is cold. Wipe up any gasoline that spills.
- Never refill the fuel tank or drain the machine indoors or inside an enclosed trailer.
- Do Not fill the fuel tank completely full. Add gasoline to the fuel tank until the level is 1/4 to 1/2 inch (6–13 mm) below the bottom of the filler neck. This empty space in the tank allows gasoline to expand.
- Never smoke when handling gasoline, and stay away from an open flame or where gasoline fumes may be ignited by spark.
- Store gasoline in an approved container and keep it out of the reach of children.
- Add fuel before starting the engine. Never remove the cap of the fuel tank or add fuel when engine is running or when the engine is hot.
- If fuel is spilled, Do Not attempt to start the engine. Move away from the area of the spill and avoid creating any source of ignition until fuel vapors have dissipated.
- Do Not operate without entire exhaust system in place and in proper working condition.

⚠ DANGER

In certain conditions during fueling, static electricity can be released causing a spark which can ignite gasoline vapors. A fire or explosion from gasoline can burn you and others and cause property damage.

- Always place gasoline containers on the ground away from your vehicle before filling.
- Do Not fill gasoline containers inside a vehicle or on a truck or trailer bed because interior carpets or plastic truck bed liners may insulate the container and slow the loss of any static charge.
- When practical, remove gas-powered equipment from the truck or trailer and refuel the equipment with its wheels on the ground.
- If this is not possible, then refuel such equipment on a truck or trailer from a portable container, rather than from a gasoline dispenser nozzle.
- If a gasoline dispenser nozzle must be used, keep the nozzle in contact with the rim of the fuel tank or container opening at all times until fueling is complete.

⚠ WARNING

Gasoline is harmful or fatal if swallowed. Long-term exposure to vapors has caused cancer in laboratory animals. Failure to use caution may cause serious injury or illness.

- Avoid prolonged breathing of vapors.
- Keep face away from nozzle and gas tank/container opening.
- Keep away from eyes and skin.
- Never siphon by mouth.

Safety

Operation

⚠ WARNING

Operating engine parts, especially the muffler, become extremely hot. Severe burns can occur on contact and debris, such as leaves, grass, brush, etc. can catch fire.

- Allow engine parts, especially the muffler, to cool before touching.
- Remove accumulated debris from muffler and engine area.
- Install and maintain in working order a spark arrester before using equipment on forest-covered, grass-covered, or brush-covered unimproved land.

⚠ WARNING

Engine exhaust contains carbon monoxide, which is an odorless deadly poison that can kill you.

Do Not run engine indoors or in a small confined area where dangerous carbon monoxide fumes can collect.

- Stop engine, and wait for all moving parts to stop:
 - Before refueling.
 - Before checking oil levels
- **NEVER** carry passengers. Do not operate the machine when people, children, or pets are in the area.
- Be alert, slow down and use caution when making turns. Look behind and to the side before changing directions.
- Do not operate the machine under the influence of alcohol and drugs.
- Use extreme care when loading or unloading the machine from a trailer or truck.
- Use extreme caution when approaching blind spots, corners, shrubs, trees, or other object that may obscure vision.
- Operate only in daylight or good artificial light, keeping away from hidden hazards.
- Never operate the machine with damaged guards, shields, or covers. Always have safety shields, guards, switches and other devices in place and in proper working condition.
- **DO NOT** change the engine governor setting or over speed the engine.
- Stop engine, wait for all moving parts to stop, and remove key:
 - Before checking, cleaning or working on the machine.
 - After striking a foreign object or abnormal vibration occurs (inspect the machine for damage and make repairs before restarting and operating).

Safety

Slope Operation

Use **Extreme** caution when operating and/or turning on slopes as loss of traction and/or tip-over could occur. The operator is responsible for safe operation on slopes.

DANGER

Operating on wet grass or steep slopes can cause sliding and loss of control. Wheels dropping over edges, ditches, steep banks, or water can cause rollovers, which may result in serious injury, death, or drowning.

- **Do Not operate on slopes when grass is wet.**
 - **Do Not operate on slopes greater than 15 degrees.**
 - **Do Not operate near drop-offs or near water.**
 - **Reduce speed and use extreme caution on slopes.**
 - **Avoid sudden turns or rapid speed changes.**
- See the inside of the back cover to determine the approximate slope angle of the area to be operated on.
 - Remove or mark obstacles such as rocks, tree limbs, etc. from the area. Tall grass can hide obstacles.
 - Watch for ditches, holes, rocks, dips, and rises that change the operating angle, as rough terrain could overturn the machine.
 - Always avoid sudden starting or stopping on a slope. If tires lose traction, turn off aerator and proceed slowly off the slope.

Safety

Maintenance and Storage

- Lift aerator out of ground, stop engine, and remove key before adjusting, cleaning, or repairing.
- Keep power transmission components (belts, pump, engine, etc.) free of debris. The debris can become combustible which may result in a fire.
- Let engine cool before storing and do not store near flame or any enclosed area where open pilot lights or heat appliances are present.
- Drain fuel from tank while storing.
- Pin the cylinder lock-out bar into place and carefully release pressure from components with stored energy.
- Never allow untrained personnel to service machine.
- Disconnect the negative terminal cable from the battery before making any repairs. If battery is required to be removed, always disconnect the negative cable first and always connect the positive first while reinstalling.
- Charge battery in an open, well-ventilated area, away from sparks and flames.
- Keep all guards, shields, and all safety devices in place and in safe working condition.
- Check bolts frequently to maintain proper tightness.
- Check belts frequently for proper tensioning and wear condition.
- Check all moving components for worn or deteriorating components that could create a hazard.
- All replacement parts must be the same as or equivalent to the parts supplied as original equipment.

- Check fluid levels daily during operation. If fluids are needed, fill with the correct fluids specified.
- Inspect all hydraulic hoses and adapters daily for leaks or defects.
- When brushes are attached, Anti-tip leg must be extended before disconnecting hitch from tow vehicle.

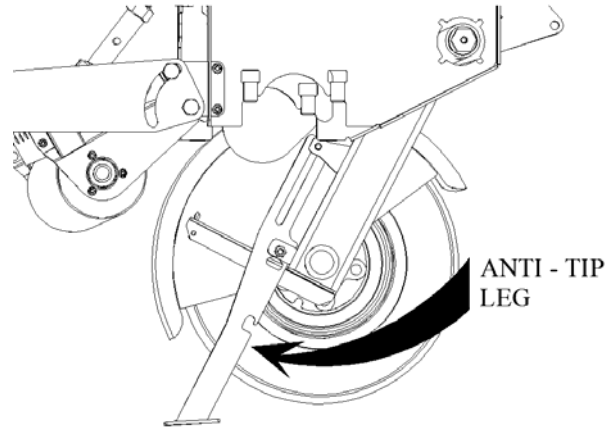

Anti-tip Leg

⚠ WARNING

Hydraulic fluid escaping under pressure can penetrate skin and cause injury. Fluid accidentally injected into the skin must be surgically removed within a few hours by a doctor familiar with this form of injury or gangrene may result.

- Make sure all hydraulic fluid hoses and lines are in good condition and all hydraulic connections and fittings are tight before applying pressure to hydraulic system.
- Keep body and hands away from pinhole leaks or nozzles that eject high pressure hydraulic fluid.
- Use cardboard or paper, not your hands, to find hydraulic leaks.
- Safely relieve all pressure in the hydraulic system by placing the motion control levers in neutral and shutting off the engine before performing any work on the hydraulic system.

Safety

Safety and Instructional Decals

- Keep all safety signs legible. Remove all grease, dirt and debris from safety signs and instructional labels.
- Replace all worn, damaged, or missing safety signs.
- When replacement components are installed, be sure that current safety signs are affixed to the replaced components.
- If an attachment or accessory has been installed, make sure current safety signs are visible.

New safety signs may be obtained from your authorized First Products, Inc. equipment dealer or distributor.

- Safety sign may be affixed by peeling off the backing to expose the adhesive surface. Apply only to a clean, dry surface. Smooth to remove any air bubbles.
- Familiarize yourself with the following safety signs and instruction labels. They are critical to the safe operation of your First Products machine.

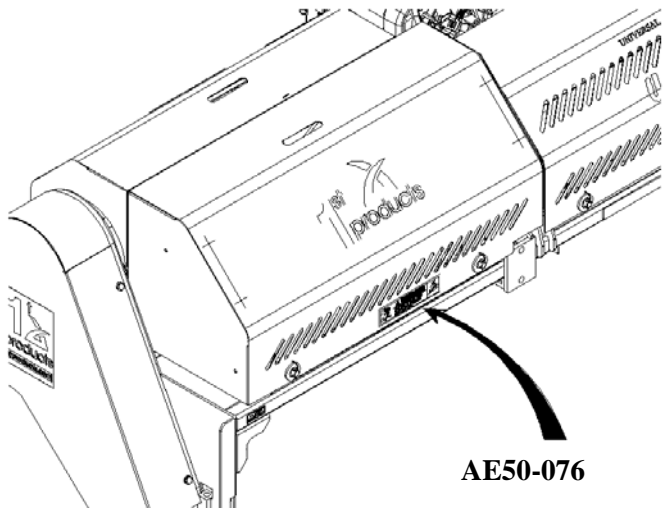

REAR COVER

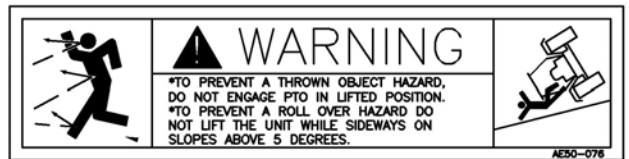

AE50-076
THROWN OBJECT HAZARD

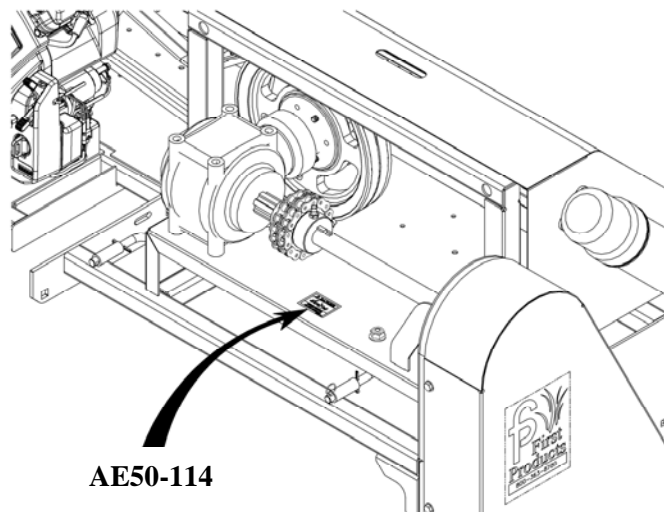

UNDER EXPOSED JACK SHAFT



AE50-114
DANGER HAZARD

Safety

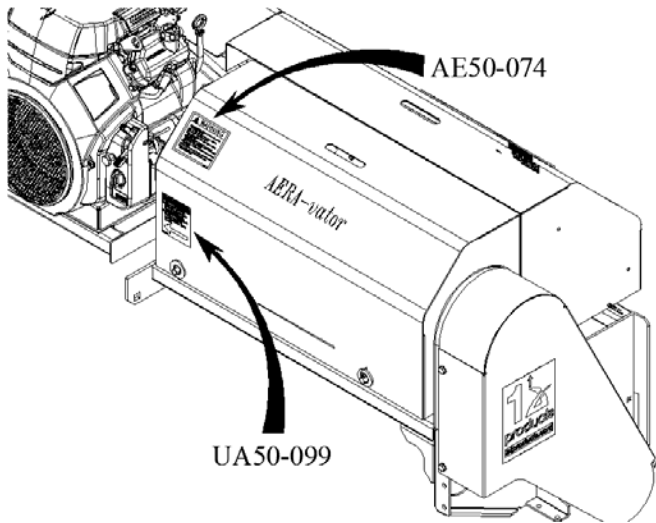

FRONT COVER



AE50-074
GENERAL WARNING DECAL

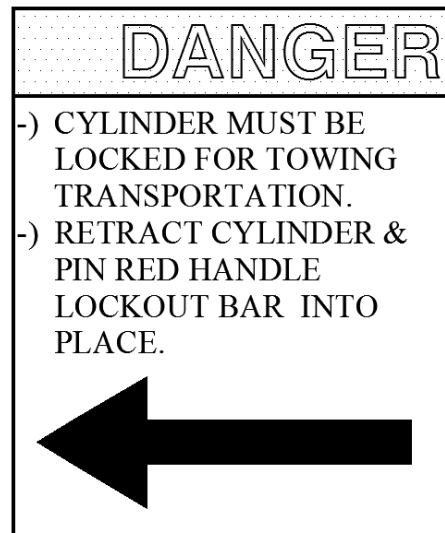

UA50-099
CYLINDER LOCK DECAL

Specifications

Specifications

Engine

- Engine Specifications: See your Engine Owner's Manual
- RPM: Full Speed 3400 +/- 100 RPM (No Load)
Idle: 1600 RPM

Fuel System

- Capacity: 5 gal. (18.9 L)
- Type of Fuel: Regular unleaded gasoline, 87 octane or higher
- Fuel filter: In-line 40 Micron
Honda P/N :16910-Z6L-003

Electrical System

- Charging System: Flywheel Alternator
- Charging Capacity: 20 amps
- Battery Type, BCI Group U1
- Battery Voltage: 12 Volt
- Polarity: Negative Ground
- Fuses: One 20 amp blade type

Safety System

- Transport lock must be used when machine is hauled from one venue to another

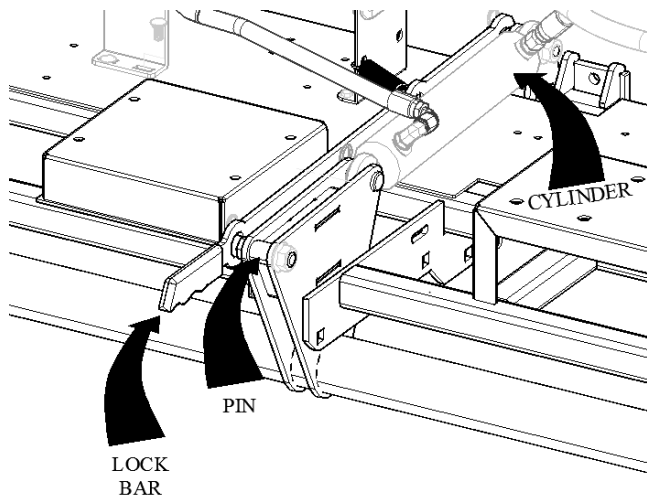

Figure 2. Transport Lock

Operator Controls

- The operator controls the lifting, lowering, and aeration from a hand-held control box with three switches (Figure 3).

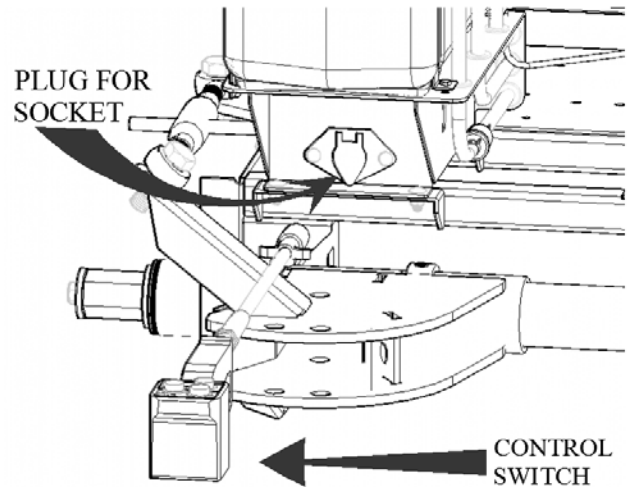

Figure 3. Hand-held Control

- The operator accesses the engine controls via its control panel found opposite its oil filter side.

o Engine Throttle Control

The throttle is used to control engine speed. Moving the throttle lever upward will increase engine speed and moving downward will decrease engine speed.

o Choke Control

The choke is used to aid in starting a cold engine. Pulling the choke outward will put the choke in the "ON" position and pushing the knob inward, will put the choke in the "OFF" position. Do Not run a warm engine with choke in the "ON" position.

o Ignition Switch

The ignition switch is used to start and stop the engine. The switch has three positions "OFF", "RUN" and "START". Insert key into switch and rotate clockwise to the "RUN" position. Rotate clockwise to the next position to engage the starter (key must be held against spring pressure in this

Specifications

position). The PTO switch must be in the off position to start the engine.

- Auto Throttle Handle

With the Auto throttle handle in the down position (locked position) the engine's RPM will increase as the machine is lowered into the ground. As the unit is lifted the engine will return to idle.

The auto throttle can be disengaged when auto throttling is not required by raising the auto throttle handle into the unlocked position.

- Hour Meter

The hour meter is connected to the ignition switch to record the amount of run time on the unit. The hour meter will work while the engine is operating.

Transport Options

- The UA-60T can be transported by using its standard 2" ball coupler or its draw bar option.

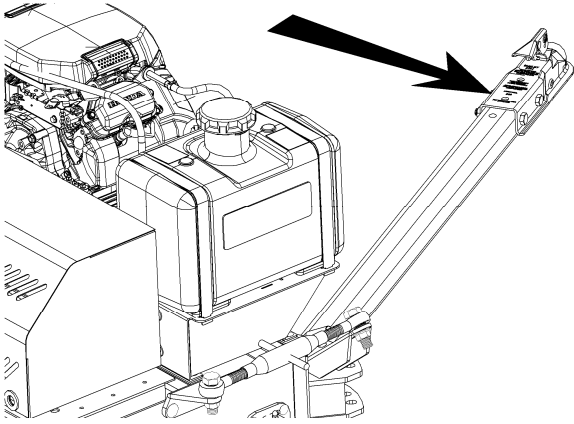

Figure 4. Standard 2" Ball Coupler

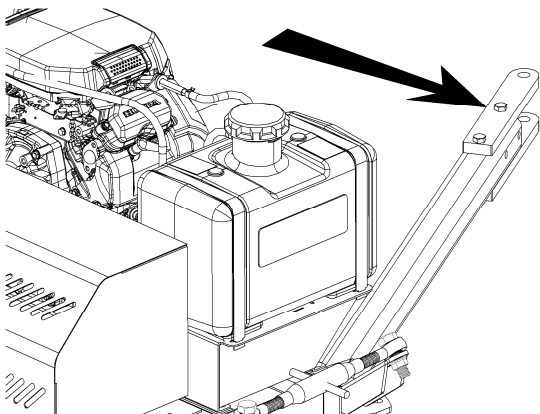

Figure 5. Draw Bar Option

Hydraulic Lift System

- Hydraulic Pump: ½ Gal/Min Fixed Displacement Gear Pump
- Hydraulic Cylinder: 2" Bore with 8" Stroke
- Hydraulic Oil Type: **A68 Hydraulic Oil.**
- Hydraulic Oil Capacity: 1.7 gal. (6.4 L)

Tires & Wheels

- Tires are 20 ½" on 8" wheels fastened with five lug nuts on 5 ½" centers.
- Tires have highway tread and are 16 ply with a load rating F.

Dimensions

Overall Width:	95 ½" (Outside of Tires)
Overall Height:	48 ½" (Raised & Level)
Overall Depth:	36" (Tongue Removed) 80" (Back of Fender to Tongue)

Torque Requirements

Engine Mounting bolts	38-40 ft-lbs (51 – 56 N-m)
Wheel Lug nuts	90-95 ft-lbs (122-129 N-m)
Tines in Rotor Aera-vator Shaft	210-215 ft-lbs (284- 291 N-m)
Implement frame to Tractor mount bolts	111 – 115 ft-lbs (150 -156 N-m)
1/4 UNC Standard Bolts	11 ft-lbs (14 N-m)
5/16 UNC Standard Bolts	21 ft-lbs (28 N-m)
3/8 UNC Standard Bolts	38 ft-lbs (51 N-m)
1/2 UNC Standard Bolts	85 ft-lbs (120 N-m)
5/8 UNC Standard Bolts	175 ft-lbs (235 N-m)

Operation

Product Overview

Before operating the UA-60T, it is necessary to understand how the machine works and why it functions in such manner.

The machine uses an engine to power two power transmission components: Hydraulic pump & Electric clutch. The hydraulic pump is used to lift and lower the machine. The electric clutch engages the rotor shaft and causes the tines to vibrate.

Hydraulic Circuit

When the engine is on, the pump is continuously circulating hydraulic oil from the reservoir, to the pump, to the valve block, and back to the reservoir. When the operator presses the momentary switch for the raise or lower function on the hand-held controller (Figure 3) the fluid entering the valve block is diverted to the cylinder causing the machine to raise or lower. See Figures 6 and 7.

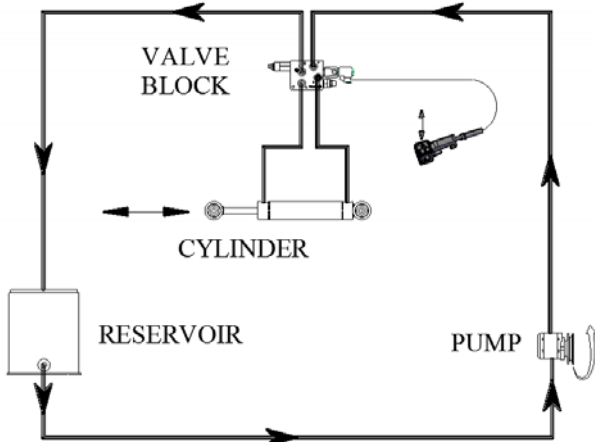

Figure 6. Hydraulic Circuit

Automatic Throttle Activation

The engine throttle is tied to a cable-spring assembly which is pulled when the lift cylinder is extended, Figure 8. When the machine is lowered, the cylinder extends; this action pivots the bracket hooked to the spring and cable assembly. As the cable is pulled, the engine speed is increased. Likewise, when the machine is lifted, the cable is retracted by a spring on the engine.

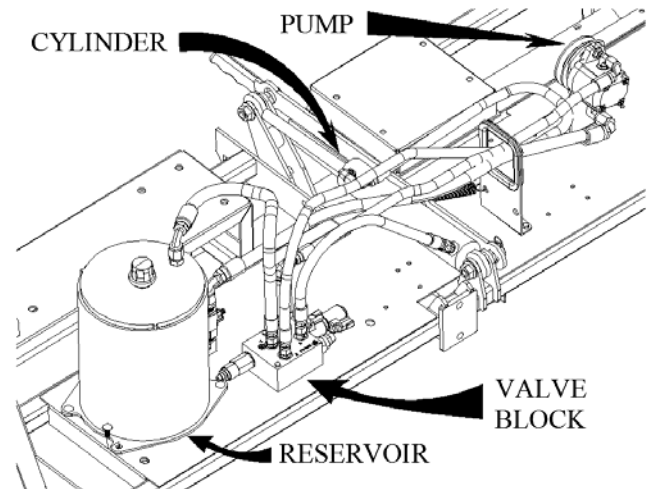

Figure 7. Hydraulics

Aeration Mechanism

The UA-60T is designed to start aeration when the electric clutch is turned on. With the Auto Throttle Handle, Figure 8, position down, the engine will automatically throttle up as it lowers to the ground. Once the tines start to touch the ground, the electric clutch may be engaged to start the patented vibrating tines. To lower the machine without throttling up the engine, simply lift the pivot catch handle, Figure 8, and allow the stud to travel in the slot while the machine lowers to the ground.

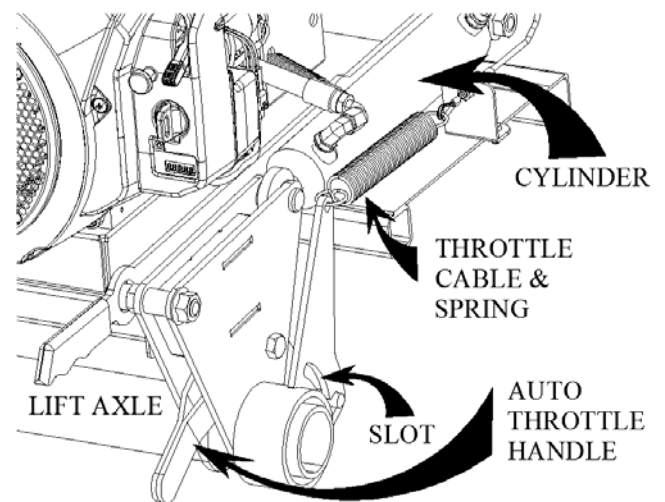

Figure 8. Automatic Throttle Mechanism

Operation

Operation

Note: The left and right sides of the machine are defined as standing behind it and facing the direction of operation.

Pre-Start

Fill fuel tank, for best results use clean, fresh regular unleaded gasoline with an octane rating of 87 or higher.

Do Not add oil to gasoline.

Do Not overfill fuel tank. Never fill fuel tank so that the fuel level rises above a level that is ½ inch (13 mm) below the bottom of the filler to allow for fuel expansion and prevent fuel spillage.

Make sure the operator understands the controls, their locations, their functions, and their safety requirements.

Refer to the Maintenance section and perform all necessary inspection and maintenance steps.

Operating Instructions

Hitching Machine and Set-up

The UA-60T can be hitched to any working vehicle desired for operation. The standard 2 inch ball coupler is utilized for most applications. The optional draw-bar attachment can be used in situations where the 2" ball coupler is not feasible, such as small utility tractors.

Once the machine is connected, the hand-held control switch must be installed. Located under the fuel tank, a socket receives the plug from the control switch. Uncoil the switch and use ties as necessary to ensure the cord does not make contact with the vehicle in turns or the ground upon lowering to the ground.

Leveling Aera-vator for Operation

The UA-60T is equipped with a top link connected to the sway bar on the right side. This top link is adjusted in or out to level the aerator during operation.

1. With the machine hitched at the worksite, start the engine.

2. Lift the Auto Throttle Handle to disengage the throttle, Figure 8, and use the control box to lower the machine to the ground.
3. Rotate the top link as necessary to level the machine, Figure 9.
4. Raise the machine and engage the Auto Throttle Handle for use.

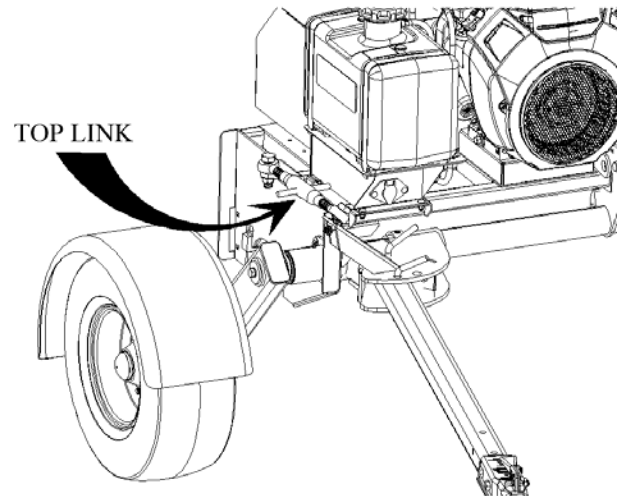

Figure 9. Leveling Aera-vator

Start the Engine

1. Before starting the engine, if the machine is in the lowered position. **The Auto Throttle Handle, Figure 8, must be lifted to disengage the throttle.**
2. On a cold engine, pull the choke knob outward into the "ON" position.
3. On a warm engine, leave the choke in the "OFF" position.
4. Turn ignition switch to the "START" position. Release the switch as soon as the engine starts.

IMPORTANT: Do NOT crank the engine continuously for more than ten seconds at a time. If the engine does not start, allow 60 second cool-down period between starting attempts. Failure to follow these guidelines can burn out the starter motor.

5. If the engine is difficult to start, the throttle can be used **momentarily**. As soon as the engine starts, cut the throttle down to the idle position.
6. If the choke is in the "ON" position, gradually return choke to the "OFF" position as the engine warms up.

Operation

Aeration

With the engine running and the machine fully lifted:

1. Ensure the Auto Throttle Handle is lowered back into position to allow the throttle cable to be pulled when machine is lowered to ground.

⚠ DANGER

The movement of the rotors on the machine is dangerous. Contact with rotor shaft can cause serious injury or death. Do NOT put hands or feet in the working area of the rotor shaft while activated.

2. Tow machine to starting point on worksite and lower using hand-held control switch, Figure 3.
3. Adjust the ground speed accordingly. Slow down to allow tines to penetrate deeper. The chain hanging on the left side of the machine is a visual indicator for depth. If the chain is touching the turf, full depth is achieved.
4. Press the control switch to lift the machine when desired.

Operating the Attachments

The UA-60T is equipped to have both a solid roller and a brush fastened to the frame. Attachments can be seen in further detail in the parts list portion of this manual.

The roller is seen in Figure 10. It is made to primarily float using a slot located on the top bracket on the frame. When down pressure from the roller is desired, the top link is adjusted to lower the roller downward until down pressure is achieved and the pin is at the top of the slot.

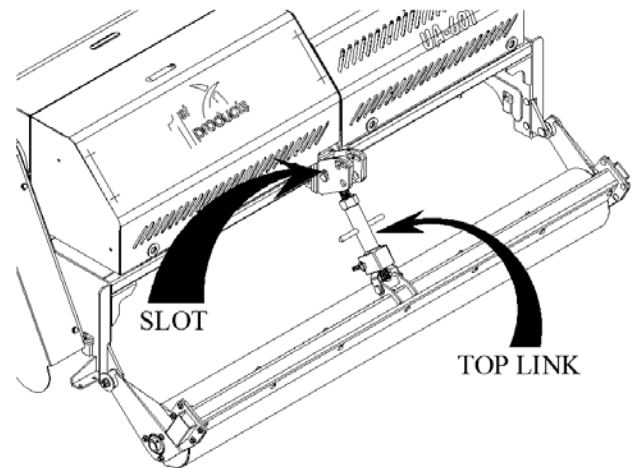

Figure 10. Roller Attachment

The brush is shown in Figure 11. It is fastened to the frame in a three-point hitch configuration to allow smooth floatation. The brush easily locks into place for transportation by simply lifting the brush to the top of its range. The brush can be modified to various widths and configurations to conform to the user's needs.

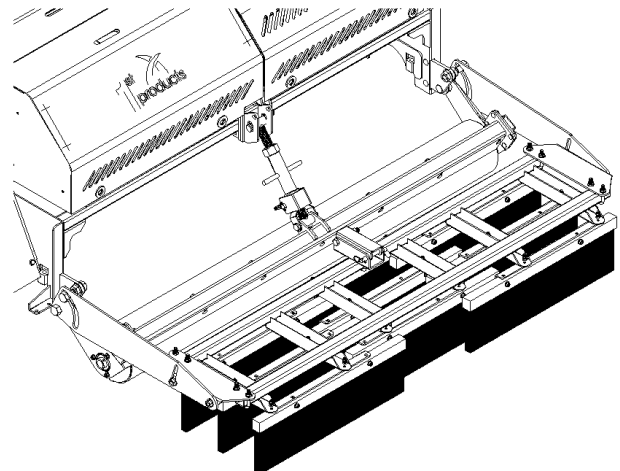

Figure 11. Brush Attachment

Operation

Offsetting unit

The unit may be operated either directly behind the tow vehicle or offset to the side of the vehicle. The unit can be offset by changing the tongue position, Figure 12. The offset can be adjusted between the two outer positions shown by aligning the holes in the tongue with either of the sets of holes in the Tongue Swivel.

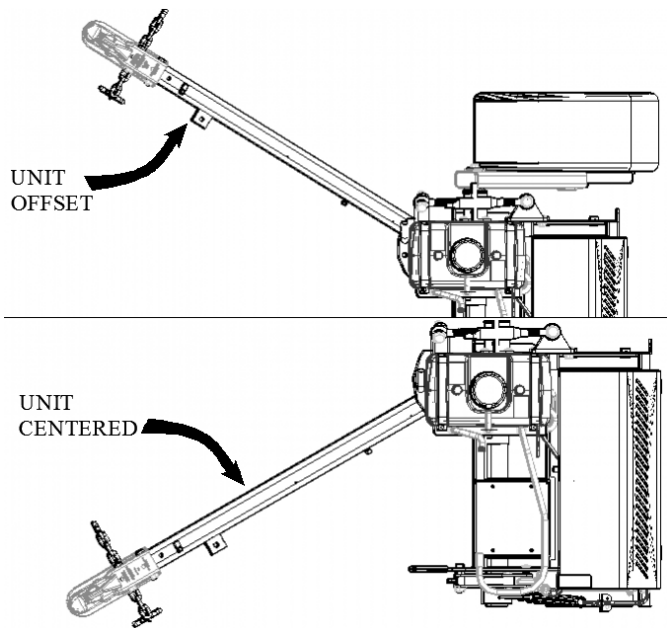

Figure 12. Offsetting Unit

Transporting unit

Before transporting the UA-60T from one location to another, the red handled Cylinder Lock-Bar located by the lift cylinder must be pinned to the cylinder to prevent the machine from gradually leaking down over time. The red handled Cylinder lock-bar is seen in Figure 13.

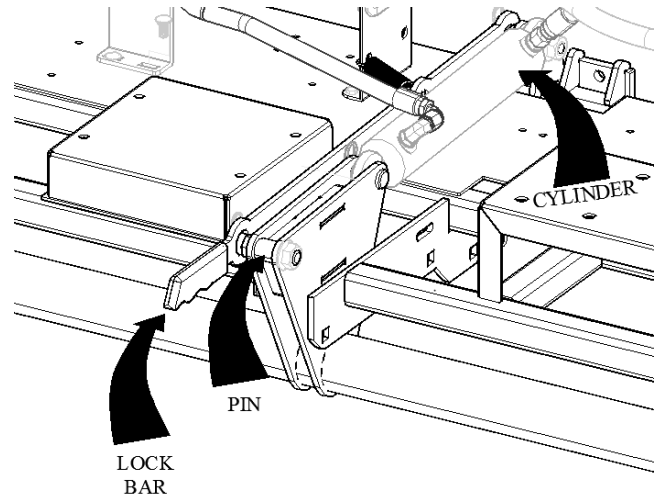

Figure 13. Cylinder Lock Bar

The tongue of the unit should also be locked to its centered position, Figure 12, with the stop bolt being tightened against the tongue and locked into place with the jam nut, Figure 14. **The unit should only be transported while centered behind the tow vehicle with the stop bolt tightened.**

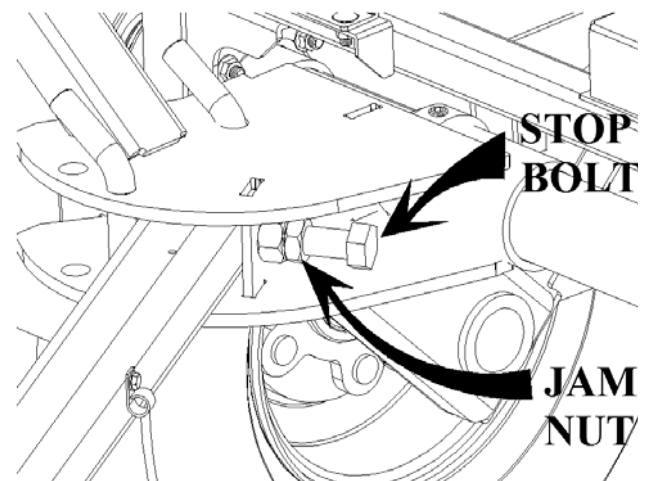

Figure 14. Stop Bolt Location

Maintenance

Maintenance

⚠ WARNING

The engine can become very hot. Touching a hot engine can cause severe burns.

Allow the engine to cool completely before service or making repairs around the engine area.

⚠ WARNING

While maintenance or adjustments are being made, someone could start the engine. Accidental starting of the engine could seriously injure you or other bystanders.

Remove the key from the ignition switch, engage parking brake, and pull the wire(s) off the spark plug(s) before you do any maintenance. Also push the wire(s) aside so it does not accidentally contact the spark plug(s).

Recommended Maintenance Schedule(s)

Maintenance Service Interval	Maintenance Procedure
After the first 5 hours	<ul style="list-style-type: none"> Change the engine oil.
After the first 100 hours	<ul style="list-style-type: none"> Check the Wheel Lug nuts.
After the first 250 hours	<ul style="list-style-type: none"> Change the hydraulic filter.
Before Each use or daily	<ul style="list-style-type: none"> Check the engine oil level. Check for loose hardware Check for loose tines. Clean debris off Engine exhaust and rotor shaft
Every 40 hours	<ul style="list-style-type: none"> Check Hydraulic Oil Level. Check Tire pressures. Check the condition of the belts.
Every 50 hours	<ul style="list-style-type: none"> Service the air cleaner. (May need more often under severe conditions. See Engine Owner's Manual for additional information) Change the Engine oil and Oil filter. Grease Lift Axle at Bushings (3 places).
Every 100 hours	<ul style="list-style-type: none"> Check belts for wear & tear. Clean around belts and pulleys as necessary.
Monthly	<ul style="list-style-type: none"> Check the battery charge.
Yearly	<ul style="list-style-type: none"> Check the wheel lug nuts.

Maintenance

Periodic Maintenance

Check Engine Oil Level

Service Interval: Before each use or daily

1. Engine must be level for checking oil. After starting the engine, disengage the throttle from the pivoting axle by lifting the Auto Throttle Handle (Figure 8) while lowering the machine to the ground.
2. Turn engine off.
3. Check with cool engine.
4. Clean area around dipstick. Remove dipstick and wipe oil off. Reinsert the dipstick. Remove the dipstick and read the oil level.
5. If the oil level is low, fill to the "FULL" mark on the dipstick, Use oil as specified in the Engine Owner's Manual. **Do Not** over-fill.

Important: Do Not operate the engine with the oil level below the "LOW" (or "ADD") mark on the dipstick, or over the "FULL" mark.

Check Air Cleaner

Service Interval: Every 50 hours-Service the air cleaner. (may need more often under severe conditions. See the Engine Owner's Manual for additional information.)

1. Stop engine, wait for all moving parts to stop, and remove key.
2. See Engine Owner's Manual for cleaning instructions.

Check Battery Charge

Service Interval: Monthly

⚠WARNING

CALIFORNIA Proposition 65 Warning

Battery posts, terminals, and related accessories contain lead and lead compounds, chemicals known to the State of California to cause cancer and reproductive harm. Wash hands after handling.

Allowing batteries to stand for an extended period of time without recharging them will result in reduced performance and service life. To preserve optimum battery performance and life, recharge batteries in storage when the open circuit voltage drops to 12.4 volts.

NOTE: To prevent damage due to freezing, battery should be fully charged before putting away for winter storage.

Check the voltage of the battery with a digital voltmeter. Locate the voltage reading of the battery in the table and charge the battery for the recommended time interval to bring the charge up to a full charge of 12.6 volts or greater.

Important: Make sure the negative battery cables are disconnected and the battery charger used for charging the battery has an output of 16 volts and 7 amps or less to avoid damaging the battery (see chart for recommended charger settings).

Voltage Reading	Percent Charge	Maximum Charger Setting	Charging Level
12.6 or greater	100%	16 volts/7 amps	No Charging Required
12.4 - 12.6	75-100%	16 volts/7 amps	30 Minutes
12.2 - 12.4	50-75%	16 volts/7 amps	1 Hour
12.0 - 12.2	25-50%	16 volts/7 amps	2 Hours

Maintenance

11.7-12.0	0-25%	14.4 volts/4 amps	3 Hours
11.7 or less	0%	14.4 volts/2 amps	6 Hours or More

Check Hydraulic Oil Level

Service Interval: Every 40 hours

Hydraulic Oil Level

1. Stop engine and wait for all moving parts to stop. Make sure unit is on a level surface.
2. The hydraulic reservoir is located under the rear left cover of the machine. Unscrew the cap and clean the dipstick.
3. Reinsert the dipstick. Do not screw into place. Remove the dipstick and read the oil level.
4. If the oil level is low, fill to the "FULL" mark, Figure 15. **Do Not** overfill.

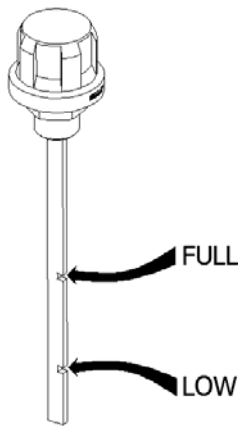

Figure 15. Dipstick Markings

5. Use only **A68 Hydraulic Oil** or appropriate substitute.

Check Tire Pressure

Service Interval: Every 40 hours

1. Stop engine and wait for all moving parts to stop.
2. Check tire pressure and make any necessary adjustments.

Check for Loose Hardware

Service Interval: Before each use or daily

1. Stop engine, wait for all moving parts to stop, and remove key.
2. Visually inspect machine for any loose hardware or any other possible problem. Tighten hardware or correct the problem before operating.

Checking Rotor Shaft Tines

Service Interval: Before each use or daily

1. Ensure the rotor shaft is off the ground with the lift cylinder completely retracted and engage red handled cylinder lock bar.
2. Stop engine, wait for all moving parts to stop, and remove key.
3. Clean rotor and shaft free from debris.
4. Inspect for loose or broken tines.

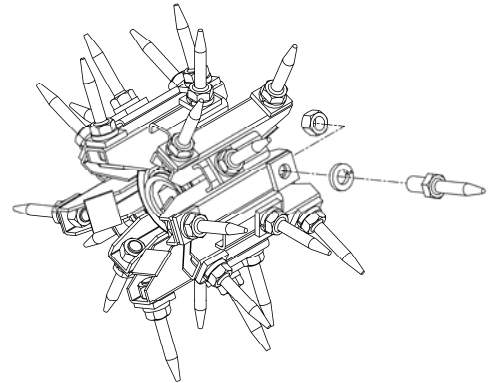

Figure 16. Rotor

5. Tines are assembled as shown in Figure 16. The tines are removed and installed using an extra deep impact socket (AE60T003), provided with shaft. **Torque tines to 210 ft-lbs.**

⚠ CAUTION

For safety reasons, each maintenance operation must be performed with the machine off and key removed.

Maintenance

Check Condition of Belts

Service Interval: Every 40 hours

1. Stop engine, wait for all moving parts to stop, and remove key.
2. Check under all covers to check belts going to pump, gearbox, and rotor shaft.
3. Replace any belts in need of repair.

Lubricate Grease Fittings

Service Interval: Every 50 hours

1. Stop engine, wait for all moving parts to stop, and remove key.
2. Lubricate all three fittings located on the lift axle at each bushing. Refer to parts breakdown of lift axle for assistance.

Check Spark Plugs

Service Interval: Every 160 hours

Remove spark plugs, check condition and reset gaps, or replace with new plugs. See Engine Owner's Manual.

Check Fuel Filter

Service Interval: As required

A fuel filter is installed between the tank and the engine. Replace when necessary.

Change Hydraulic System Filter

Service Interval: After the first 250 hours, Yearly thereafter

1. Stop engine, wait for all moving parts to stop, and remove key.
2. With the lift cylinder fully retracted, use the red handled lock-out bar to pin the cylinder into

place and prevent the machine from leaking down.

⚠ CAUTION

Failure to lock out the lift cylinder while performing maintenance on the hydraulic system can result in serious injury.

3. Carefully clean area around filter. It is important that no dirt or contamination enters the hydraulic system.
4. Use proper tools to slowly remove the hose and fittings from the in-line filter. Pay special attention to the direction the filter is oriented.
5. Install new filter using proper tools and torque on adapters and fittings.
6. Operate machine for several minutes
7. Check oil level.

Note: Do Not change hydraulic system's oil (except for what can be drained when changing filter), unless it is required due to contamination or overheating. Changing oil unnecessarily could contaminate hydraulic system.

⚠ WARNING

Hydraulics fluids escaping under pressure can penetrate skin and cause injury.

- Keep your body and hands away from pin hole leaks.

⚠ CAUTION

Hydraulics Couplers, hydraulic lines/valves, and hydraulic fluids may be hot. If you contact hot components you may be burned.

- Wear gloves when operating the hydraulic couplers.
- Allow the machine to cool before touching hydraulic components.
- Do not touch hydraulic spills.

Maintenance

Clean Engine

Service Interval: Before each use or daily

⚠ CAUTION

Excessive debris can cause the engine and hydraulic system to overheat which can create a fire hazard.

Clean all debris from around the engine and hydraulic pumps daily.

1. Stop engine, wait for all moving parts to stop, and remove key.
2. Clean all debris from rotating engine air intake screen, engine oil cooler, and from around engine shrouding.
3. Remove engine shrouds and Clean cooling fins.

Service Interval: Every 100 hours

1. Stop engine, wait for all moving parts to stop, and remove key.
2. Remove cooling shroud clean-out cover from engine and clean cooling fins. Also clean dirt and oil from external surfaces of engine which can cause improper cooling.
3. Make sure cooling shroud clean-out covers are reinstalled. Operating the engine without cooling shroud clean-out covers will cause engine damage due to overheating.

Waste Disposal

Motor Oil Disposal

Engine oil and hydraulic oil are both pollutants to the environment. Dispose of used oil at a certified recycling center or according to your state and local regulations.

Battery Disposal

⚠ DANGER

Battery electrolyte contains sulfuric acid, which is poisonous and can cause severe burns. Swallowing electrolyte can be fatal or if it touches skin can cause severe burns.

- Wear safety glasses to shield eyes, and rubber gloves to protect skin and clothing when handling electrolyte.
- Do Not swallow electrolyte.

Federal law states that batteries should not be placed in the garbage. Management and disposal practices must be within relevant federal, state, or local laws.

If a battery is being replaced or if the unit containing the battery is no longer operating and being scrapped, take the battery to a local certified recycling center. If no local recycling is available return the battery to any certified battery reseller.

Maintenance

Rotor Shaft Service

When rotor replacement is needed or repaired on an Aera-vator shaft, the following steps must be taken in order to properly maintenance these items.

Rotor Shaft Disassembly

1. With the rotor shaft removed from the frame and secured on the floor, remove the 1-1/8" hex jam nut from the shaft end nearest to the damaged component (use Figure 16 for visual reference).
2. Only remove the rotors and spacers required to reach the damaged component. Wipe the shaft clean before each rotor is removed. Each rotor bearing has two separate cones with a hex bore adapter pressed in each. Each cone is held in position by an internal grease seal, which allows the cones to be moved apart slightly. When they are moved apart any dirt allowed inside the hex adapters can fall between the cones and contaminate the bearing. If the cones are forced apart the internal seals become ruined and irreplaceable.
3. Clean and inspect parts as they are removed and set aside in their order of removal to simplify re-assembly.

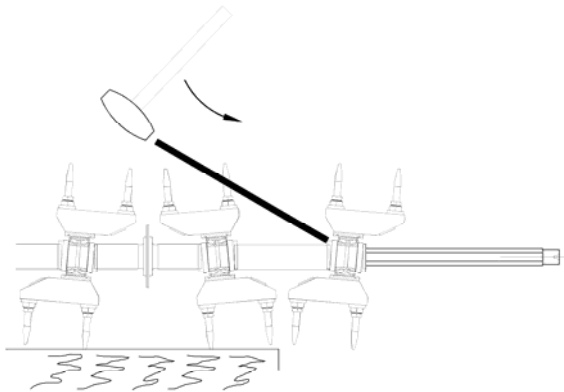

Figure 17 Rotor Shaft Disassembly

CAUTION

To apply force against the rotors or tines while removing rotor assemblies will ruin the irreplaceable internal rotor bearing seals. Use a blunt bar against the thick face of the bearing adapter to drive the rotors off the shaft.

Rotor Hub Disassembly

1. With a pry bar remove the external seals Figure 18) on both sides. Generally, seals are damaged and are not reused.
2. Remove the snap rings on both sides.
3. Press used bearing and adapter assembly out.

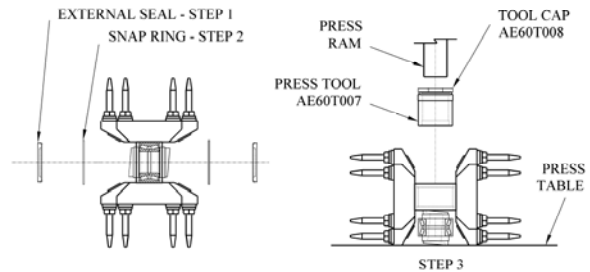

Figure 18. Rotor Assembly

Rotor Hub Re-Assembly

(Keep all components clean to prevent bearing contamination.)

1. Install internal snap ring in one side of rotor hub. **Be sure snap rings expand full depth into grooves.**
2. Press new bearing and adapter assembly down tight against snap ring. If bearing is loose in hub the rotor should be replaced.
3. Install snap ring in the other side.
4. Apply a ribbon of general-purpose grease between the snap ring ID and bearing adapter OD on both ends of the rotor hub.
5. With the press tool inverted to fit the external seals, press the seals in both ends of the rotor **with the lips out**. Wipe off excess grease. Be sure seals are not bent or cut and are seated firmly. **If the seals are not tight, use a hammer and punch to stake the hub faces at about 90° intervals.**

Rotor Shaft Re-Assembly

(Read this section thoroughly before beginning.)

Maintenance

⚠ CAUTION

IF THE BEARING ADAPTERS ARE NOT PRECISELY TIMED 180 DEGREES APART IN EACH ROTOR; SERIOUS DAMAGE WILL RESULT.

Timing the Rotor Shaft

1. Use marker pen to assist with aligning timing marks between rotors. Mark two rotor shaft flats 180 degrees apart next to the threaded end (see Figure 19 and Figure 20). The marked flats would have to align with the timing marks on any rotors not removed during servicing.
2. Install the required components in the sequence shown in parts break down (page 35), double-checking the timing mark locations and spacer as each rotor is installed.

⚠ CAUTION

CLEAN THE ROTOR SHAFT THOROUGHLY REMOVING ANY BURRS THAT WOULD KEEP THE ROTOR ASSEMBLIES FROM SLIDING ON FREELY. IF A BEARING ADAPTER JAMS, THE INTERNAL BEARING SEAL COULD BE FORCED OUT AND IT IS NOT REPLACEABLE.

NOTE: The spacers must be fully seated in each adapter counterbore before tightening. Do Not forget to place the bearing stampings on each of the shaft bearings during reassembly.

3. Replace the 1-1/8" hex jam nut and rotate each rotor occasionally as the nut is torqued to 350 ft-lbs. If any rotor locks up, the bearing adapters in the rotor are probably not phased 180 degrees apart or the spacers are not fully seated.

Timing Marks Phased 180° Apart

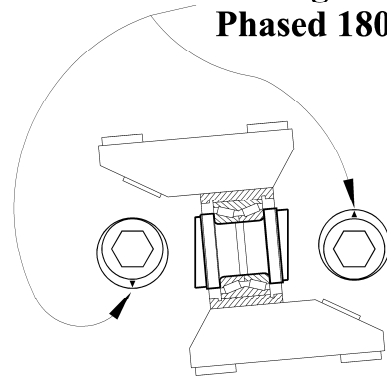

Figure 19 Rotor Timing Mark Reference

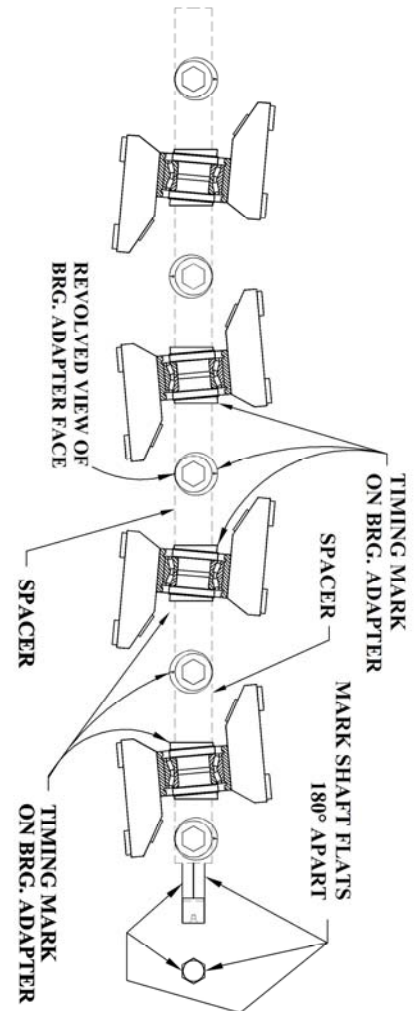

Figure 20. Timing First Four Rotors

WARRANTY INFORMATION

ONE YEAR LIMITED WARRANTY

FIRST PRODUCTS INC. WARRANTS THIS PRODUCT TO BE FREE OF DEFECTS IN MATERIALS AND WORKMANSHIP FOR A PERIOD OF TWELVE MONTHS FROM THE ORIGINAL DELIVERY DATE. THIS WARRANTY DOES NOT COVER PARTS CAUSED TO BE DEFICIENT DUE TO NORMAL WEAR, MISUSE, ACCIDENTS, OR LACK OF PROPER MAINTENANCE.

ANY PARTS THOUGHT TO BE DEFECTIVE MUST BE RETURNED TO THE DEALER/DISTRIBUTOR FOR WARRANTY CONSIDERATION JOINTLY WITH FACTORY REPRESENTATIVES. A RETURN AUTHORIZATION NUMBER MUST BE OBTAINED AND CLEARLY MARKED ON ALL PACKAGES OF PARTS REQUIRING RETURN TO THE FACTORY.

THE OBLIGATION OF FIRST PRODUCTS INC. UNDER THIS WARRANTY SHALL BE EXCLUSIVELY LIMITED TO REPLACEMENT OF PARTS DETERMINED TO BE DEFECTIVE BY FIRST PRODUCTS INC. WITH FREIGHT PREPAID. IN NO EVENT SHALL FIRST PRODUCTS INC. BE LIABLE FOR INDIRECT, INCIDENTAL, OR CONSEQUENTIAL DAMAGES IN CONNECTION WITH THE USE OF THIS PRODUCT.

FIRST PRODUCTS INC. RESERVES THE RIGHT TO MAKE CHANGES OR ADD IMPROVEMENTS TO ITS PRODUCTS AT ANY TIME WITHOUT OBLIGATION TO MAKE SUCH CHANGES OR IMPROVEMENTS ON PRODUCTS SOLD PREVIOUSLY.

WARRANTY CLAIMS ARE PAID USING A JOB STANDARD (AUTHORIZING MAN HOURS) USING THE APPROPRIATE TIME FRAME ALLOWED FOR EACH PART REPLACED OR LABOR FUNCTIONS PERFORMED. THIS JOB STANDARD LIMITS THE MAN HOURS AUTHORIZED BY TASK. IT DOES NOT SET A SPECIFIC HOURLY RATE BUT LIMITS THE AUTHORIZED MAN HOURS THAT WILL BE PAID BY EACH TASK. MILEAGE IS NOT PAID.

For the Engine, refer to engine booklet in Parts Tube.

Power Transmission Accessories Group

ITEM	PART NO	DESCRIPTION	QTY	ITEM	PART NO	DESCRIPTION	QTY
1	AE50-085	1/4 X 2 (1045) KEY	1	17	UA27-278	SPRING REST	1
2	HW01008016G5ZPC	1/4 X 1/2 HHCS	3	18	UA50-044	2B X 5.50 ELECTRIC CLUTCH	1
3	HW01008024G5ZPC	1/4 X 3/4 HHCS	2	19	UA50-048	AX26 BELT	1
4	HW01010112G5ZPC	5/16 X 3 1/2 HHCS	1	20	UA50-050	AK39 X 1/2 BORE	1
5	HW01014064G5ZPF	7/16 X 2 HHCS FINE THREAD	1	21	UA50-060	1 1/2" GROMMET	1
6	HW01M080358.8ZC	8MM X 35MM HHCS	2	22	UA50-063	3/8 X 1 1/2 U-BOLT	4
7	HW22008G5ZPC	1/4 FLANGE LOCK NUT	6	23	UA50-064	ENGINE, 28 HP HORIZONTAL SHAFT	1
8	HW22010G5ZPC	5/16 FLANGE LOCK NUT	1	24	UA50-065	GX690 MUFFLER	1
9	HW22012G5ZPC	3/8 FLANGE LOCK NUT	8	25	UA50-090	OIL FILTER; GX690	1
10	HW32014G5ZP	7/16 LOCKWASHER	1	26	UA50-091	AIR FILTER; GX690	1
11	UA26-020	CLUTCH BRACE	1	27	UA50-105	3/16 HOSE LOOP	1
12	UA27-125	CABLE MOUNT	1	28	UA50-106	THROTTLE SPRING	1
13	UA26-045	3/8 X 1/2 STAND-OFF	2	29	UA80-106	SHIELD BULKHEAD	1
14	UA27-203	SHIELD RECEIVER	1	30	UA81-086	THROTTLE CABLE ASSEMBLY	1
15	UA27-217	CLUTCH SPACER	1	31	VC50-003	BX64 BELT	2
16	UA27-245	CABLE PEDESTAL	1				

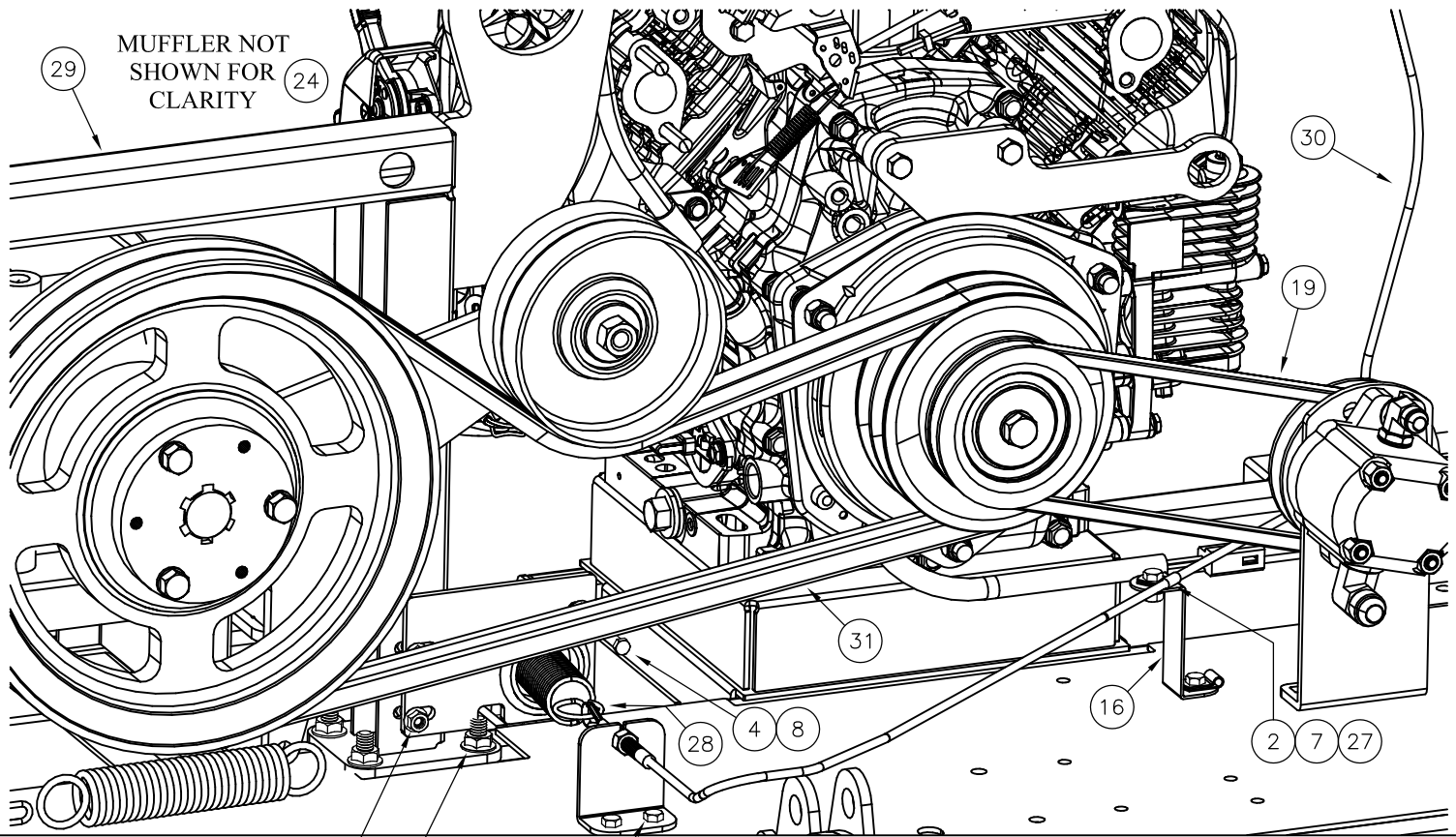

UNDER COVER

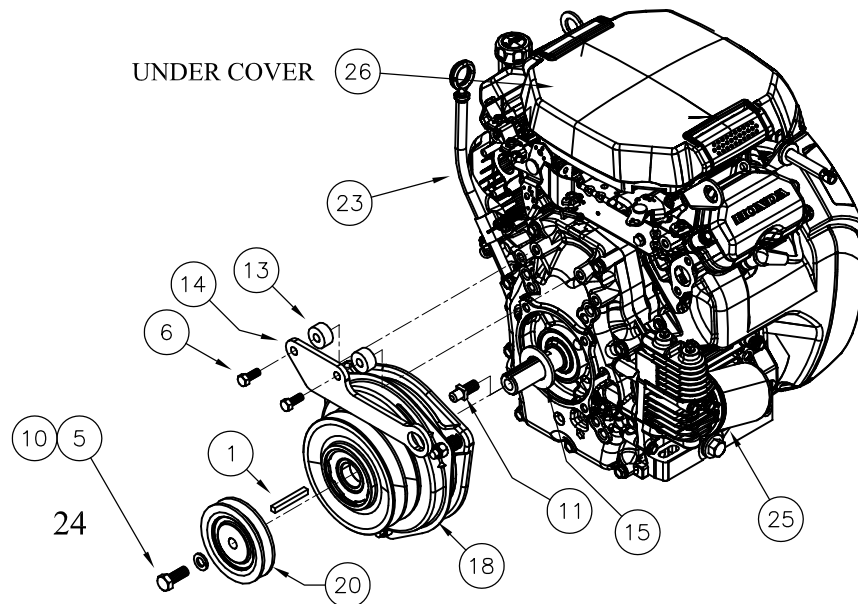

Power Transmission Group

ITEM	PART NO	DESCRIPTION	QTY	ITEM	PART NO	DESCRIPTION	QTY
1	AE26-035	JACK SHAFT 40L	1	35	HW25016G5ZPC	1/2 JAM NUT	1
2	AE50-048	1 1/8 BEARING	1	36	HW30012TAZPC	3/8 FLATWASHER	4
3	AE50-053	62mm X 3 HOLE HVY. FLANGE	2	37	HW31016TAZP	1/2 SAE FLAT WASHER	1
4	AE50-085	1/4 X 2 (1045)	2	38	HW32012G5ZP	3/8 LOCK WASHER	4
5	AE50-100	5/16 PROOF COIL CHAIN X 7 LINKS	1	39	HW32016G5ZPC	1/2 LOCK WASHER	4
6	AG50-016	#50-2 X 18 P CHAIN	1	40	HW32024G8ZP	3/4 HD LOCKWASHER	1
7	AG80-011	50B18 X 1 3/8 6B SPKT	1	41	UA24-056	7/16" SPACER	2
8	FL54-001	FL72 GEARBOX	1	42	UA24-058	1/2 X 3/4 X 4 1/2 BUSHING	1
9	HW01008016G5ZPC	1/4 X 1/2 HHCS	2	43	UA24-065	CONNECTOR BUSHING	1
10	HW01012040G5ZPC	3/8 X 1 1/4 HHCS	3	44	UA24-068	1/2 ID X 1 1/16 LONG SPACER	1
11	HW01012128G5ZPC	3/8 X 4 HHCS	4	45	UA27-125	CABLE MNT.	1
12	HW01016040G5ZPC	1/2 X 1 1/4 HHCS	2	46	UA27-181	SHEAVE COVER	1
13	HW01016048G5ZPC	1/2 X 1 1/2 HHCS	1	47	UA27-186	SPRING BASE	1
14	HW01016112G5ZPC	1/2 X 3 1/2 HHCS	6	48	UA27-198	IDLER ARM	1
15	HW01016192G5ZPC	1/2 X 6 HHCS	1	49	UA27-264	CHAIN TENSIONER PLATE	1
16	HW01024112G5ZPC	3/4 X 3 1/2 HHCS	1	50	UA50-028	1/2 X 2 X 3/16 WASHER	1
17	HW01M080208.8ZC	M8 X 20 HHCS	4	51	UA50-028	1/2 X 2 X 3/16 WASHER	1
18	HW01M120308.8ZC	M12 X 30 HHCS	4	52	UA50-034	4B 6.9 X 1 1/8 BORE SHEAVE	1
19	HW03008024G5ZPC	1/4 X 3/4 CARRIAGE BOLT	1	53	UA50-049	1 3/8 SPLINE BUSHING	1
20	HW03010024G5ZPC	5/16 X 3/4 CARRIAGE BOLT	4	54	UA50-052	2B11 QD SHEAVE	1
21	HW03012032G5ZPC	3/8 X 1 CARRIAGE BOLT	6	55	UA50-053	2 3/8 X 6 5/16 PRESSURE SPRING	1
22	HW03016032G5ZPC	1/2 X 1 CARRIAGE BOLT	3	56	UA50-064	ENGINE, 28 HP HORIZONTAL SHAFT	1
23	HW03016096G5ZPC	1/2 X 3 CARRIAGE BOLT	1	57	UA50-071	5 X 2 IDLER	1
24	HW03016128G5ZPC	1/2 X 4 CARRIAGE BOLT	1	58	UA50-103	INTER. IDLER SPRING	1
25	HW07010032GPLC	5/16 X 1 SQR HD SET SCREW	4	59	UA50-136	#2 CHAIN X 4 LINKS	1
26	HW17016128G5ZPC	1/2 X 4 TAP BOLT	1	60	UA80-095	IDLER ARM	1
27	HW20012G5ZPC	3/8 HEX NUT	4	61	UA80-114	IDLER/GB CONNECTOR	1
28	HW20024G5ZPC	3/4 HEX NUT	1	62	UA80-120	CENTER MOUNT	1
29	HW22008G5ZPC	1/4 FLANGE LOCK NUT	3	63	UA80-139	#50B18 SPROCKET	1
30	HW22010G5ZPC	5/16 FLANGE LOCK NUT	4	64	VC50-003	BX64 BELT	2
31	HW22012G5ZPC	3/8 FLANGE LOCK NUT	6	65	VC50-015	3 1/4 WIDE X 5 DIA. IDLER	1
32	HW22016G5ZPC	1/2 FLANGE LOCK NUT	14	66	VC50-038	BX60 BELT	4
33	HW24016GBZPC	1/2 STOVER LOCK NUT	2				
34	HW25010G5ZPC	5/16 JAM NUT	4				

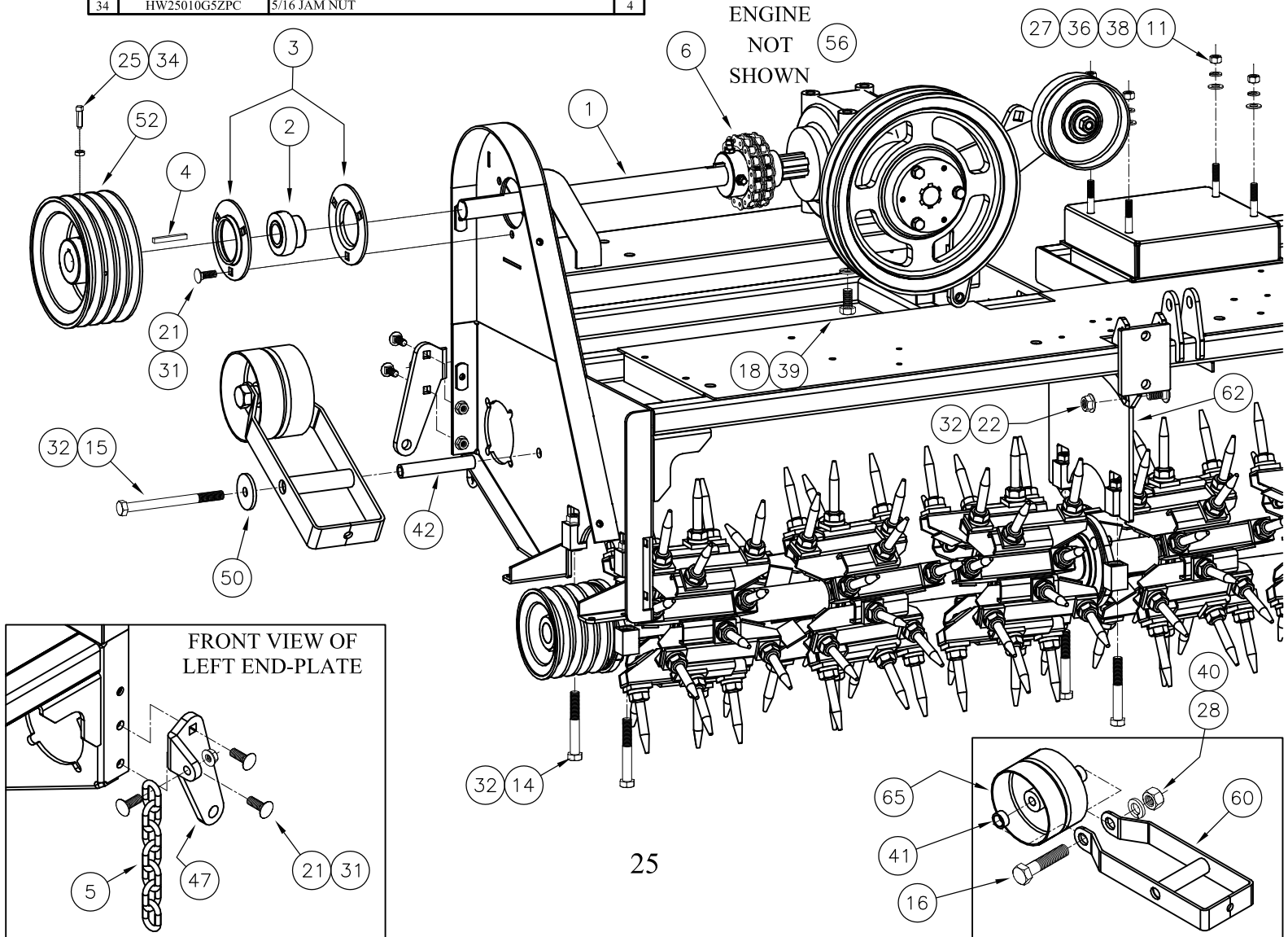

Power Transmission Group

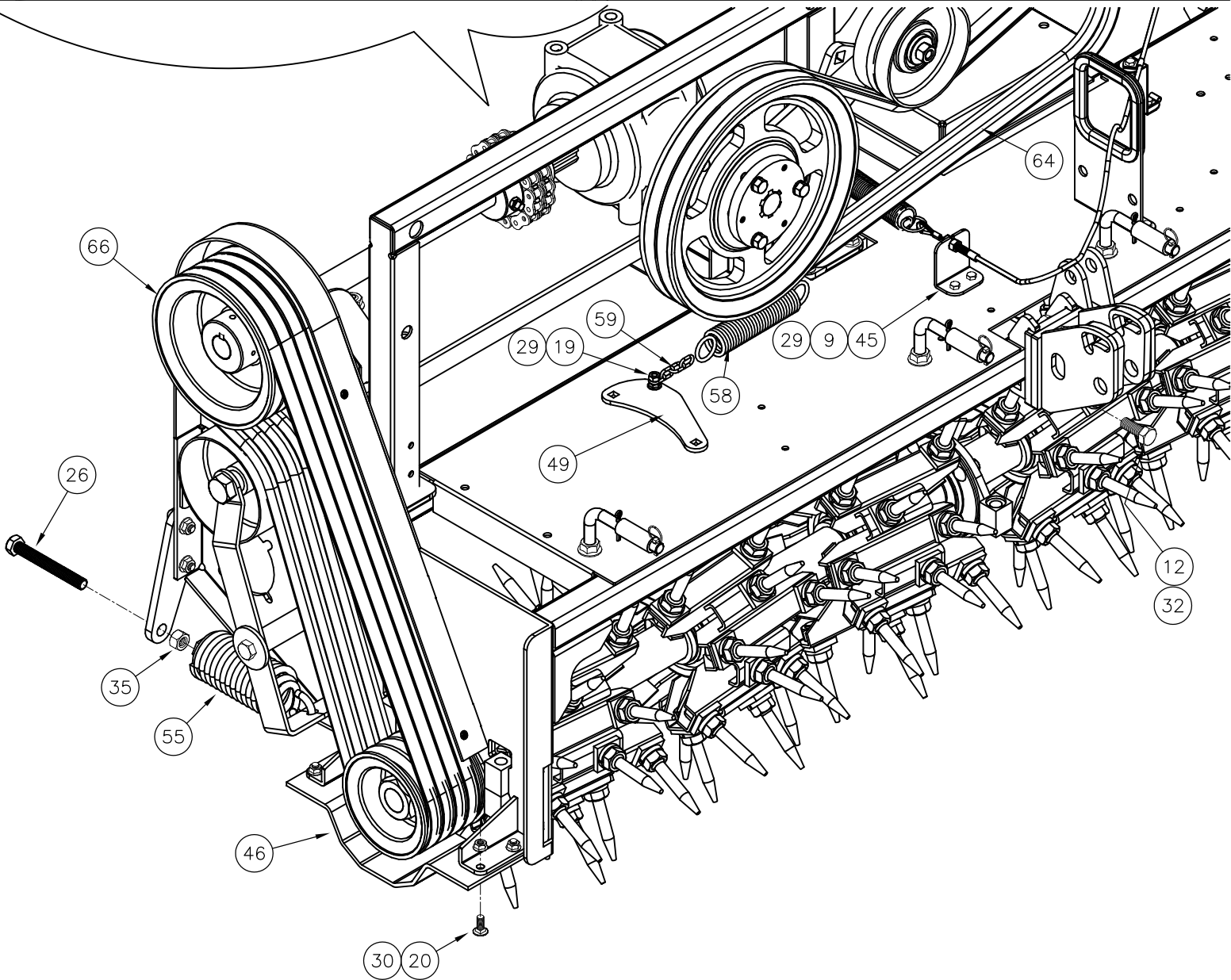
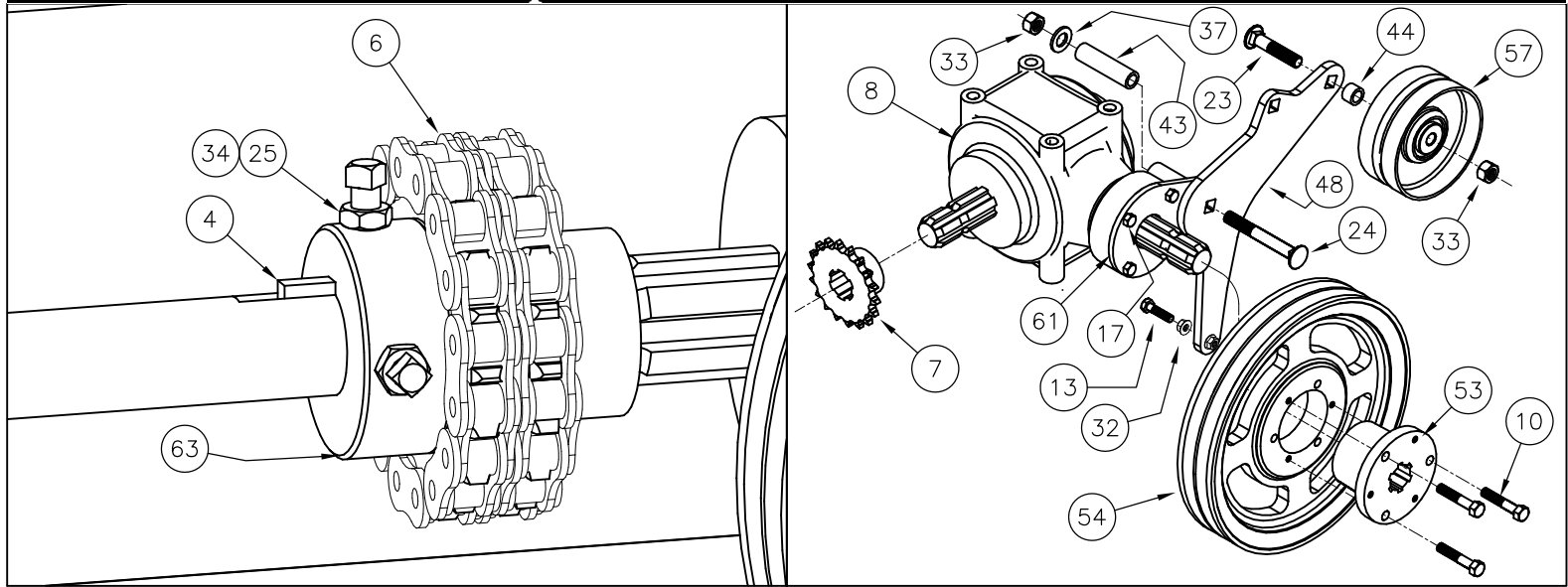

Fuel Tank and Electrical Group

ITEM	PART NO	DESCRIPTION	QTY	ITEM	PART NO	DESCRIPTION	QTY
1	AE50-265	RELAY	1	22	UA50-084	SOLINOID CONNECTOR	2
2	HW01008016G5ZPC	1/4 X 1/2 HHCS	6	23	UA50-085	GROUND CABLE, 12"	1
3	HW01008024G5ZPC	1/4 X 3/4 HHCS	2	24	UA50-086	CABLE LOOP - 3/8	1
4	HW01008032G5ZPC	1/4 X 1 HHCS	2	25	UA50-089	RETURN HOSE COUPLER	1
5	HW03008024G5ZPC	1/4 X 3/4 CARRIAGE BOLT	4	26	UA50-092	3/8" TO 1/4" ADAPTER	1
6	HW03010024G5ZPC	5/16 X 3/4 CARRIAGE BOLT	4	27	UA50-096	FUEL FILTER; GX690	1
7	HW04008024PLC	1/4 X 3/4 HEX HEAD SELF THREAD	1	28	UA50-105	3/16 HOSE LOOP	1
8	HW10M04010SSC	M4 X 10 SS FHCS	4	29	UA50-114	FUEL TANK W/ PORT	1
9	HW22008G5ZPC	1/4 FLANGE LOCK NUT	18	30	UA50-137	SWITCH BOX, HAND HELD	1
10	HW22010G5ZPC	5/16 FLANGE LOCK NUT	4	31	UA50-138	SWITCH JUMPER WIRE	1
11	HW30008TAZP	1/4 FLAT WASHER	2	32	UA50-139	3/16 INSULATED FEMALE QUICK CONN.	4
12	UA26-033	BATTERY U-BOLT	1	33	UA50-145	1/2 METAL LOOP CLAMP	1
13	UA27-160	GAS TANK STRAP	2	34	UA50-157	BATTERY CABLE	1
14	UA27-179	SWITCH BOX COVER	1	35	UA50-158	GX690 REGULATOR RECTIFIER	1
15	UA50-066	1/2" GROMMET	4	36	UA50-160	PURGE LINE, 41"	1
16	UA50-067	1/2" FUEL CLAMP	6	37	UA50-163	5/8" FUEL CLAMP	2
17	UA50-070	FUEL LINE, 28"	1	38	UA80-088	FUEL TANK MOUNT	1
18	UA50-073	CARBON CANISTER	1	39	WB50-083	SWITCH, 2 POS, ON - OFF	1
19	UA50-074	CANISTER STRAP	2	40	WB50-090	BATTERY	1
20	UA50-082	PLUG ASSEMBLY	1	41	WB50-182	CARB LINE, 24"	1
21	UA50-083	SOCKET WIRE ASSY	1	42	WB50-240	SWITCH, MOMENTARY, OFF - (ON)	2

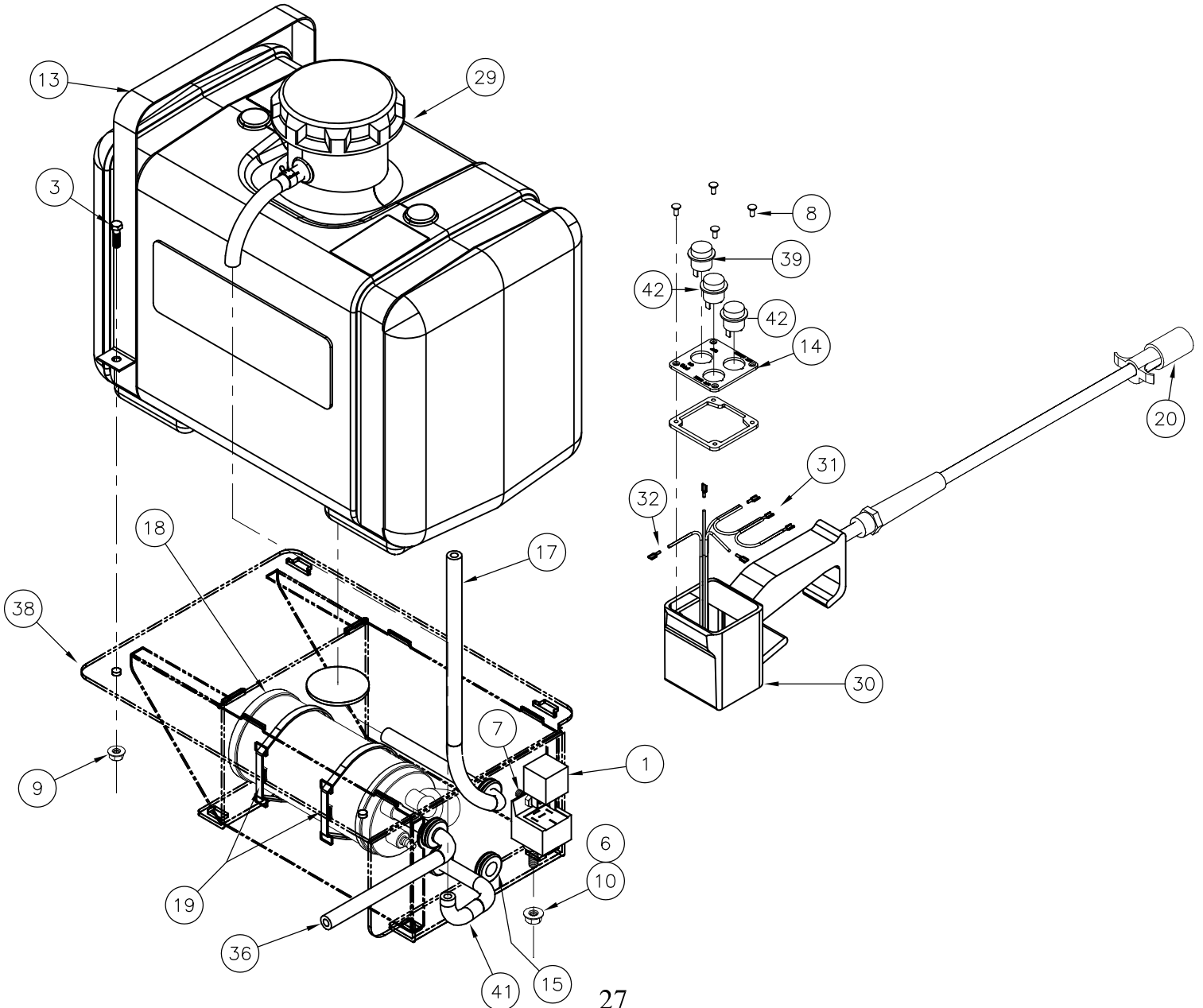

Hydraulics Group

ITEM	PART NO	DESCRIPTION	QTY	ITEM	PART NO	DESCRIPTION	QTY
1	AE50-156	BRIDGE PIN	1	26	UA50-056	VALVE ASSEMBLY	1
2	FL50-008	CAT. 0 TOP LINK	1	27	UA50-057	IN-LINE FILTER	1
3	HW01008080G5ZPC	1/4 X 2 1/2 HHCS	2	28	UA50-058	AK39 X 1/2 BORE	1
4	HW01010080G5ZPC	5/16 X 2 1/2 HHCS	1	29	UA50-061	KEEPER SPRING	1
5	HW01012032G5ZPC	3/8 X 1 HHCS	2	30	UA50-075	TRAIL LIFT CYLINDER	1
6	HW01020080G5ZPC	5/8 X 2 1/2 HHCS	2	31	UA50-076	HYD. HOSE; RES.-PUMP	1
7	HW03010024G5ZPC	5/16 X 3/4 CARRIAGE BOLT	2	32	UA50-077	HYD. HOSE; PUMP-PORT P	1
8	HW03010032G5ZPC	5/16 X 1 CARRIAGE BOLT	4	33	UA50-078	HYD. HOSE; PORT A-CYLINDER	1
9	HW03016032G5ZPC	1/2 X 1 CARRIAGE BOLT	2	34	UA50-079	HYD. HOSE; PORT B-CYLINDER	1
10	HW08010016PLC	5/16 X 1/2 SOCKET SETSCREW	1	35	UA50-080	HYD. HOSE; TANK-PORT T	1
11	HW22008G5ZPC	1/4 FLANGE LOCK NUT	2	36	UA50-081	ADAPTER, #6FJIC-#6MORB	1
12	HW22010G5ZPC	5/16 FLANGE LOCK NUT	8	37	UA50-152	HANDLE GRIP	1
13	HW22012G5ZPC	3/8 FLG. LOCKNUT	2	38	UA50-153	CHECK VALVE - POPPET	1
14	HW22016G5ZPC	1/2 FLANGE LOCK NUT	2	39	UA50-154	PRESSURE RELEIF VALVE	1
15	HW22020G5ZPC	5/8 FLANGE LOCK NUT	4	40	UA50-155	SOLENOID VALVE	2
16	HW27020056ZP	5/8 X 1 3/4 CLEVIS PIN	1	41	UA50-156	BREATHER CAP	1
17	UA26-038	CYLINDER PIN	2	42	UA50-159	COUNTER BALANCE VALVE 4:1	1
18	UA27-187	SWAY MOUNT	1	43	UA50-161	SOLENOID VALVE COIL	2
19	UA27-188	PUMP PLATE	1	44	UA80-086	TRAIL FRAME	1
20	UA27-227	CYLINDER LOCK BAR	1	45	UA80-112	RESERVOIR	1
21	UA50-007	3/16 X 1 1/4 LYNCH PIN	2	46	WB50-029	ADAPTER, STRAIGHT #6MJIC-#6MORB	4
22	UA50-045	BALL VALVE; 1/2 FPT	1	47	WB50-031	ADAPTER, 90° #6MJIC-#6MORB	3
23	UA50-046	ADAPTER; 2404-08-08	1	48	WB50-209	ADAPTER, 90° #8MJIC-#8MORB	1
24	UA50-051	CYLINDER PUMP	1	49	WB50-210	ADAPTER, STRAIGHT, #8MJIC-#8MORB	1
25	UA50-054	ADAPTER; 6806-08-08-NWO	1				

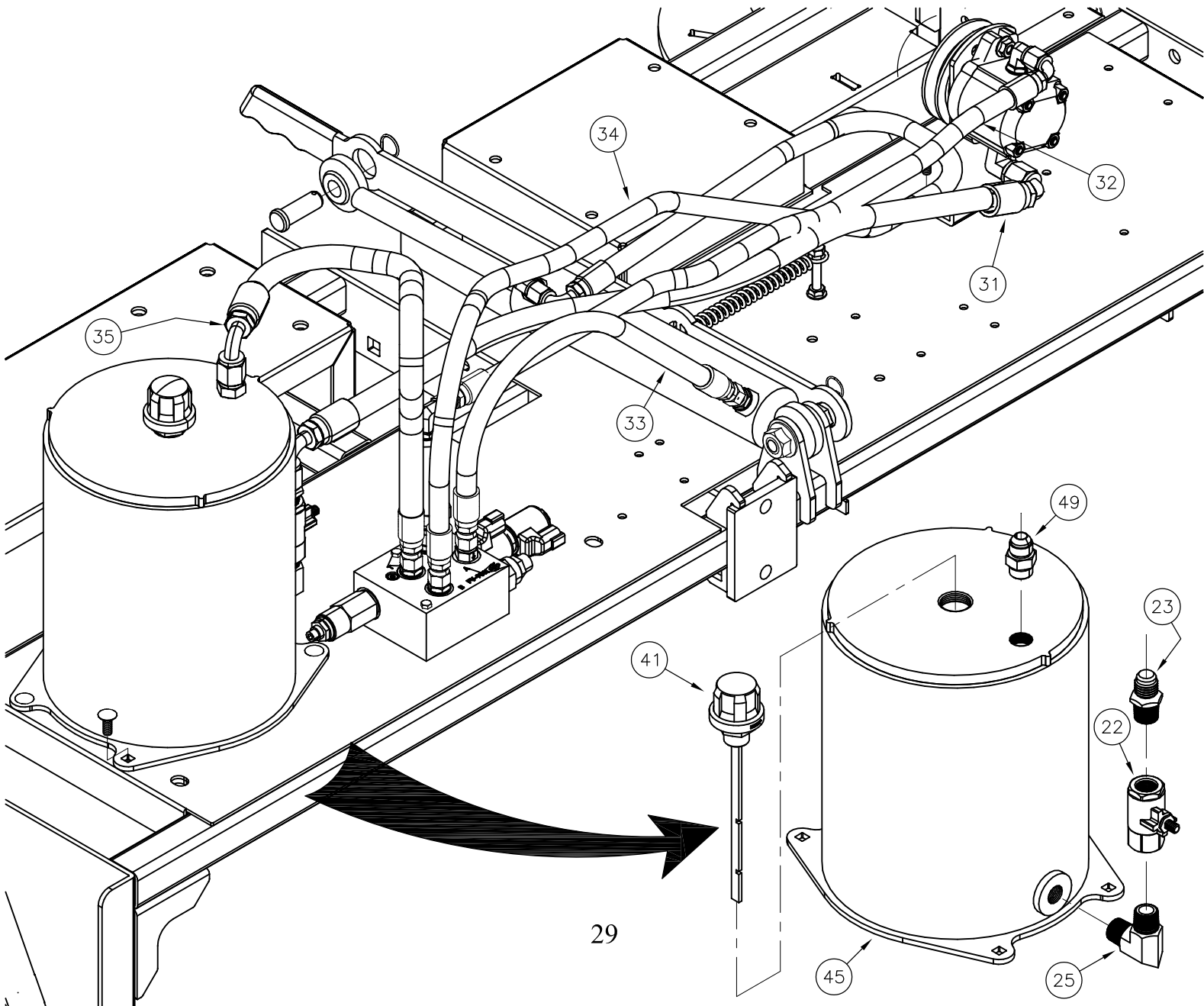

Lift Axle Group

ITEM	PART NO	DESCRIPTION	QTY	ITEM	PART NO	DESCRIPTION	QTY
1	AE50-156	BRIDGE PIN	2	27	HW40005048ZP	5/32 X 1 1/2 COTTER PIN	2
2	FA50-088	WHEEL ASSEMBLY	2	28	HW5000890F	1/4 - 28 X 90° GREASE FITTING	5
3	FA50-098	1 3/8 TAPER ROLLER BRG/RACE	2	29	HW6002405607GPL	3/4 X 1 3/4 X 7 GA M.B.	2
4	FA50-099	1 1/4 TAPER ROLLER BRG/RACE	2	30	HW70024PLF	3/4 CASTLE NUT	2
5	FA50-100	5 X 5 1/2 HUB	2	31	UA24-051	2 1/2" LOCK COLLAR	2
6	FA50-101	1 3/4 X 69mm SEAL	2	32	UA27-193	PIN BAR	2
7	FA50-102	2 7/16 DUST CAP	2	33	UA27-280	1/2 X 2 X 1/2 WASHER	2
8	HW01016040G5ZPC	1/2 X 1 1/4 HHCS	2	34	UA50-043	UA TRAIL SPINDLE	2
9	HW01016048G5ZPC	1/2 X 1 1/2 HHCS	2	35	UA50-055	2" COUPLER X 2 1/2" CHANNEL	1
10	HW01016056G5ZPC	1/2 X 1 3/4 HHCS	1	36	UA50-059	2 1/2 VR1 SEAL	3
11	HW01016064G5ZPC	1/2 X 2 HHCS	1	37	UA50-132	3/4 X 3 1/2 BENT ARM PIN	2
12	HW01016112G5ZPC	1/2 X 3 1/2 HHCS	4	38	UA50-144	SAFETY TOWING CHAINS	1
13	HW01016144G5ZPC	1/2 X 4 1/2 HHCS	2	39	UA50-146	CABLE HOLDER	4
14	HW01024064G5ZPC	3/4 X 2 HHCS	1	40	UA80-089	TONGUE SWIVEL	1
15	HW03012032G5ZPC	3/8 X 1 CARRIAGE BOLT	8	41	UA80-090	LIFT AXLE	1
16	HW03016032G5ZPC	1/2 X 1 CARRIAGE BOLT	3	42	UA80-091	LIFT ARM W/ ANTI-TIP BRACKETS-LEFT	1
17	HW04008024G5ZPC	1/4 X 3/4 HEX HEAD SELF TRD	4	43	UA80-092	CLUTCH PIVOT	1
18	HW06010024G5ZPC	5/16 X 3/4 HEX FLG LOCKING SCREW	8	44	UA80-093	PIVOT CATCH	1
19	HW08016016PLC	1/2 X 1/2 SET SCREWS	2	45	UA80-096	PIVOT JOURNAL	2
20	HW22010G5ZPC	5/16 FLANGE LOCK NUT	4	46	UA80-097	CENTER PIVOT	1
21	HW22012G5ZPC	3/8 FLANGE LOCK NUT	8	47	UA80-142	TONGUE	1
22	HW22016G5ZPC	1/2 FLANGE LOCK NUT	6	48	UA80-143	LIFT ARM W/O ANTI-TIP BRACKETS-RIGHT	1
23	HW24016GBZPC	1/2 STOVER LOCK NUT	8	49	UA80-144	ANTI-TIP LEG	1
24	HW25024G5ZPC	3/4 JAM NUT	1	50	UA80-145	UA60T FENDER, LH	1
25	HW26016G5ZPF	1/2 LUG NUT	10	51	UA80-146	UA60T FENDER, RH	1
26	HW32016G5ZP	1/2 LOCK WASHER	2				

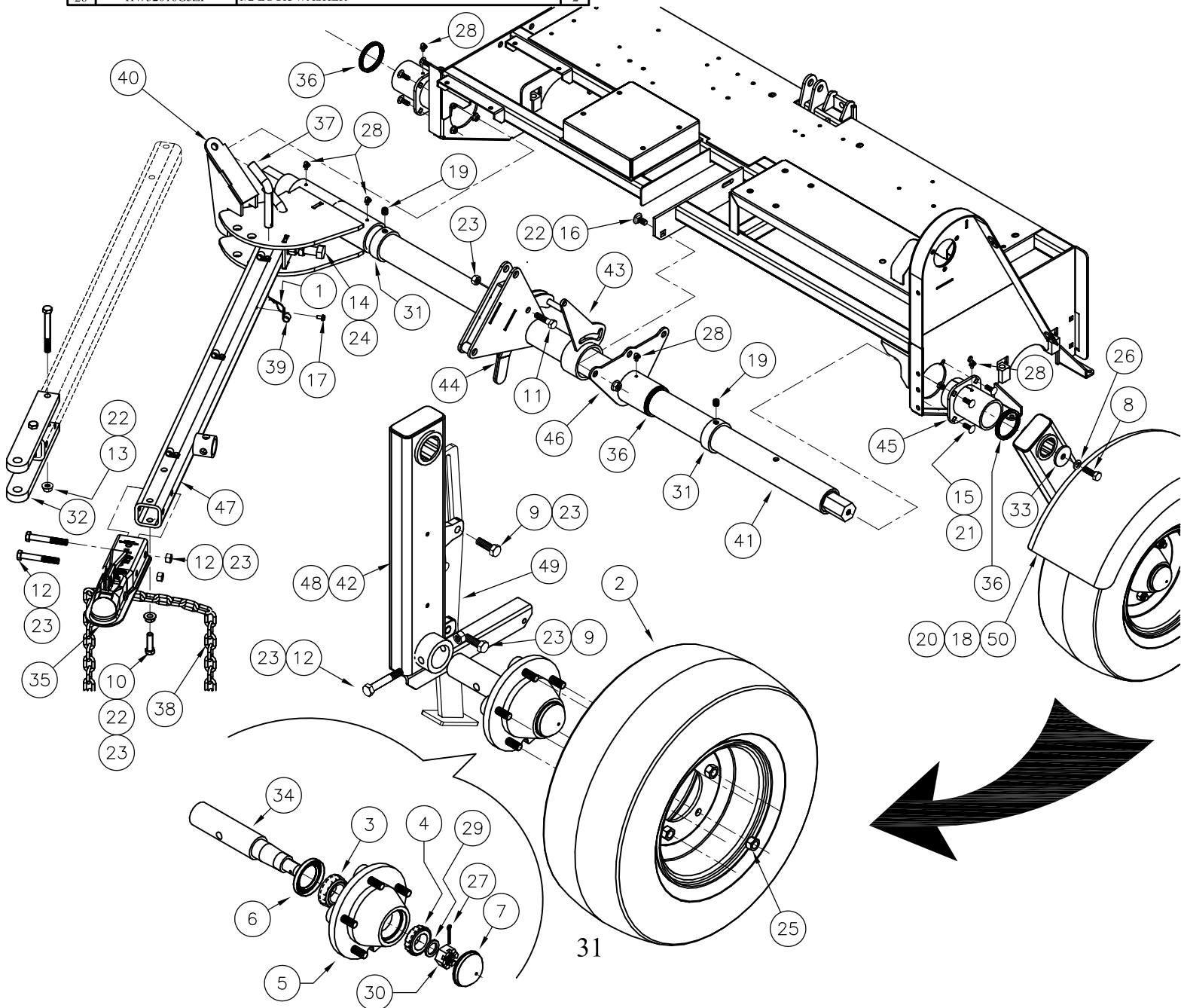

Covers & Decals Group

ITEM	PART NO	DESCRIPTION	QTY	ITEM	PART NO	DESCRIPTION	QTY
1	AE50-032	U.S. PATENT DECAL	1	15	UA26-032	LOWER RECEIVER	6
2	AE50-035	GREASE WEEKLY DECAL	4	16	UA50-007	3/16 X 1 1/4 LYNCH PIN	6
3	AE50-063	AERA-vator DECAL	1	17	UA50-009	O.M. CANISTER	1
4	AE50-074	GENERAL WARNING DECAL	1	18	UA50-012	UA BELT COVER DECAL	1
5	AE50-076	THROWN OBJECT HAZZARD DECAL	1	19	UA50-029	DECAL; BELT TENSION - UA	1
6	AE50-114	DANGER HAZARD DECAL	1	20	UA50-072	RECEIVER SLEEVE	6
7	FA50-080	RED REFLECTIVE STRIP	2	21	UA50-099	DECAL; CYLINDER LOCK	1
8	HW01008024G5ZPC	1/4 X 3/4 HHCS	2	22	UA50-100	DECAL; UA-60T	1
9	HW06010016G5ZPC	5/16 X 1/2 FLANGE LOCK SCREW	4	23	UA50-101	DECAL; FIRST PRODUCTS	1
10	HW22008G5ZPC	1/4 FLANGE LOCK NUT	2	24	UA50-110	UNIVERSAL SYSTEM LOGO	1
11	HW22016G5ZPC	1/2 FLANGE LOCK NUT	12	25	UA80-111	BELT COVER	1
12	HW40004032ZP	1/8 X 1 COTTER PIN	6	26	UA80-113	COMPONENT PANEL	1
13	SB50-046	LOGO, FP TURF	1	27	UA80-117	FRONT SHROUD	1
14	UA26-031	RECEIVER BUSHING	5	28	UA80-118	REAR SHROUD	1

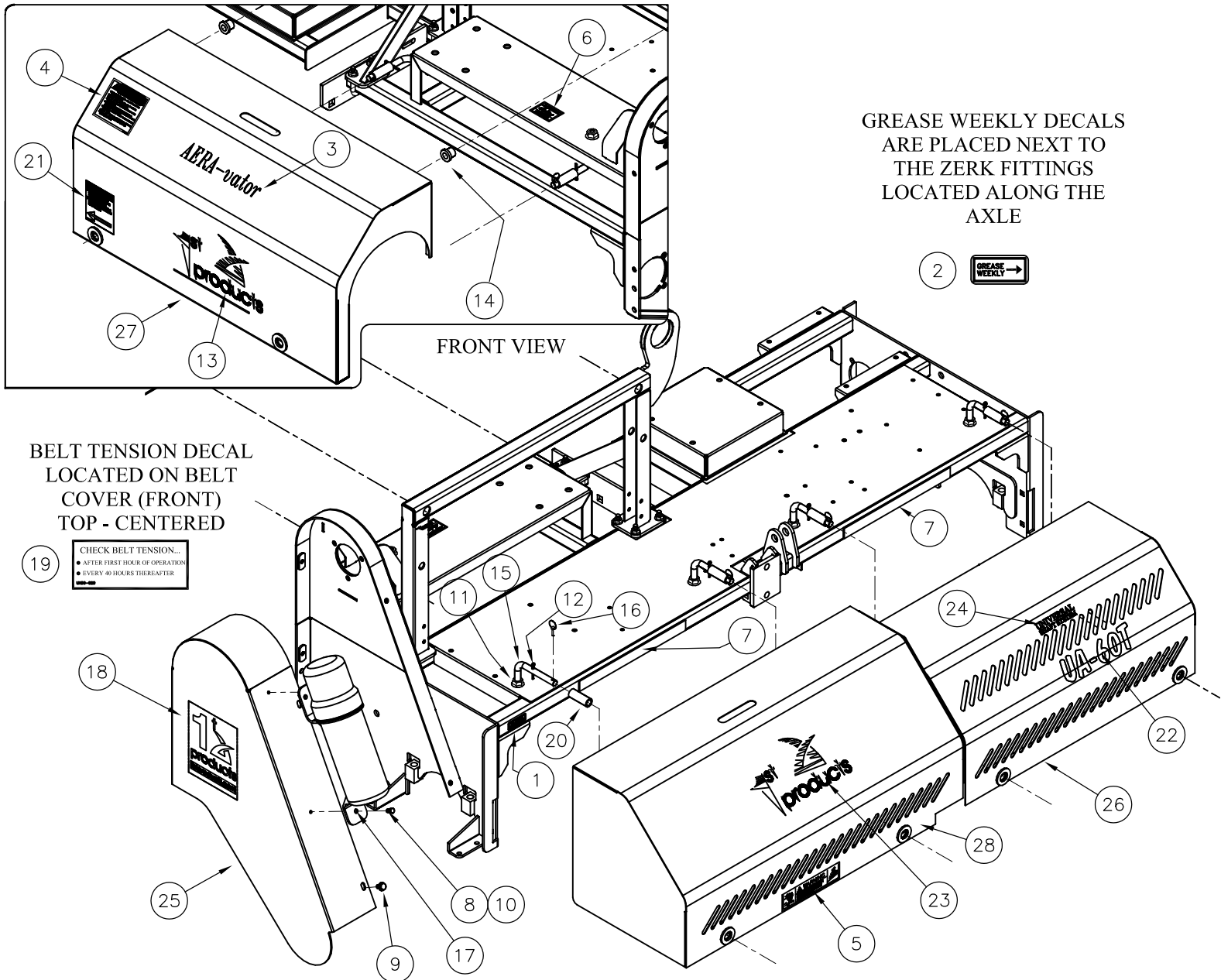

Roller Attachment

ITEM	PART NO	DESCRIPTION	QTY	ITEM	PART NO	DESCRIPTION	QTY
1	AE50-013	52mm X 3 HOLE FLG.	4	15	SE24-010	ROLLER BUSHING	2
2	AE50-103	52mm SPH. BRG. - 1" BORE	2	16	SE50-004	ROLLER PIVOT BUSHING	2
3	FT50-007	WIRE LOCK PIN	1	17	UA27-185	TRAIL ROLLER SCRAPER	1
4	HW03010024G5ZPC	5/16 X 3/4 CARRIAGE BOLT	14	18	UA27-194	LOWER MOUNT	2
5	HW03010080G5ZPC	5/16 X 2 1/2 CARRIAGE BOLT	7	19	UA27-201	TOP LINK LOCK	1
6	HW03012032G5ZPC	3/8 X 1 CARRIAGE BOLT	4	20	UA50-028	1/2 ID X 2 OD X 3/16 WASHER	2
7	HW03016080G5ZPC	1/2 X 2 1/2 CARRIAGE BOLT	2	21	UA80-098	TRAIL ROLLER	1
8	HW22010G5ZPC	5/16 FLG. LK. NUT	21	22	UA80-099	TURNBUCKLE EYE; RH	1
9	HW22012G5ZPC	3/8 FLANGE LOCK NUT	4	23	UA80-100	TURNBUCKLE EYE; LH	1
10	HW24016GBZPC	1/2 STOVER LOCKNUT	2	24	UA80-101	ROLLER CROSS	1
11	HW27024096ZP	3/4 X 3 CLEVIS PIN	1	25	UA80-102	ATTACHMENT BRACKET	1
12	HW27024112ZP	3/4 X 3 1/2 CLEVIS PIN	1	26	UA80-103	ROLLER EXTENSION; LEFT	1
13	HW31024TAZP	3/4 SAE FLATWASHER	1	27	UA80-104	ROLLER EXTENSION; RIGHT	1
14	HW40004032ZP	1/8 X 1 COTTER PIN	2	28	UA81-021	TURNBUCKLE HANDLE	1

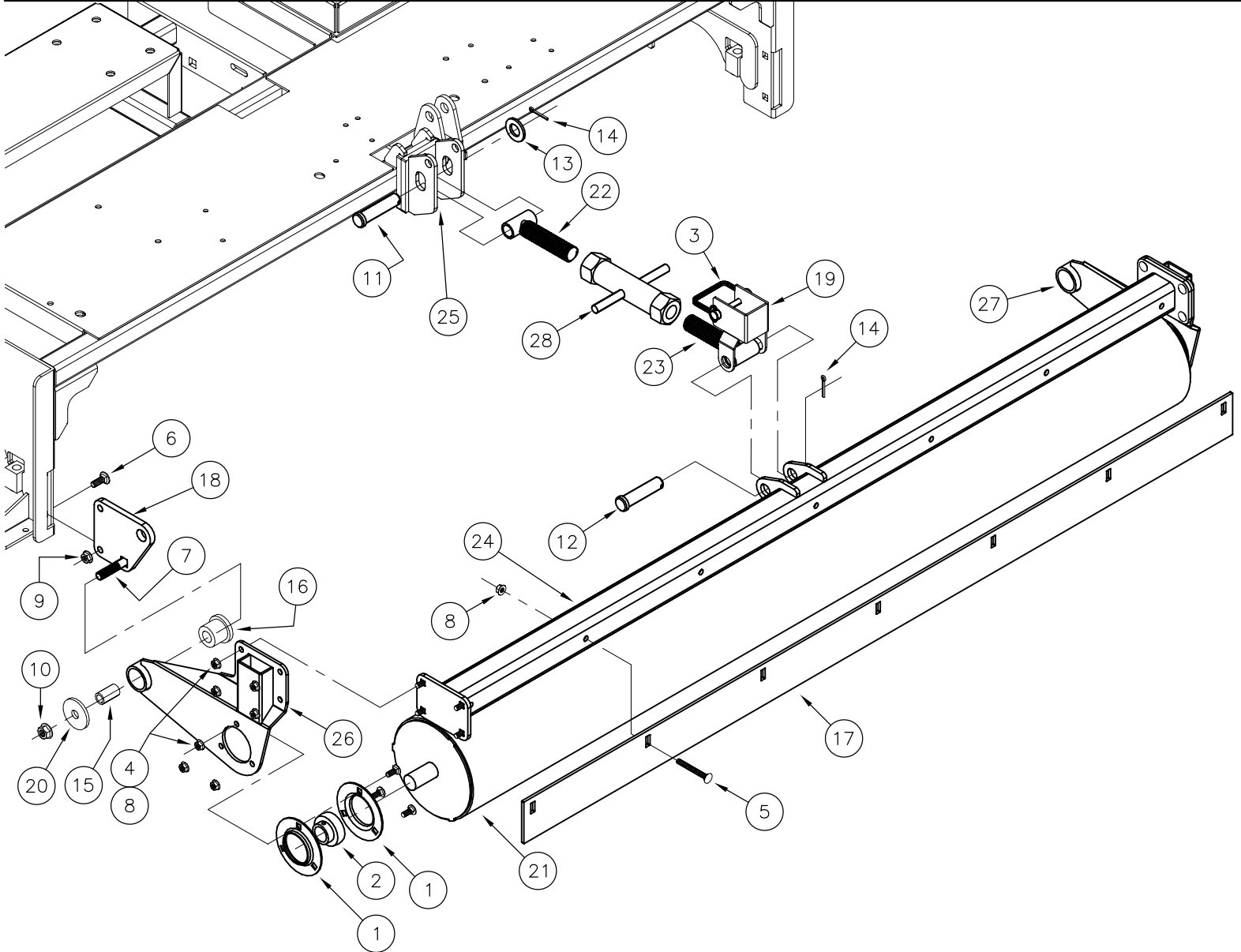

Brush Attachment (Optional)

ITEM	PART NO	DESCRIPTION	QTY	ITEM	PART NO	DESCRIPTION	QTY
1	AE50-156	BRIDGE PIN	1	13	HW30008TAZP	1/4 STD FLAT WASHER	18
2	HW01016032G5ZPC	1/2 X 1 HHCS	4	14	UA26-028	1/2 X 1 BARREL NUT	2
3	HW01016096G5ZPC	1/2 X 3 HHCS	1	15	UA50-131	1/2 X 3 BENT ARM PIN	1
4	HW01024096G5ZPC	3/4 X 3 HHCS	2	16	UA27-170	BRUSH LINK	1
5	HW03008024G5ZPC	1/4 X 3/4 CARRIAGE BOLT	18	17	UA27-182	BRUSH HOLDER	9
6	HW03008056G5ZPC	1/4 X 1 3/4 CARRIAGE BOLT	18	18	UA27-189	BRUSH EXT. ARM	2
7	HW22008G5ZPC	1/4 FLG. LK. NUT	18	19	UA27-254	BRUSH MAST	1
8	HW22012G5ZPC	3/8 FLANGE LOCK NUT	10	20	UA27-255	END CONNECTOR	2
9	HW22016G5ZPC	1/2 FLANGE LOCKNUT	4	21	UA50-047	GROOMING BRUSH	9
10	HW22024G5ZPC	3/4 FLANGE LOCK NUT	4	22	UA50-063	3/8 X 1 1/2 U-BOLT	5
11	HW24008GBZPC	1/4 STOVER LOCK NUT	18	23	UA80-109	CARRIER	1
12	HW24016GBZPC	1/2 STOVER LOCK NUT	1				

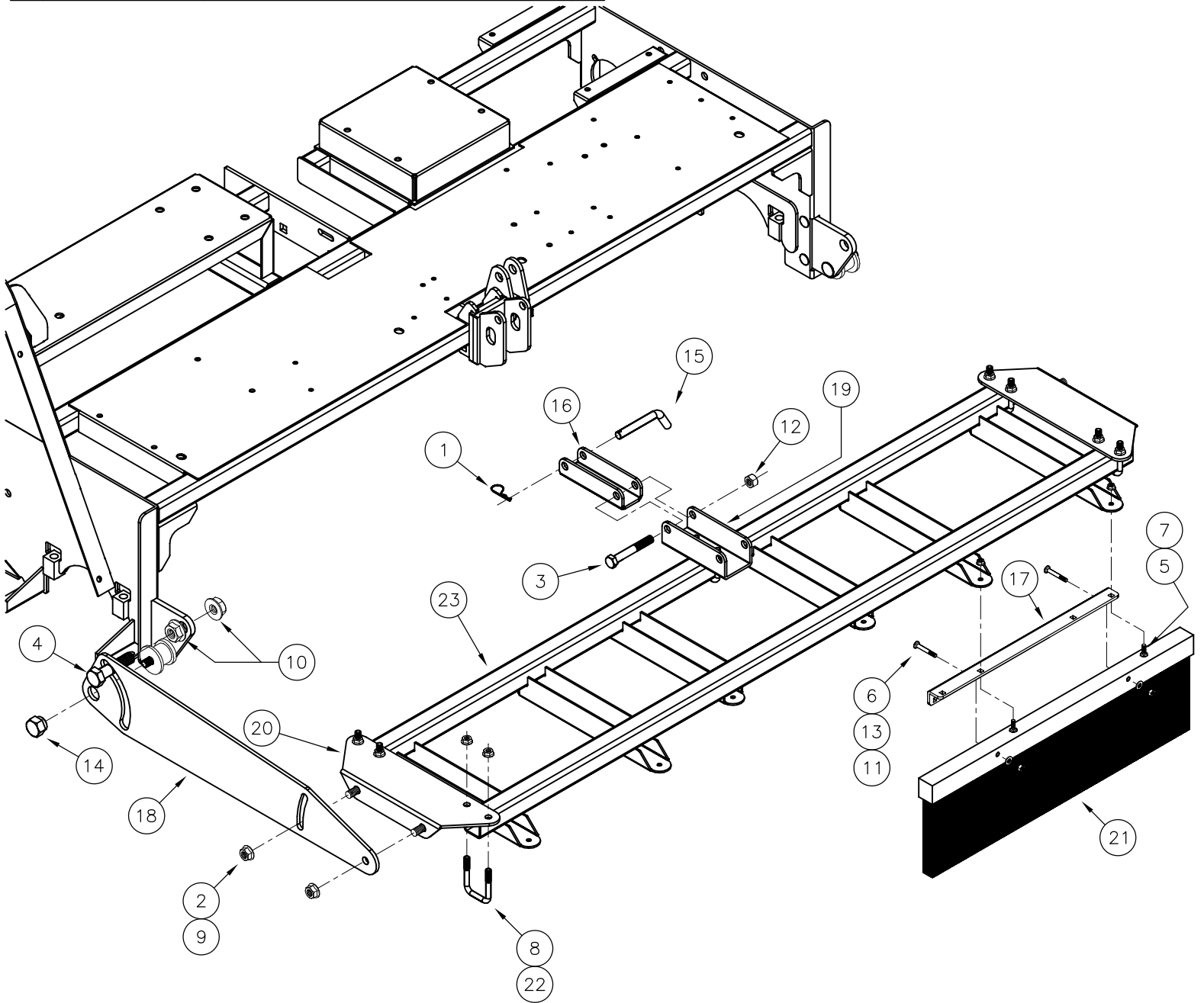

Aera-vator Shaft

ITEM	PART NO	DESCRIPTION	QTY	ITEM	PART NO	DESCRIPTION	QTY
1	AE24-011	LONG SPACER 7 1/4	4	12	HW22012G5ZPC	3/8 FLANGE LOCKNUT	12
2	AE24-027	DRIVE END SPACER 3 13/16	2	13	HW25036G5ZPF	1 1/8 - 12 JAM NUT FINE	2
3	AE26-021	ROTOR SHAFT - 60	1	14	HW32020G8ZP	5/8" LOCKWASHER G8	144
4	AE50-005	EXTERNAL ROTOR SEAL	12	15	HW32036G5ZP	1 1/8 LOCKWASHER	2
5	AE50-029	3" INTERNAL SNAP RING	12	16	SE80-015	ROTOR ONLY	6
6	AE50-058	TINE - 5/8" NF	144	17	SE81-002	ROTOR ASS'Y W/O TINES	6
7	AE50-090	1 1/8 HEX BORE BEARING	3	18	UA24-004	OUTER ROTOR SPACER 3 7/32	1
8	AE50-094	72mm X 4 HOLE FLANGE	6	19	UA24-013	END SPACER - UN60	1
9	AE60T-003	15/16" EXTRA DEEP SOCKET	1	20	UA50-033	4B 4.65 X 1 1/8 HEX BORE SHEAVE	1
10	HW03012032G5ZPC	3/8 X 1 CARRIAGE BOLT	12	21	UA80-006	ROTOR SHAFT ADAPTOR PLATE	3
11	HW20020G5PLF	5/8" NF HEX NUT G5 PLAIN	144	22	UA81-128	UA 5° SJA ASSY	6

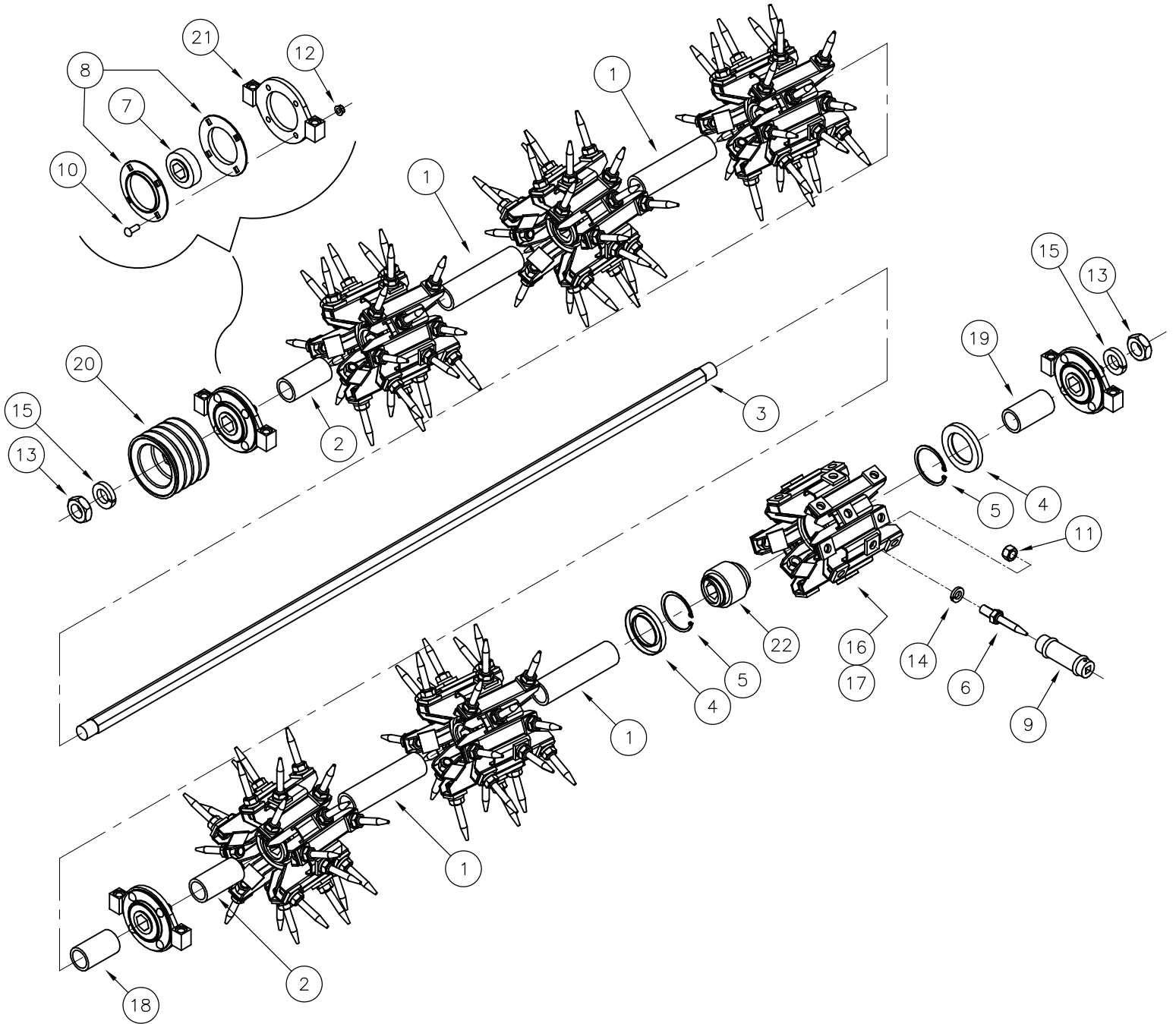

Multi-tine Shaft

ITEM	PART NO	DESCRIPTION	QTY	ITEM	PART NO	DESCRIPTION	QTY
1	AE24-011	LONG SPACER 7 1/4	4	12	HW03012032G5ZPC	3/8 X 1 CARRIAGE BOLT	12
2	AE24-027	DRIVE END SPACER 3 13/16	2	13	HW12012032G5PC	3/8 X 1 TORX PLUS BUT. HD. CAPSW.	108
3	AE26-021	ROTOR SHAFT - 60	1	14	HW22012G5ZPC	3/8 FLANGE LOCKNUT	12
4	AE50-005	EXTERNAL ROTOR SEAL	12	15	HW25036G5ZPF	1 1/8 - 12 JAM NUT FINE	2
5	AE50-029	3" INTERNAL SNAP RING	12	16	HW32036G5ZP	1 1/8 LOCKWASHER	2
6	AE50-090	1 1/8 HEX BORE BEARING	3	17	UA24-004	OUTER ROTOR SPACER - 3 7/32	1
7	AE50-094	72mm X 4 HOLE FLANGE	6	18	UA24-013	END SPACER - UN60	1
8	FT50-006	J-TYPE RETAINER NUT	108	19	UA50-033	4B 4.65 X 1 1/8 HEX BORE SHEAVE	1
9	FT50-009	TORX PLUS BIT	1	20	UA80-006	ROTOR SHAFT ADAPTOR PLATE	3
10	FT80-002	ROTOR ONLY	6	21	UA80-080	FLAT TINE SHELL, 2" TINES	36
11	FT81-001	ROTOR ASSY W/O SHELLS	6	22	UA81-129	UA 2° SJA ASS'Y	6

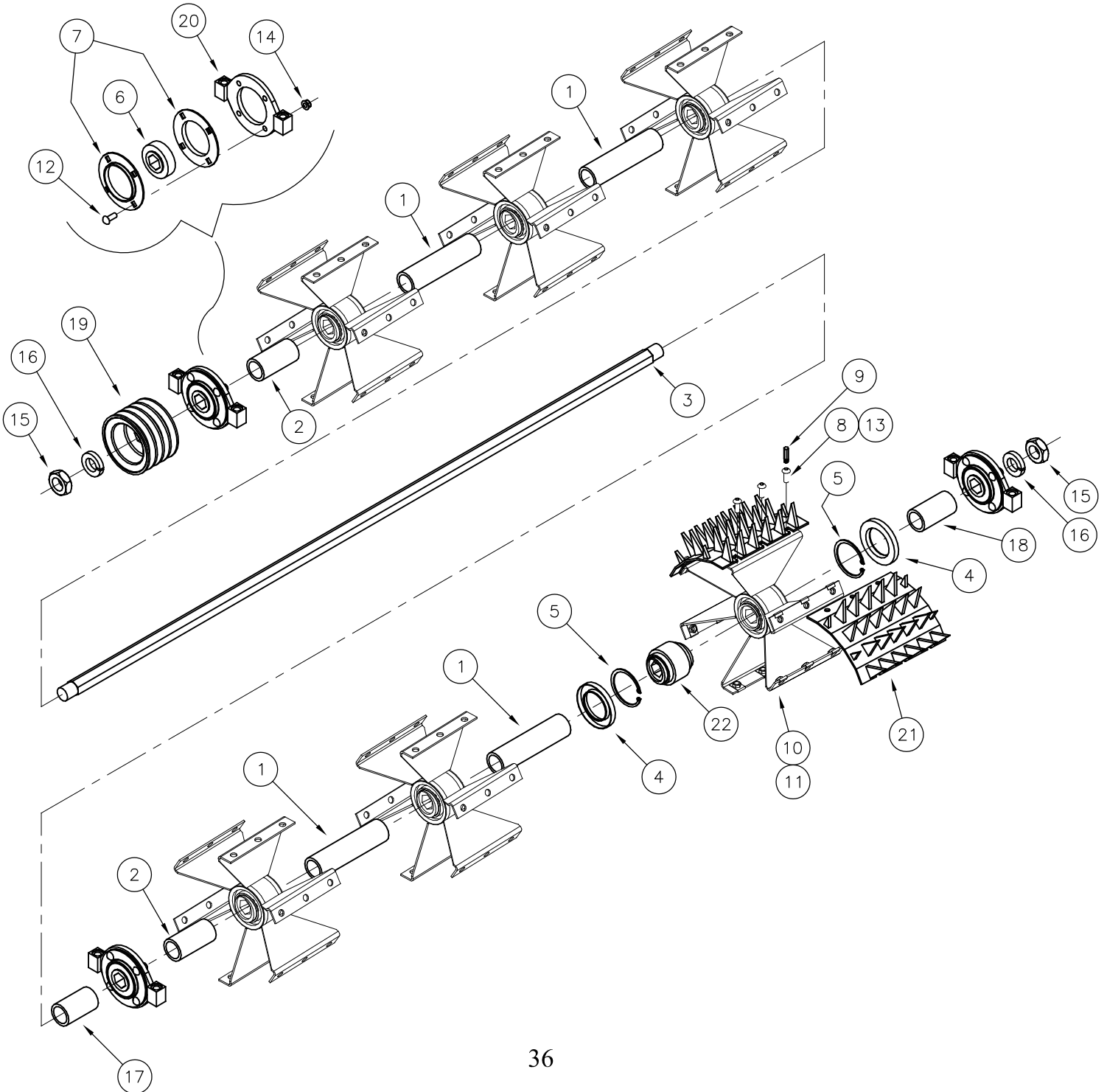

Aera-slicer Shaft

ITEM	PART NO	DESCRIPTION	QTY	ITEM	PART NO	DESCRIPTION	QTY
1	AE24-028	3 9/16 CENTER SPACER	10	11	AS81-001	SLICER BRG/ADAPTER ASS'Y	24
2	AE26-021	ROTOR SHAFT - 60	1	12	AS81-002	SLICER HUB COMPLETE W/O BLADES	12
3	AE50-015	INT. SNAP RING - 80mm	24	13	HW03012032G5ZPC	3/8 X 1 CARRIAGE BOLT	12
4	AE50-090	1 1/8 HEX BORE BEARING	3	14	HW06012024G5ZPC	3/8 X 3/4 HEX FLG. LOCK SCREW	120
5	AE50-094	72mm X 4 HOLE FLANGE	6	15	HW22012G5ZPC	3/8 FLANGE LOCKNUT	132
6	AS24-002	1 11/16 PULLEY SPACER - AS	2	16	HW25036G5ZPF	1 1/8 - 12 JAM NUT FINE	2
7	AS24-003	15/16" CENTER BRG. SPACER - AS	1	17	HW32036G5ZP	1 1/8 LOCKWASHER	2
8	AS24-004	1 3/16 FREE END SPACER - AS	1	18	UA50-033	4B 4.65 X 1 1/8 HEX BORE SLEEVE	1
9	AS50-001	5" BLADE - AS	60	19	UA80-006	ROTOR SHAFT ADAPTOR PLATE	3
10	AS80-001	SLICER HUB	12				

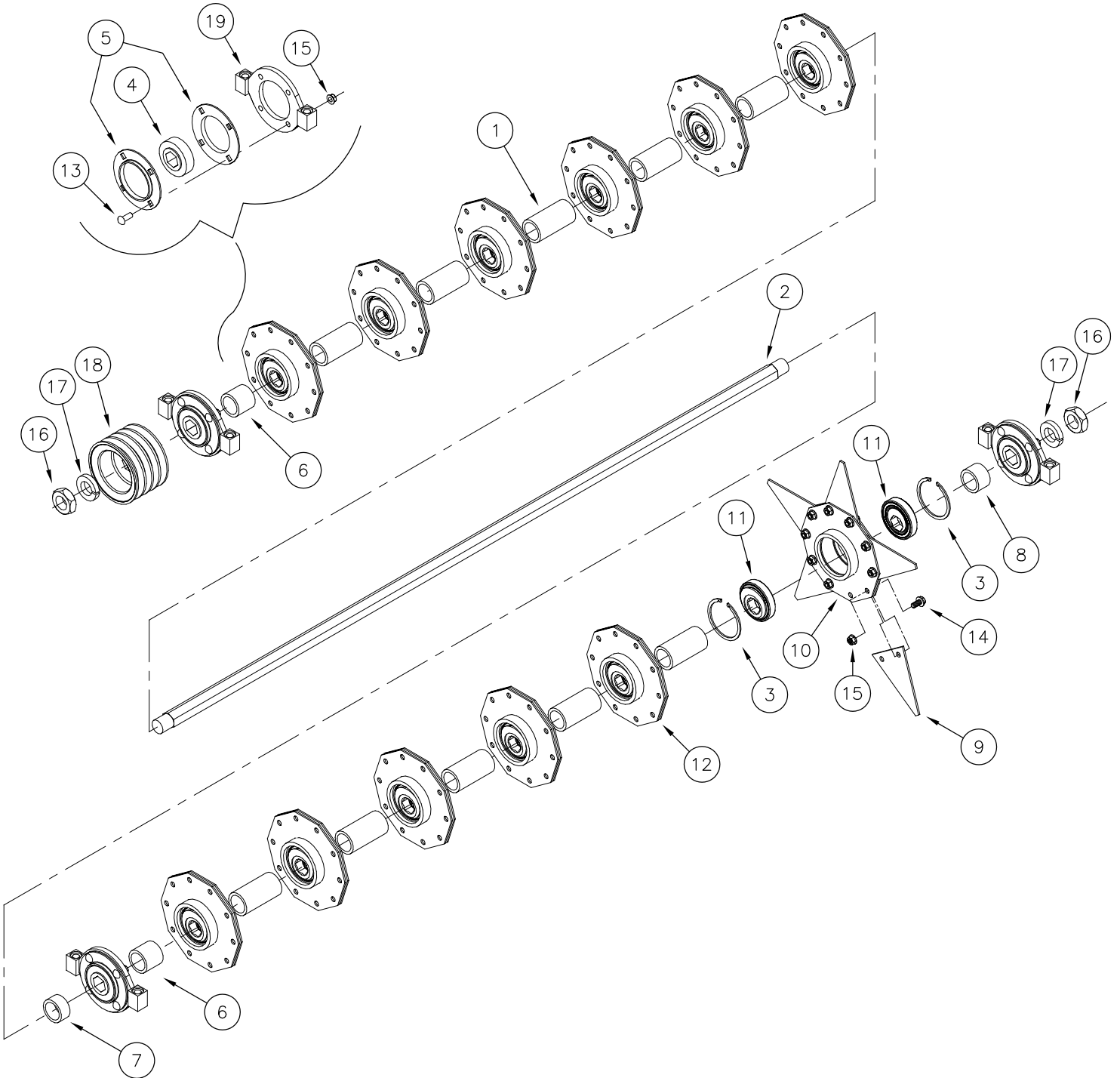

Multi-spike Shaft

ITEM	PART NO	DESCRIPTION	QTY	ITEM	PART NO	DESCRIPTION	QTY
1	AE50-094	72mm X 4 HOLE FLANGE	4	9	UA27-234	DRUM CAP	2
2	AG50-013	1 3/8 BORE BEARING	2	10	UA27-236	SPIKER SCRAPER	1
3	HW01012112G5ZPC	3/8 X 3 1/2 HHCS	2	11	UA27-239	SCRAPER HOLDER	1
4	HW03012024G5ZPC	3/8 X 3/4 CARRIAGE BOLT	9	12	UA27-262	OUTER SPIKER SCRAPER	2
5	HW03012032G5ZPC	3/8 X 1 CARRIAGE BOLT	8	13	UA50-129	SPIKE COLLAR	35
6	HW06010024G5ZPC	5/16 X 3/4 FLANGE LOCK SCREW	8	14	UA80-115	ADAPTOR PLATE - MS	2
7	HW22012G5ZPC	3/8 FLANGE LOCKNUT	19	15	UA80-132	SPIKER DRUM - 60	1
8	UA24-070	SCRAPER SPACER	2				

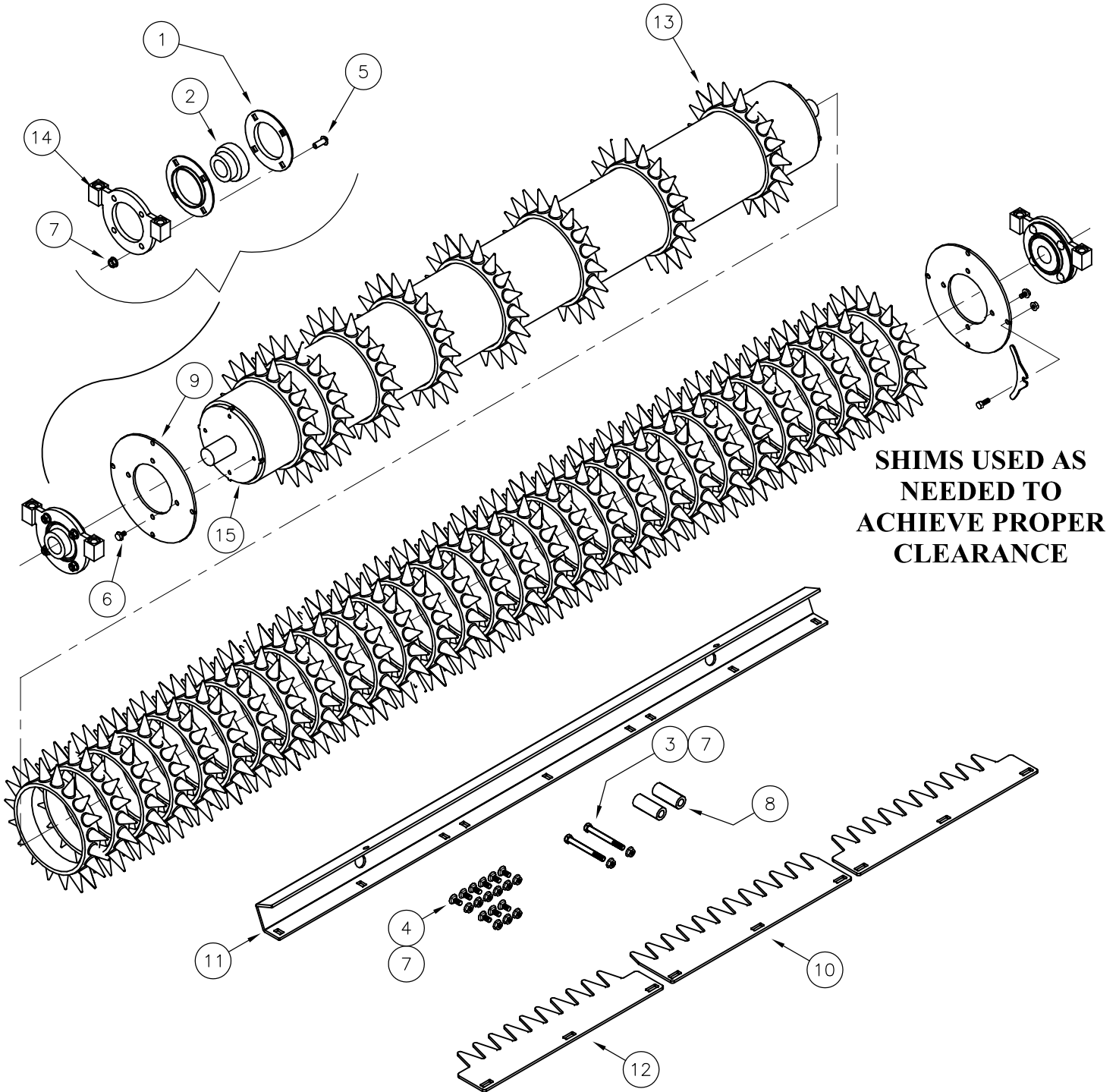

Coring Shaft

ITEM	PART NO	DESCRIPTION	QTY	ITEM	PART NO	DESCRIPTION	QTY
1	HW01020040G2ZPC	5/8 X 1 1/4 HEX CAPSCREW	2	9	UA80-125	CORE SHAFT END MNT PLT. LEFT	1
2	HW24012GBZPC	3/8 STOVER LOCK NUT	192	10	UA80-126	CORE SHAFT END MNT PLT. RIGHT	1
3	HW32020G5ZP	5/8 LOCKWASHER	2	11	UA80-127	CORE SHAFT INTERM. SUPPORT, LEFT	1
4	UA26-035	CORING SHAFT-60	1	12	UA80-128	CENTERED CORE HUB	8
5	UA50-123	SPOON-3/4 CLOSED	96	13	UA80-129	OFF CENTERED CORE HUB	4
6	UA50-124	U-BOLT CORE TINE	96	14	UA50-130	1 1/4 X 1 1/2 X 2 SLEEVE BEARING	1
7	UA50-125	CLAMP-BRACE, CORE TINE	192	15	HW5000845F	45° GREASE ZERK, 1/4-28 THREAD	12
8	UA50-126	FLANGE BEARING, 1-1/4 x 1-1/2	24				

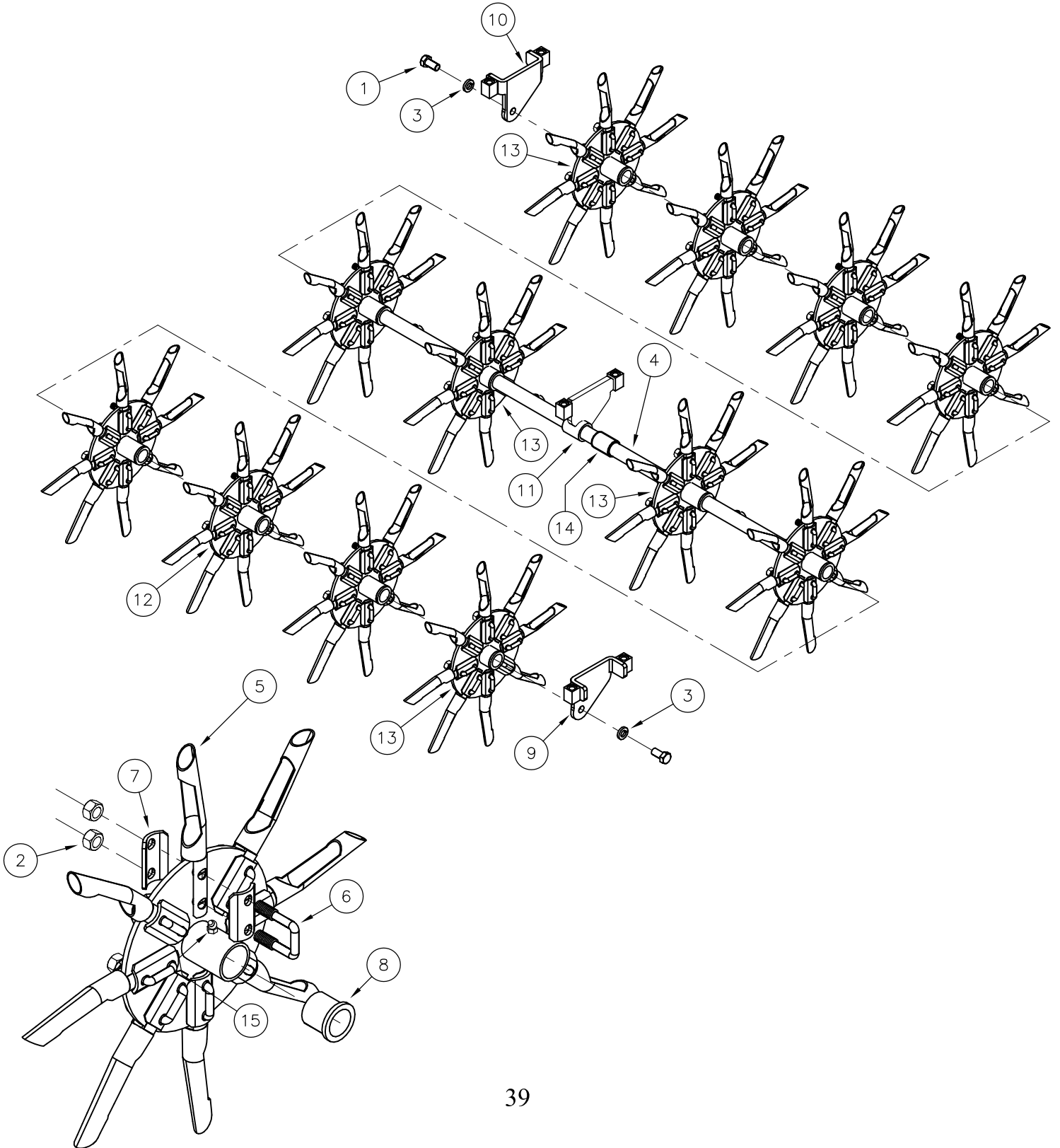

Lighting Group

ITEM	PART NO	DESCRIPTION	QTY	ITEM	PART NO	DESCRIPTION	QTY
1	HW01010024G5ZPC	5/16 X 3/4 HHCS	4	10	UA27-267	TAIL LIGHT POST, LH	1
2	HW04008024ZPC	1/4 X 3/4 HEX HEAD SELF TRD	24	11	UA27-268	TAIL LIGHT POST, RH	1
3	HW06008024G5ZPC	1/4 X 3/4 HEX FLG LOCK SCREW	2	12	UA27-269	POST BRACE	2
4	HW16#10024G5ZPC	#10 X 3/4 CROSS HEAD SCREW	3	13	UA50-086	CABLE LOOP - 3/8	2
5	HW22008G5ZPC	1/4 FLANGE LOCK NUT	2	14	UA50-140	TAIL LIGHT, 6" OVAL LED	2
6	HW22010G5ZPC	5/16 FLANGE LOCK NUT	4	15	UA50-141	GROMMET, 6" OVAL TAILLIGHT	2
7	HW23#10G5ZPC	#10 NYLON LOCK NUT	3	16	UA50-143	LICENSE PLATE LIGHT	1
8	UA27-265	TAIL LIGHT COVER, LH	1				
9	UA27-266	TAIL LIGHT COVER, RH	1				

LEFT TAIL LIGHT ASSM.

RIGHT TAIL LIGHT ASSM.

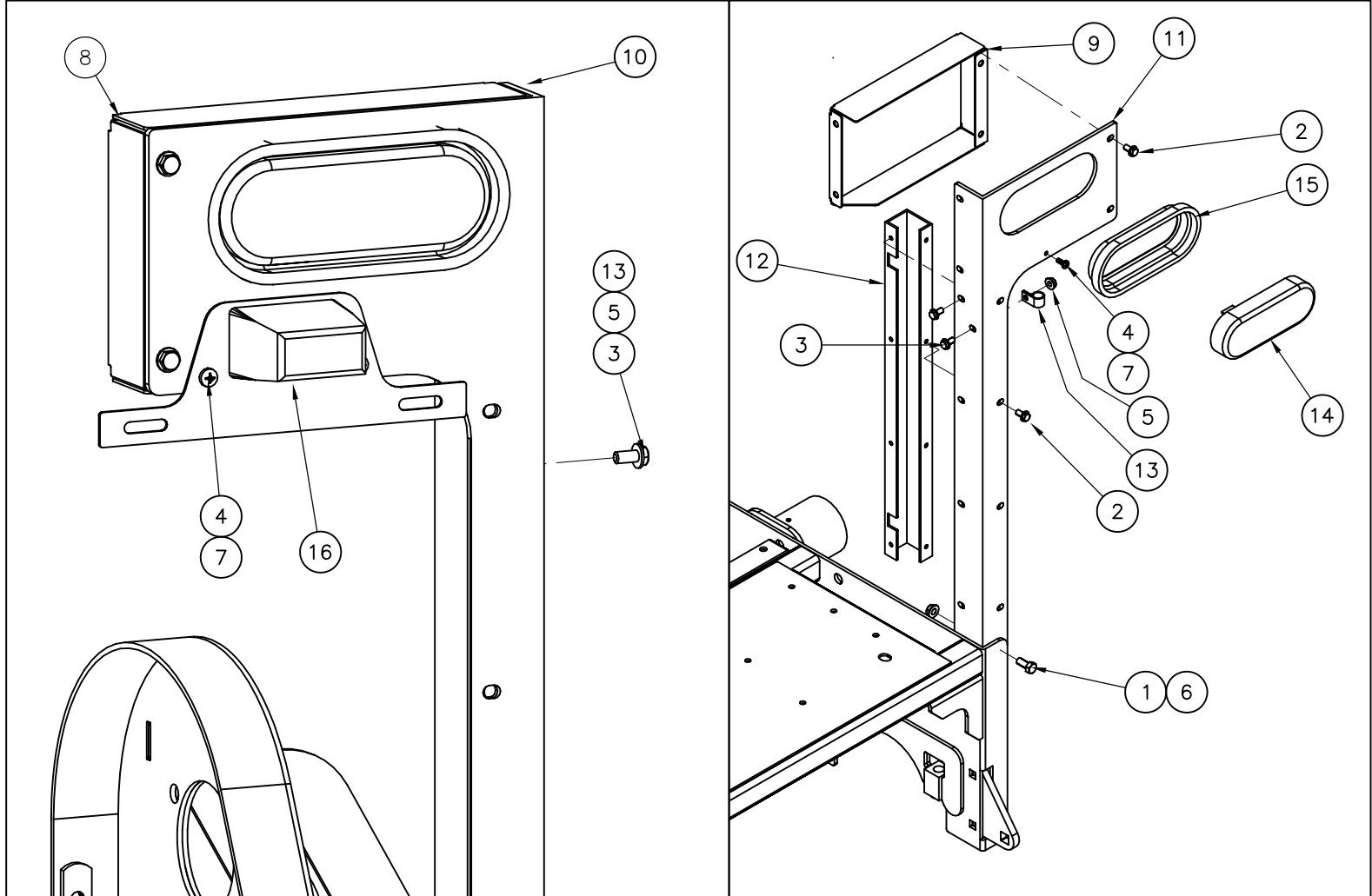

Troubleshooting

Important: It is essential that all operator safety mechanisms be connected and in proper condition prior to use.

When a problem occurs, do not overlook the simple causes. For example: starting problems could be caused by an empty fuel tank.

The following table lists some of the common cause of trouble. Do not attempt to service or repair major items or any items that call for special timing of adjustments procedures (such as valves, governor, etc.). Have this work done by your First Products Dealer service technician.

NOTE: When disconnecting electrical connectors DO NOT pull on the wires to separate the connectors.

Problem	Possible Cause	Corrective Action
Starter does not crank	<ol style="list-style-type: none"> 1. Electric clutch turned on. 2. Battery does not have full charge. 3. Electrical connections are corroded, loose, or faulty. 4. Fuse Blown. 5. Relay or switch is defective. 	<ol style="list-style-type: none"> 1. Turn clutch off. 2. Charge battery. 3. Check the electrical connections for good contact. Clean connector terminals thoroughly with electrical contact cleaner, apply dielectric grease and reconnect. 4. Replace the blown fuse. 5. Contact an Authorized Service Dealer.
Engine will not start, starts hard, or fails to keep running.	<ol style="list-style-type: none"> 1. Fuel tank is empty 2. Oil level in the crankcase is low. 3. Throttle and choke are not in the correct position. 4. Dirt in fuel filter. 5. Dirt, water, or stale fuel is in fuel system. 6. Air filter is dirty. 	<ol style="list-style-type: none"> 1. Fill the fuel tank. 2. Add oil to crankcase. 3. Be sure the throttle control is midway between the "SLOW" and "FAST" positions, and the choke is in the "ON" position for a cold engine or the "OFF" position for a warm engine. 4. Replace the fuel filter. 5. Contact an Authorized Service Dealer. 6. Clean or replace the air filter.

	<ol style="list-style-type: none"> 7. Electrical connections are corroded, loose, or faulty. 8. Relay or switch is defective. 9. Faulty spark plug. 10. Spark plug wire is not connected. 	<ol style="list-style-type: none"> 7. Check the electrical connections for good contact. Clean connector terminals thoroughly with electrical contact cleaner, apply dielectric grease and reconnect. 8. Contact an Authorized Service Dealer. 9. Clean, adjust or replace spark plug.. 10. Check the spark plug wire connection.
Engine loses power	<ol style="list-style-type: none"> 1. Engine load is excessive. 2. Air Cleaner is dirty. 3. Oil in crankcase is low. 4. Cooling fins and air passage for the engine are plugged. 5. Vent in fuel cap is clogged. 6. Dirt in fuel filter. 7. Dirt, water, or stale fuel in the fuel system. 	<ol style="list-style-type: none"> 1. Reduce the ground speed. 2. Clean or replace the air cleaner. 3. Add oil to the crankcase. 4. Remove the obstructions from the cooling fins and air passages. 5. Clean or replace the fuel cap. 6. Replace the fuel filter. 7. Contact an Authorized Service Dealer.
Engine overheats	<ol style="list-style-type: none"> 1. Engine load is excessive. 2. Oil level in the crankcase is low. 3. Cooling fins and air passages for the engine are clogged 	<ol style="list-style-type: none"> 1. Reduce ground speed. 2. Add oil to the crankcase. 3. Remove the obstructions from the cooling fins and air passages.
Rotor Shaft does not operate	<ol style="list-style-type: none"> 1. Rotor switch is not in the “ON” position. 2. Relay or switch is defective. 3. Electrical connections are corroded, loose, or faulty. 4. Drive belt is broken or worn. 5. Broken or missing idler spring. 	<ol style="list-style-type: none"> 1. Switch to “ON” position. 2. Contact an Authorized Service Dealer. 3. Check the electrical connections for good contact. Clean connector terminals thoroughly with electrical contact cleaner, apply dielectric grease and reconnect. 4. Change the Belt. 5. Replace the spring.

Machine Electrical Wiring Diagram

View from
back of socket

UA50-083 SOCKET WIRE ASS'Y

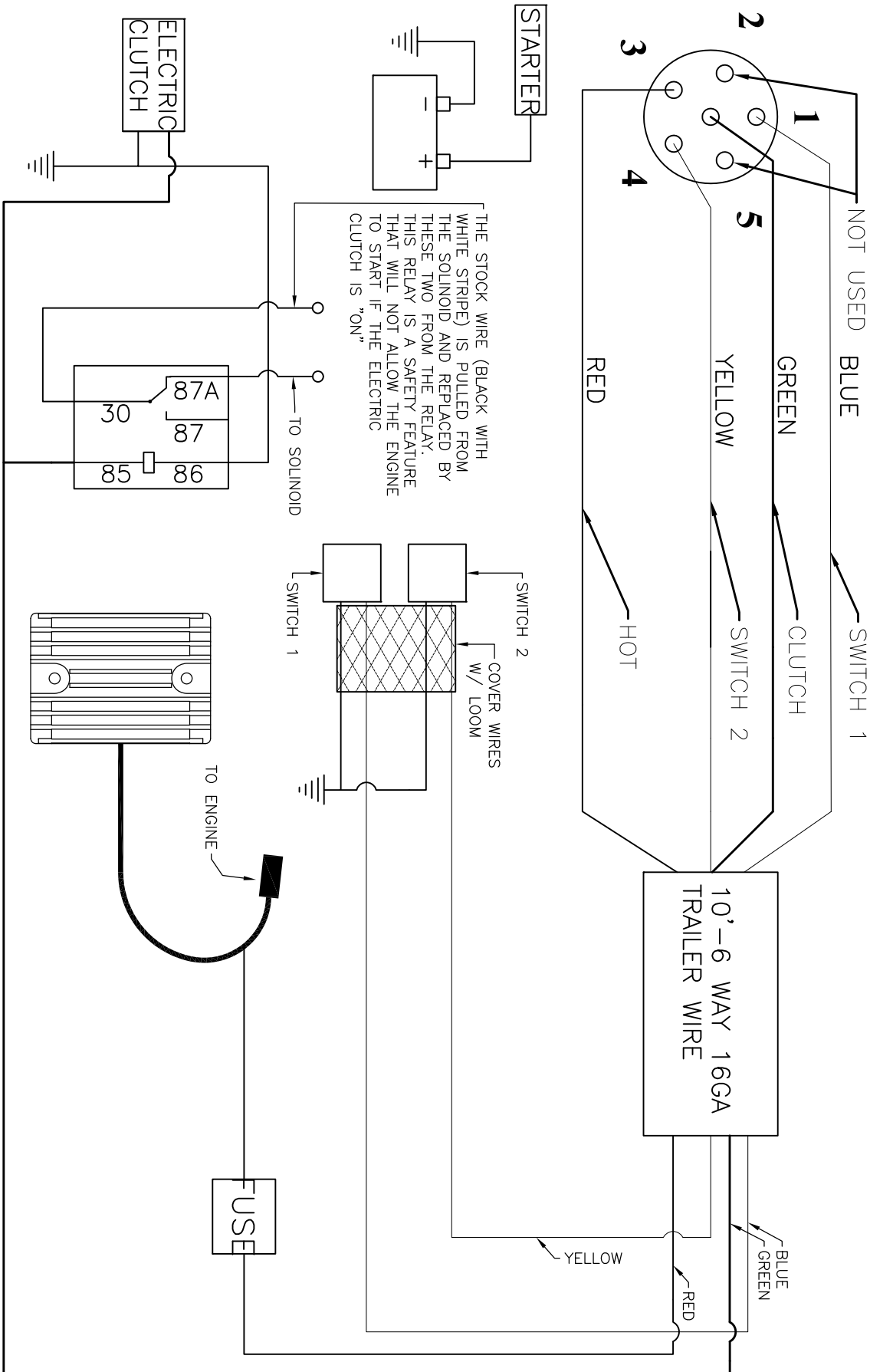

Control Electrical Wiring Diagram

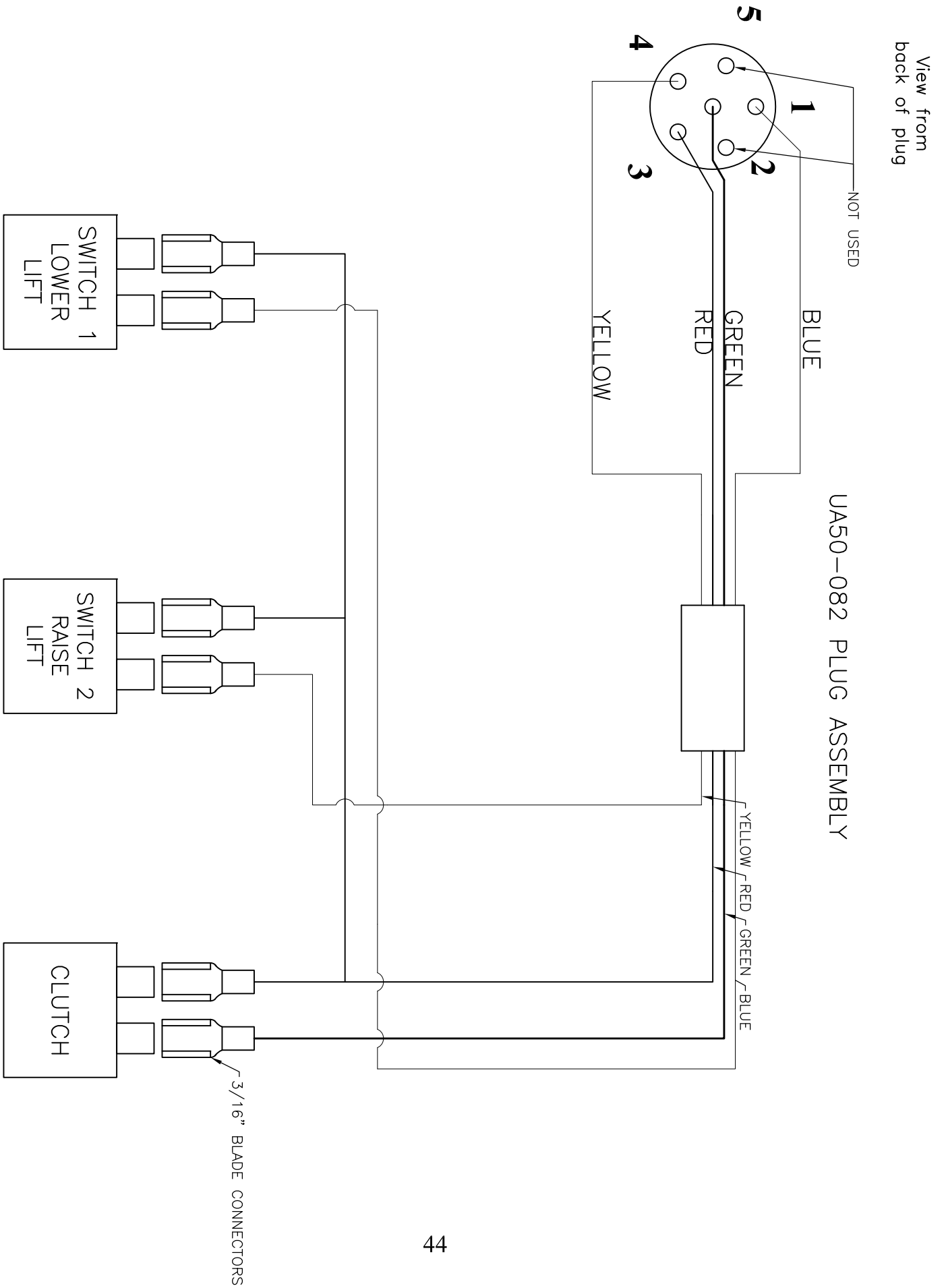

Lighting Electrical Wiring Diagram

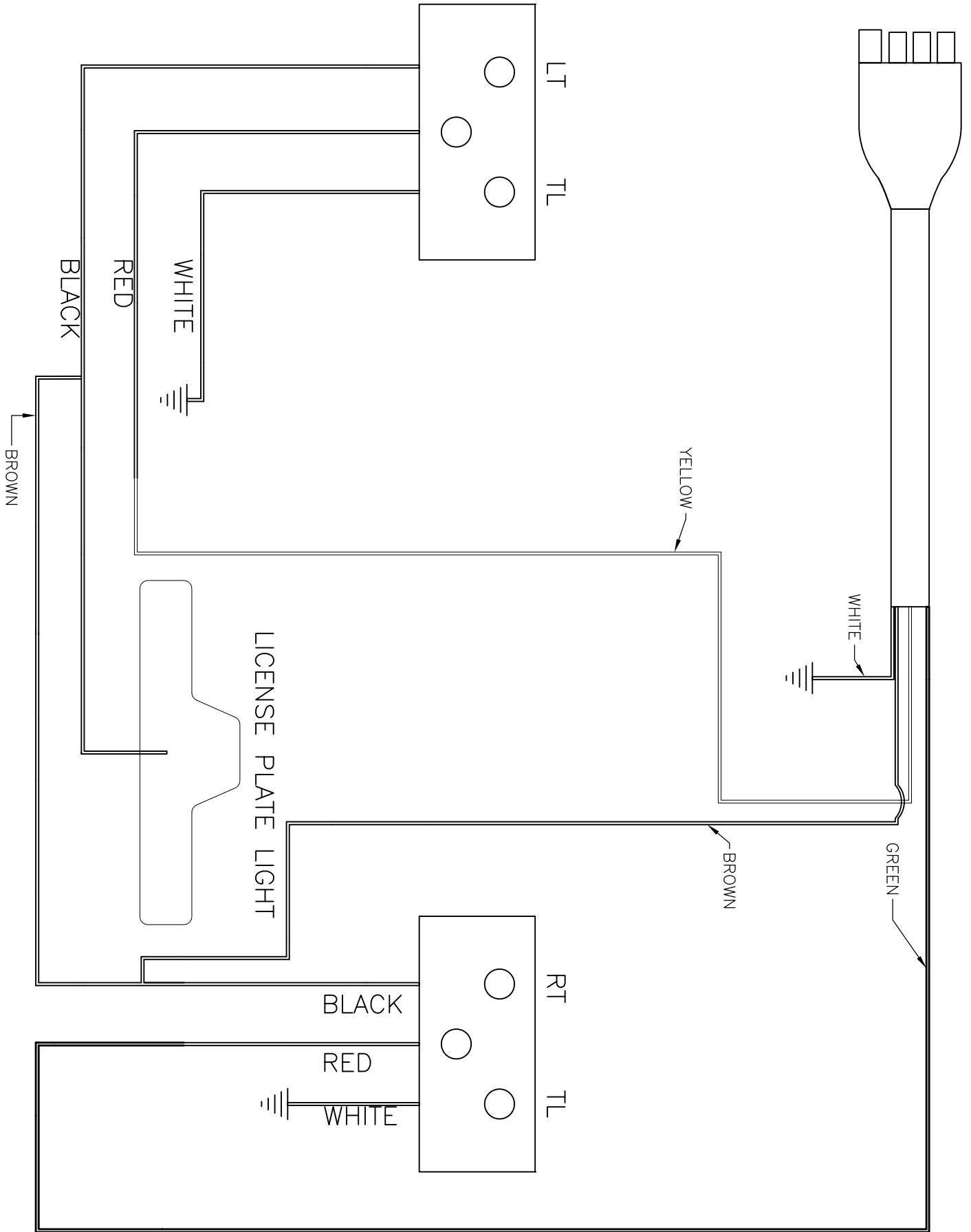

Hydraulics Schematic

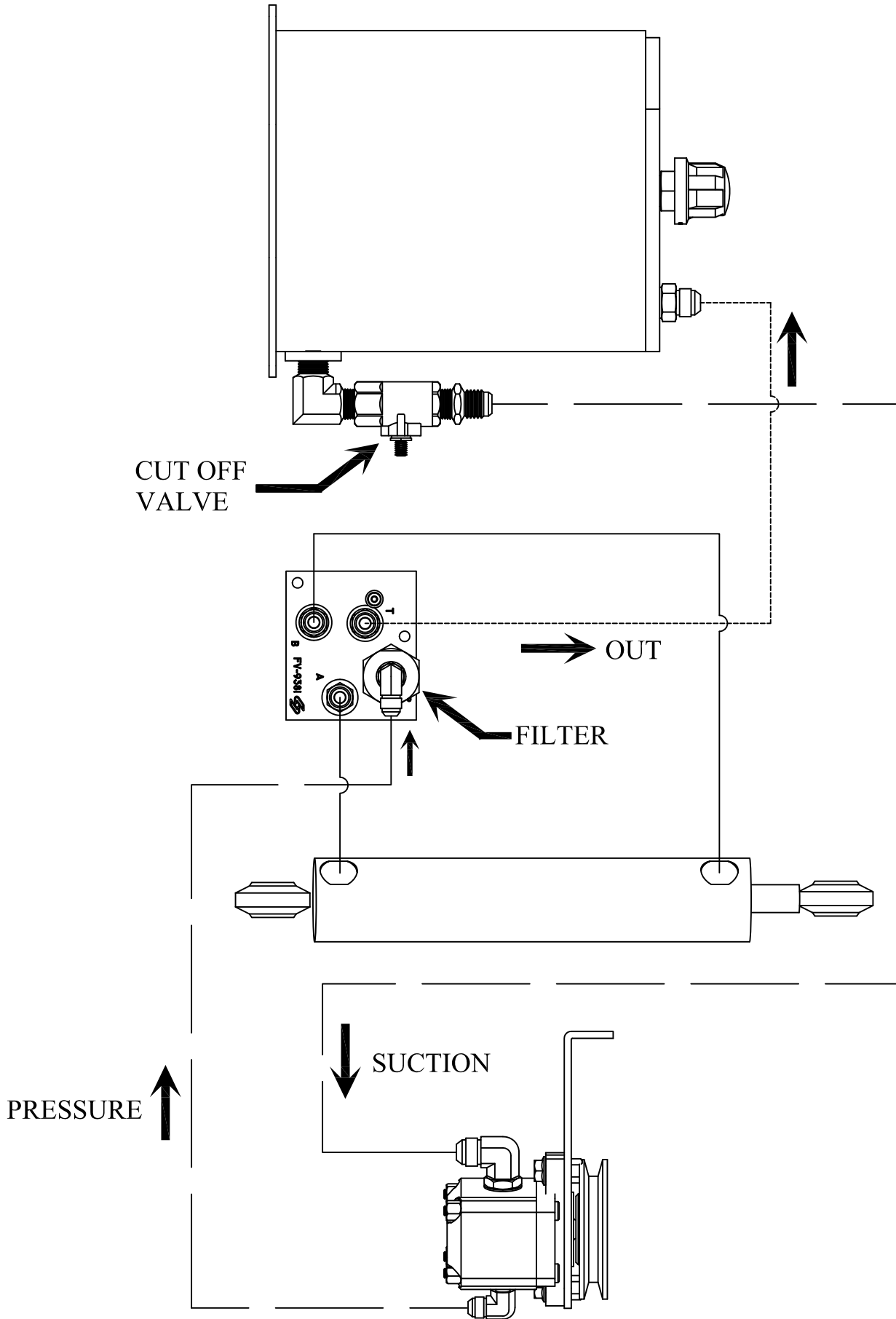

Notes:

Notes:

Notes:

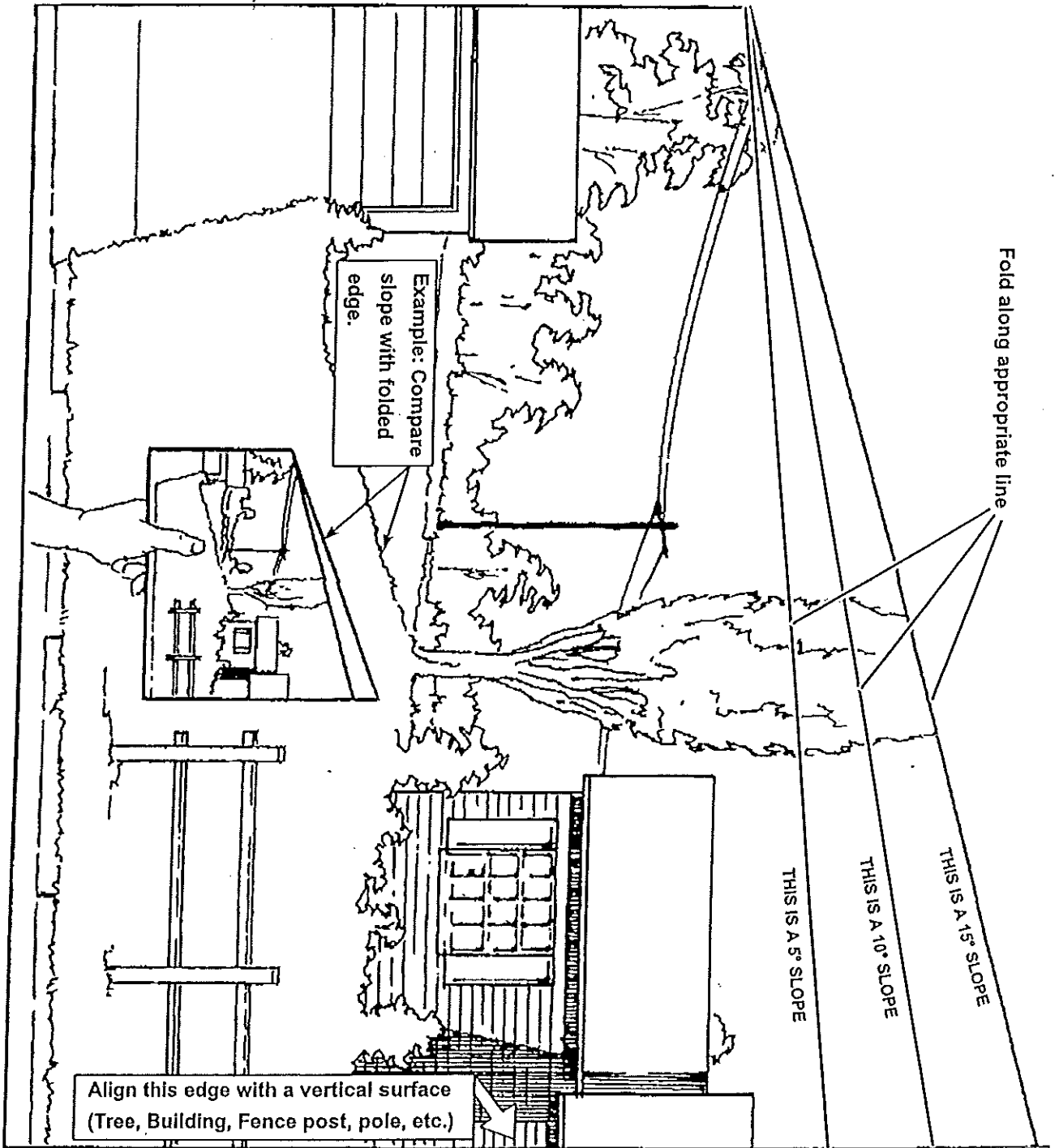

Fold along appropriate line

Example: Compare slope with folded edge.

Align this edge with a vertical surface (Tree, Building, Fence post, pole, etc.)

THIS IS A 5° SLOPE

THIS IS A 10° SLOPE

THIS IS A 15° SLOPE

AERA-VATOR & ATTACHMENTS SPECIFICATIONS**AERA-VATOR****60" WIDTH**

WEIGHT (<i>less shaft and attachments</i>)		1041 LBS
WORKING WIDTH		60"
CENTER DRIVE GEARBOX		1:3 RT. ANGLE
END DRIVE		(4) "BX" 46 BELTS (left end)
TINE VIBRATION FREQUENCY		@ 3600 ENGINE RPM = 800 Cycles/Min
ENGINE		28 HP HORIZONTAL SHAFT
FINISH		Black Acrylic w Grey Trim

ROLLER**60" WIDTH**

WEIGHT *		(Approx.) 225 LBS
DIAMETER		8 5/8"

AERA-VATOR SHAFT**60" WIDTH**

WEIGHT *		236 LBS
VIBRATING DEPTH		3 3/4 inches
SIDE-TO-SIDE TINE TRAVEL		1 3/8 inches
AERATION DENSITY		9 Holes per Sq. Ft
TINES		9/16 x 3 3/4 Forged & Hardened (144)
ROTOR BEARINGS		Double Sealed Tapered Roller

MULTI-TINE SHAFT**60" WIDTH**

WEIGHT *		245 LBS
SIDE-TO-SIDE TINE TRAVEL		1/2 inches
VIBRATING DEPTH		1 3/8 inches
AERATION DENSITY		55 Holes per Sq. Ft
SHELLS (6 per ROTOR)		36
ROTOR BEARINGS		Double Sealed Tapered Roller

SLICER SHAFT**60" WIDTH**

WEIGHT *		155 LBS
VIBRATING DEPTH		4 1/4 inches Full Depth
AERATION DENSITY		5-6 Holes per Sq. Ft
BLADE SPACING		5 INCHES
BLADES		5'' long, 10 Ga Hardened Spring Steel (60 ea)
BEARINGS		50 mm Ball Bearing

ATHLETIC FIELD/SYNTHETIC BRUSH**60" WIDTH**

WEIGHT *		95 LBS
ADJUSTABLE WORKING WIDTH		60" TO 72 1/2"
BRUSH ATTACHMENT		CENTER ROW 0 TO 30 DEGREES
BRUSH		(9) 24" WIDE X 5" LONG X 1 1/2" THICK
MATERIAL		POLYPROPYLENE

*Add weight to AERA-vator when selected